

**GENESIS®**

The Promise of Performance.

# LXP® 800 Logix Processor

## PARTS MANUAL



## CONTACT INFORMATION

### Genesis Attachments

1000 Genesis Drive  
Superior, WI 54880 USA

Toll Free: 888-SHEAR-IT  
(888-743-2748)

Phone: 715.395.5252

E-mail:  
info@genesisattachments.com

### Europe/Africa/Middle East Genesis GmbH

Teramostrasse 23  
87700 Memmingen, Germany

Phone: +49 83 31 9 25 98 0  
Fax: +49 83 31 9 25 98 80  
genesis-europe.com

E-mail:  
info@genesis-europe.com

### Asia Pacific Representative Office

24 Upper Serangoon View #12-28  
Singapore 534205

Phone: +65 9673 9730

E-mail:  
tchoo@genesisattachments.com

### Central America & Colombia

Cra 13A #89-38 / Ofi 613  
Bogota, Colombia

Phone: +57 1 610 8160 / 795 8747

E-mail:  
contact@themsagroup.com

View and download all manuals: [genesisattachments.com/manuals](http://genesisattachments.com/manuals)  
Patents: [genesisattachments.com/products/patents](http://genesisattachments.com/products/patents)

# TABLE OF CONTENTS

<b>CONTACT INFORMATION</b>	<b>2</b>
<b>THIRD-MEMBER MOUNT UPPER HEAD</b>	<b>4</b>
<b>SECOND-MEMBER MOUNT UPPER HEAD</b>	<b>5</b>
<b>MULTI-PROCESSOR BODY</b>	<b>6</b>
<b>SHEAR JAW SET PIVOT GROUP</b>	<b>8</b>
<b>CONCRETE CRACKER JAW SET PIVOT GROUP</b>	<b>10</b>
<b>CONCRETE PULVERIZER JAW SET PIVOT GROUP</b>	<b>12</b>
<b>HYDRAULICS</b>	<b>14</b>
<b>SHEAR JAW SET</b>	<b>16</b>
<b>CONCRETE CRACKER JAW SET</b>	<b>18</b>
<b>CONCRETE PULVERIZER JAW SET - BOLT-IN TEETH</b>	<b>20</b>
<b>ROTATION DRIVE SYSTEM</b>	<b>22</b>
<b>ELECTRICAL</b>	<b>24</b>
<b>BOLT TORQUE SPECIFICATIONS</b>	<b>25</b>
<b>THREAD TREATMENT DIAGRAM</b>	<b>26</b>
Mobile Shears	26
Processors	27
<b>PROCEDURES</b>	<b>28</b>
Cleaning	28
Threadlocker	28
Anti-Seize	29
No Thread Treatment	29
<b>BOLT TORQUE SPECIFICATIONS</b>	<b>30</b>
Dry Torque Values	30
Wet Torque Values	30
<b>O-RING BOSS &amp; FLAT FACE O-RING TORQUE SPECIFICATIONS</b>	<b>31</b>
<b>BOLT DRIVE SPECIFICATIONS</b>	<b>32</b>
<b>TOOL LIST</b>	<b>33</b>
<b>WARRANTY</b>	<b>34</b>
Claim Procedure	34
Blade Warranty	34
<b>PARTS ORDER POLICY AND PROCEDURE</b>	<b>35</b>
Parts Orders Should Include	35
Placing Orders	35
Part Numbers	35
Shipping	35
Invoices	35
Returns	35
Warranty Returns	35
<b>PARTS ORDER FORM</b>	<b>36</b>
<b>INDEX</b>	<b>37</b>
<b>CONTACT INFORMATION</b>	<b>39</b>

# THIRD-MEMBER MOUNT UPPER HEAD

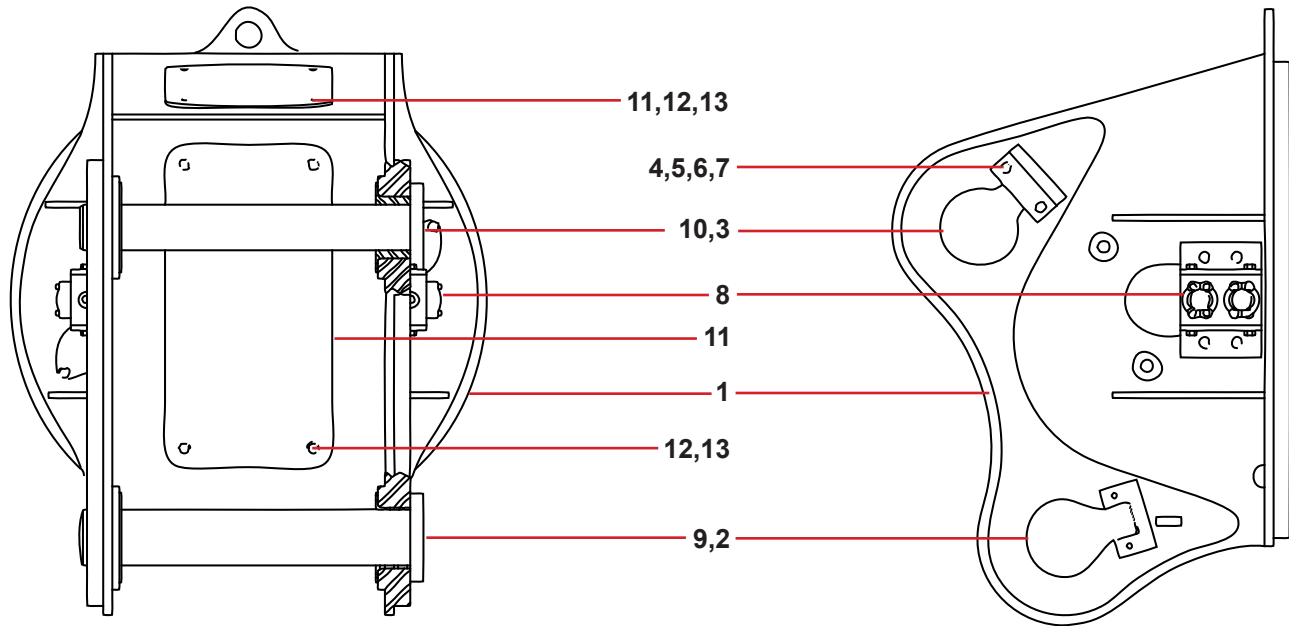

Item	Description
1	Upper Head
2	Stick Pin
3	Spacer Sleeves, where used
4	Pin Keeper
5	Strap
6	Hex Head Capscrew Bolt
7	Lock Washer
8	Port Block Assembly
9	Bearings and/or Spacer Sleeves, where used
10	Cylinder Link Pin
11	Inspection/Access Cover
12	Bolt (Hex Head Capscrew)
13	Flat Washer

Custom parts - call the Genesis Parts Department for part numbers specific to your serial number.

## SECOND-MEMBER MOUNT UPPER HEAD

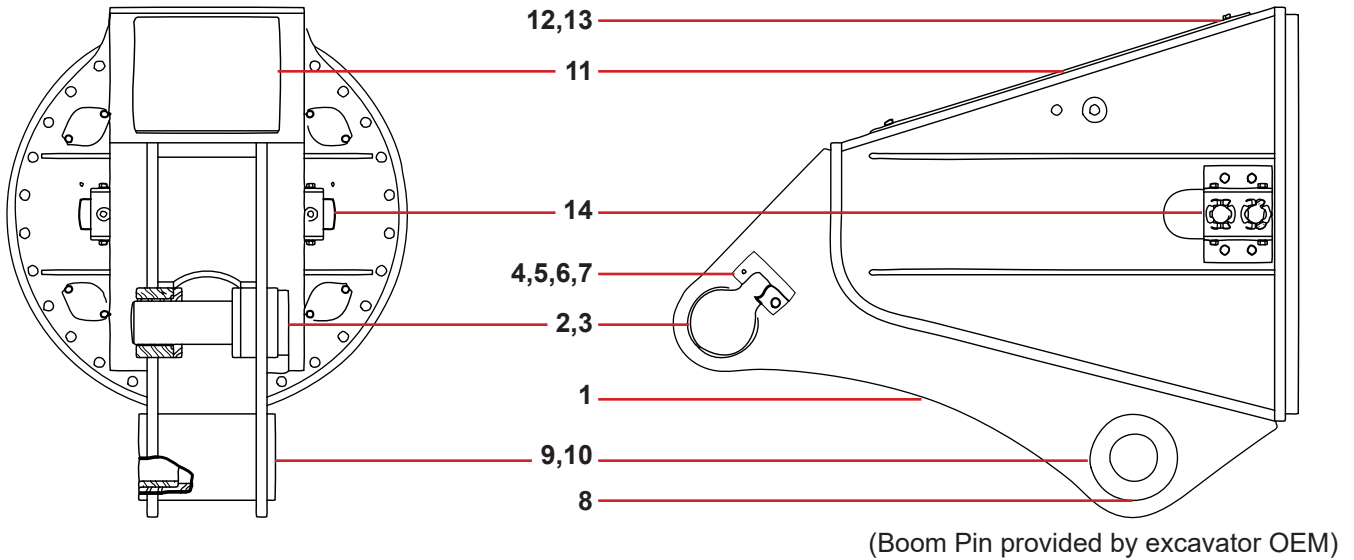

Item	Description
1	Upper Head
2	Cylinder Pin
3	Spacer Sleeves
4	Pin Keeper
5	Strap
6	Hex Head Capscrew Bolt
7	Lock Washer
8	Grease Fitting
9	Boom Bearings
10	Machine Bearings, where used
11	Inspection/Access Cover
12	Hex Head Capscrew Bolt
13	Flat Washer
14	Port Block Assembly

Custom parts - call the Genesis Parts Department for part numbers specific to your serial number.

# MULTI-PROCESSOR BODY

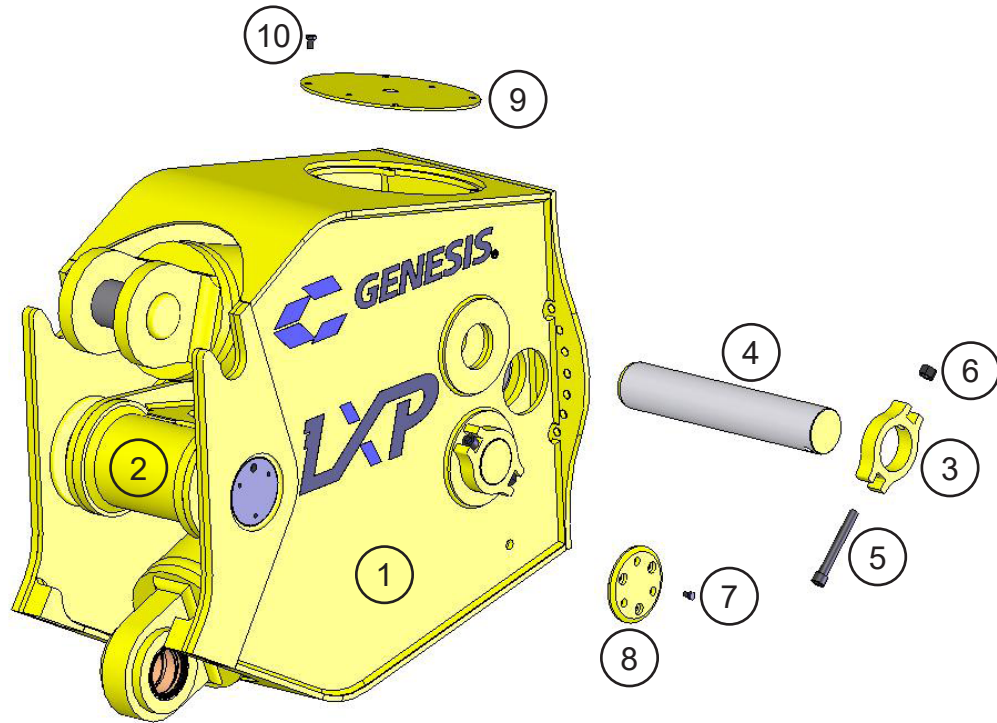

## MULTI-PROCESSOR BODY

ITEM	QTY	PART NUMBER	DESCRIPTION
1	1	3501583	Body
2	1	6350073	Lock Pin Assembly
3	2	3500022	Pin Keeper
4	2	3500636	Rear Cylinder Pin
5	2	F0620180	Bolt M20 x 2.5 x 180
6	2	F1020250	Nut
7	16	F0112030	Bolt M12 x 1.75 x 30
8	2	3500113	Safety Plate
9	2	3500015	Cover
10	8	F0112030	Bolt M12 x 1.75 x 30

# SHEAR JAW SET PIVOT GROUP

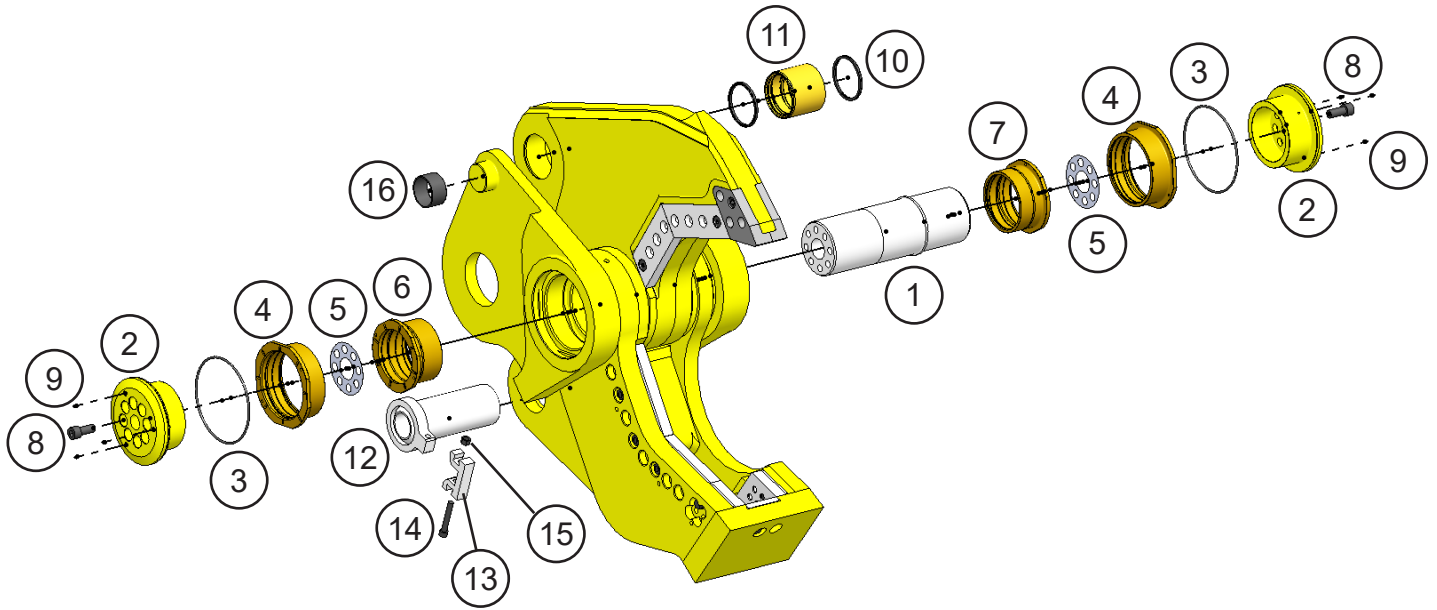



## SHEAR JAW SET PIVOT GROUP

ITEM	QTY	PART NUMBER	DESCRIPTION
1	1	3501605	Main Shaft
2	2	3501606	End Cap
3	2	S0190454	O-Ring
4	2	3501609	Quick Plate Bushing
5	2	3500032	Main Shaft Shim Set
6	1	3501607	RH Bushing
7	1	3501608	LH Bushing
8	16	F0630070	End Cap Bolt M30 x 3.5 x 70
9	8	6200002	Grease Fitting
10	2	6300805	Wiper Seal
11	1	6300804	Bushing
12	1	3501672	Lower Jaw/Cylinder Pin
13	1	1102487	Pin Keeper
14	1	F0620130	PK Bolt M20 x 2.5 x 130
15	1	F1020250	Nut
16	2	3500190	Quick Plate Trunion Bushing

# CONCRETE CRACKER JAW SET PIVOT GROUP

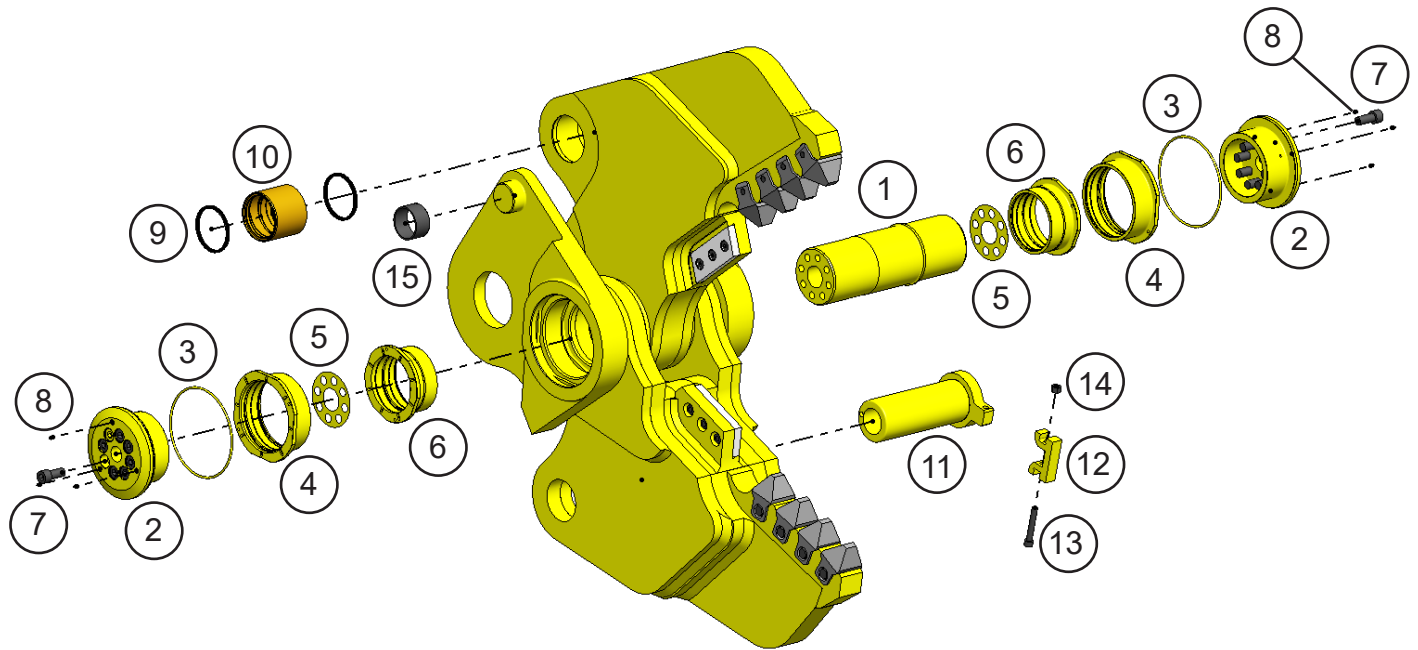

## CONCRETE CRACKER JAW SET PIVOT GROUP

ITEM	QTY	PART NUMBER	DESCRIPTION
1	1	3501621	Main Shaft
2	2	3501606	End Cap
3	2	S0190454	O-Ring
4	2	3501609	Quick Plate Bushing
5	2	3500032	Main Shaft Shim Set
6	2	3501608	LH Bushing
7	16	F0630070	End Cap Bolt M30 x 3.5 x 70
8	8	6200002	Grease Fitting
9	2	6300805	Wiper Seal
10	1	6300804	Bushing
11	1	3501674	Lower Jaw/Cylinder Pin
12	1	1102487	Pin Keeper
13	1	F0620130	PK Bolt M20 x 2.5 x 130
14	1	F1020250	Nut M20 x 2.5
15	2	3500190	Quick Plate Trunion Bushing

# CONCRETE PULVERIZER JAW SET PIVOT GROUP

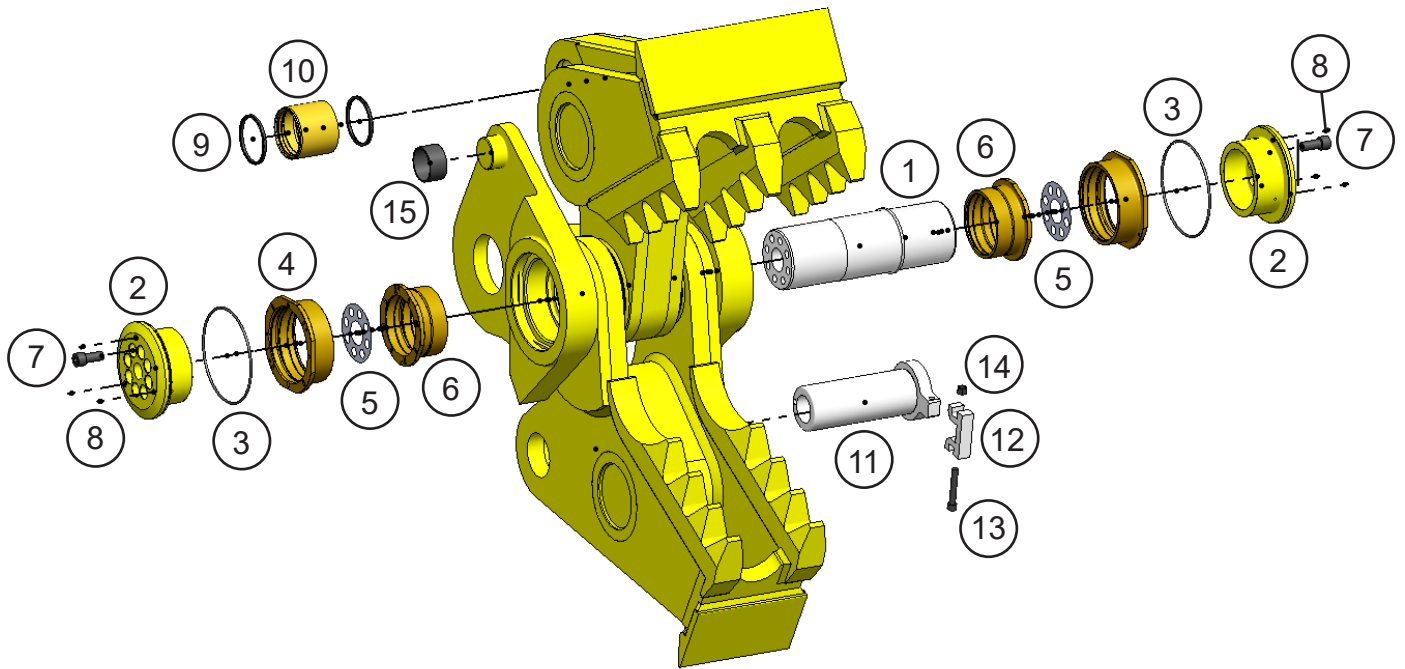

## CONCRETE PULVERIZER JAW SET PIVOT GROUP

ITEM	QTY	PART NUMBER	DESCRIPTION
1	1	3501621	Main Shaft
2	2	3501606	End Cap
3	2	S0190454	O-Ring
4	2	3501609	Quick Plate Bushing
5	2	3500032	Main Shaft Shim Set
6	2	3501608	Main Shaft Bushings
7	16	F0630070	End Cap Bolt M30 x 3.5 x 70
8	8	6200002	Grease Fitting
9	2	6300805	Wiper Seal
10	1	6300804	Bushing
11	1	3501674	Lower Jaw/Cylinder Pin
12	1	1102487	Pin Keeper
13	1	F0620130	PK Bolt M20 x 2.5 x 130
14	1	F1020250	Nut M20 x 2.5
15	2	3500190	Quick Plate Trunion Bushing

# HYDRAULICS

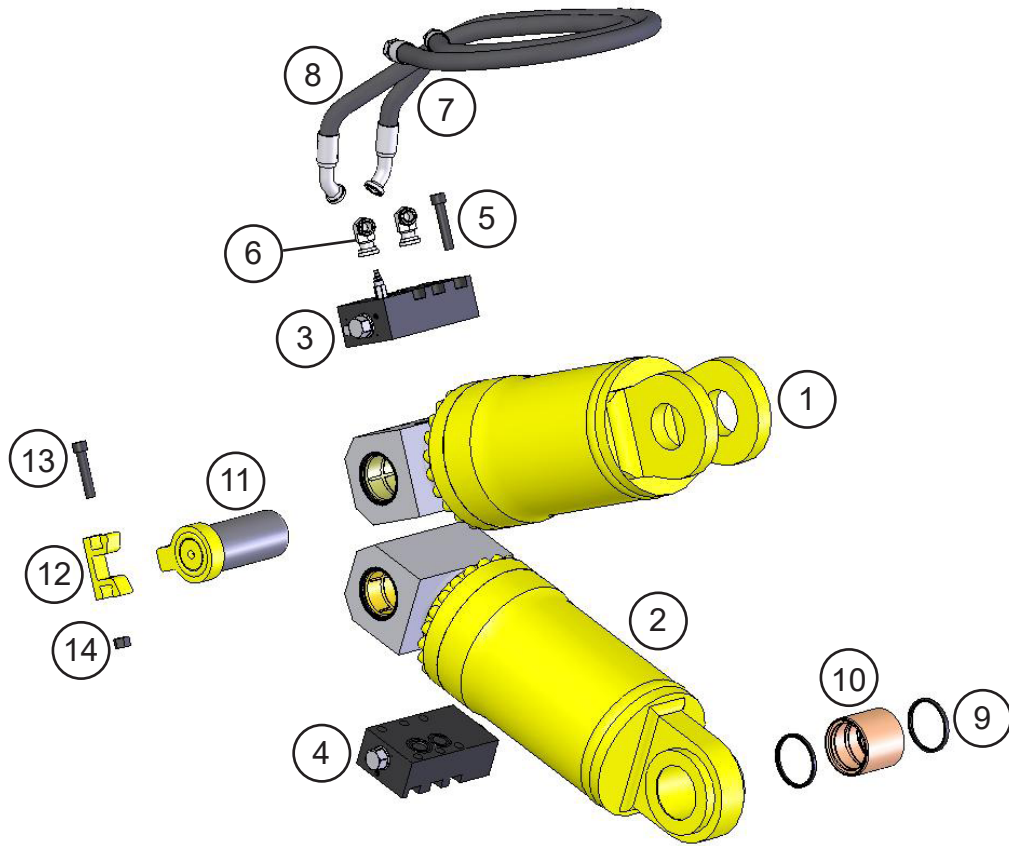

## HYDRAULICS

ITEM	QTY	PART NUMBER	DESCRIPTION
1	1	6301120	Cylinder
2	1	6301121	Cylinder
3	1	6300763	Regeneration Valve, Master
4	1	6300773	Regeneration Valve, Slave
5	12	F0620100	Regen Bolts M20 x 2.5 x 100
6	4	6310004	Adapter
7	2	5300463	Hose
8	2	5300464	Hose
9	2	6300805	Wiper Seal
10	1	6300804	Bushing
11	2	3501618	Pin
12	2	3500022	Pin Keeper
13	2	F0620180	Bolt M20 x 2.5 x 180
14	2	F1020250	Nut M20 x 2.5

# SHEAR JAW SET

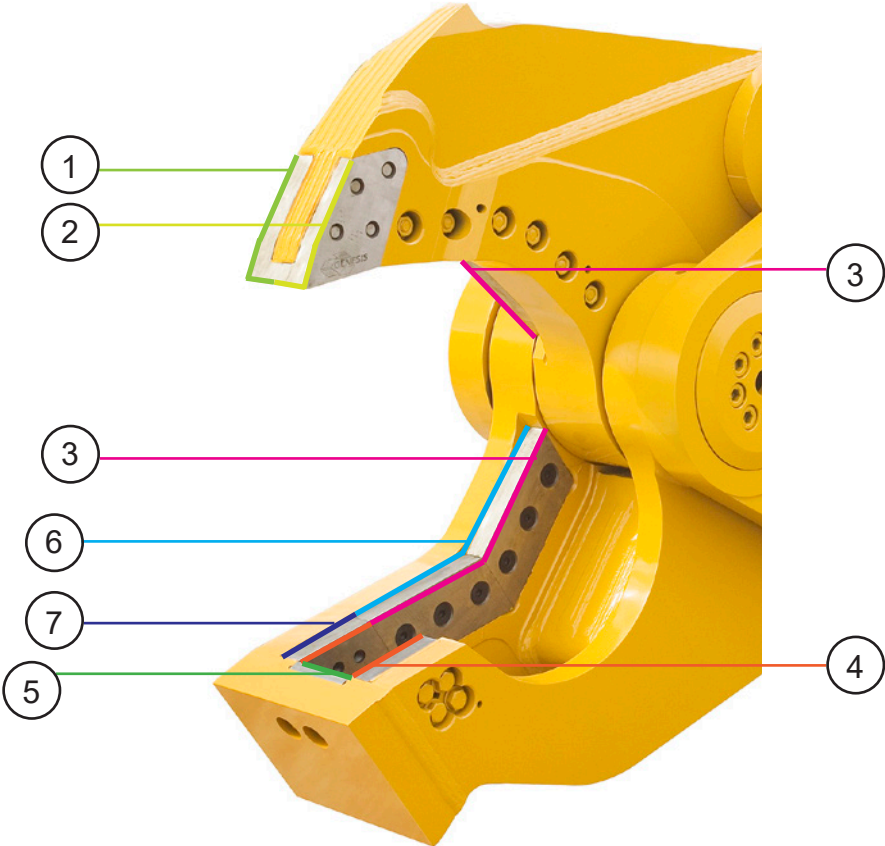



# SHEAR JAW SET

ITEM	QTY	PART NUMBER	DESCRIPTION
1	1	1103538	RH Tip Blade
2	1	1103539	LH Tip Blade
3	5	1103537	Cutting Blades
4	2	1103540	Guide Blades
5	1	1101955	Razor Blade
6	2	1103659	Blade Shim Set
7	1	1103660	Guide Shim Set

# CONCRETE CRACKER JAW SET

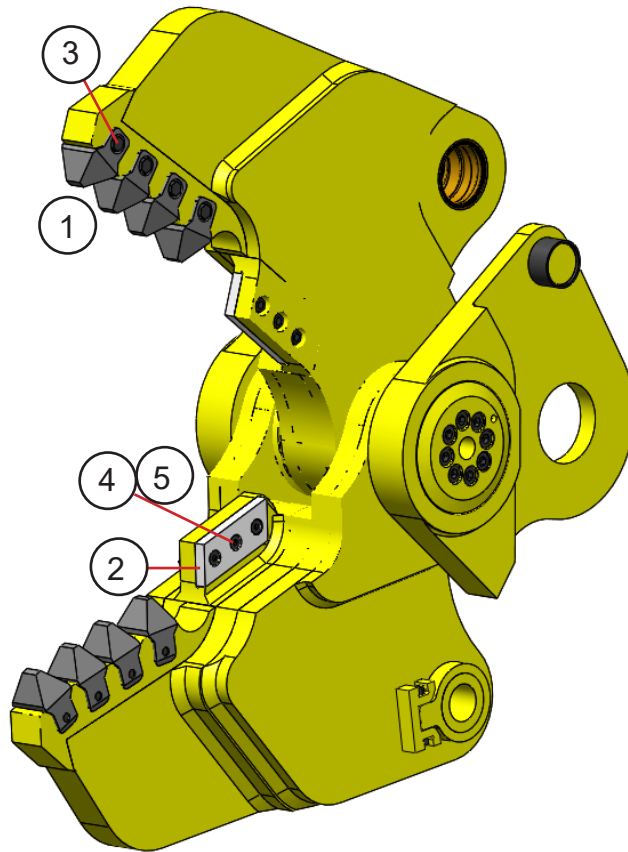

## CONCRETE CRACKER JAW SET

ITEM	QTY	PART NUMBER	DESCRIPTION
1	8	3501366	Tooth
2	2	4500396	Cutting Blade
3	8	F0288400	Tooth Bolt $\frac{7}{8}$ - 9 x 4
4	6	F0575300	Blade Bolt $\frac{3}{4}$ - 10 x 3
5	6	F0907510	Blade Nut $\frac{3}{4}$ - 10

# CONCRETE PULVERIZER JAW SET - BOLT-IN TEETH

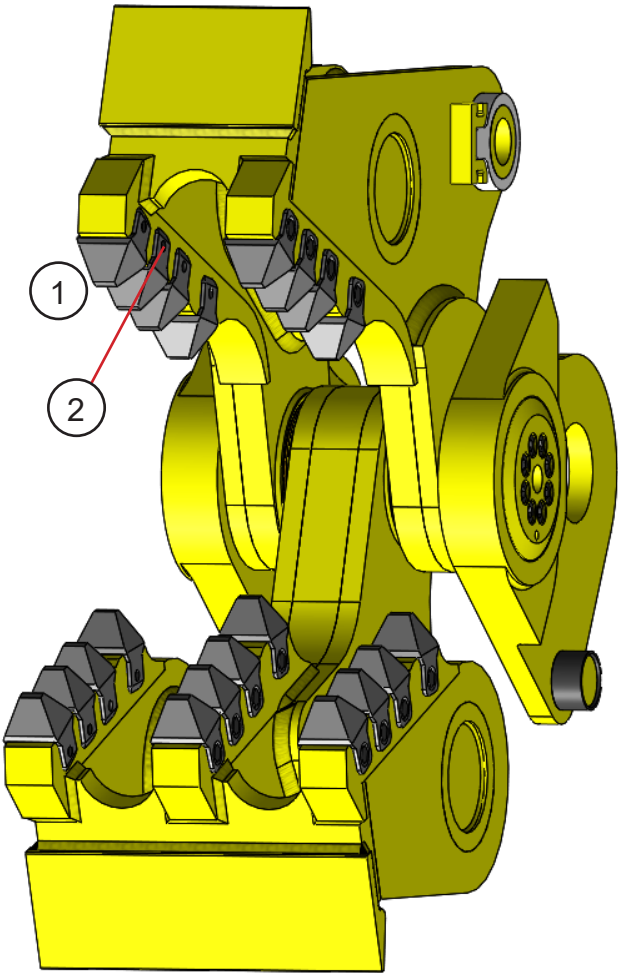

## CONCRETE PULVERIZER JAW SET - BOLT-IN TEETH

ITEM	QTY	PART NUMBER	DESCRIPTION
1	20	3501366	Tooth
2	20	F0288400	Tooth Bolt $\frac{7}{8}$ - 9 x 4

# ROTATION DRIVE SYSTEM

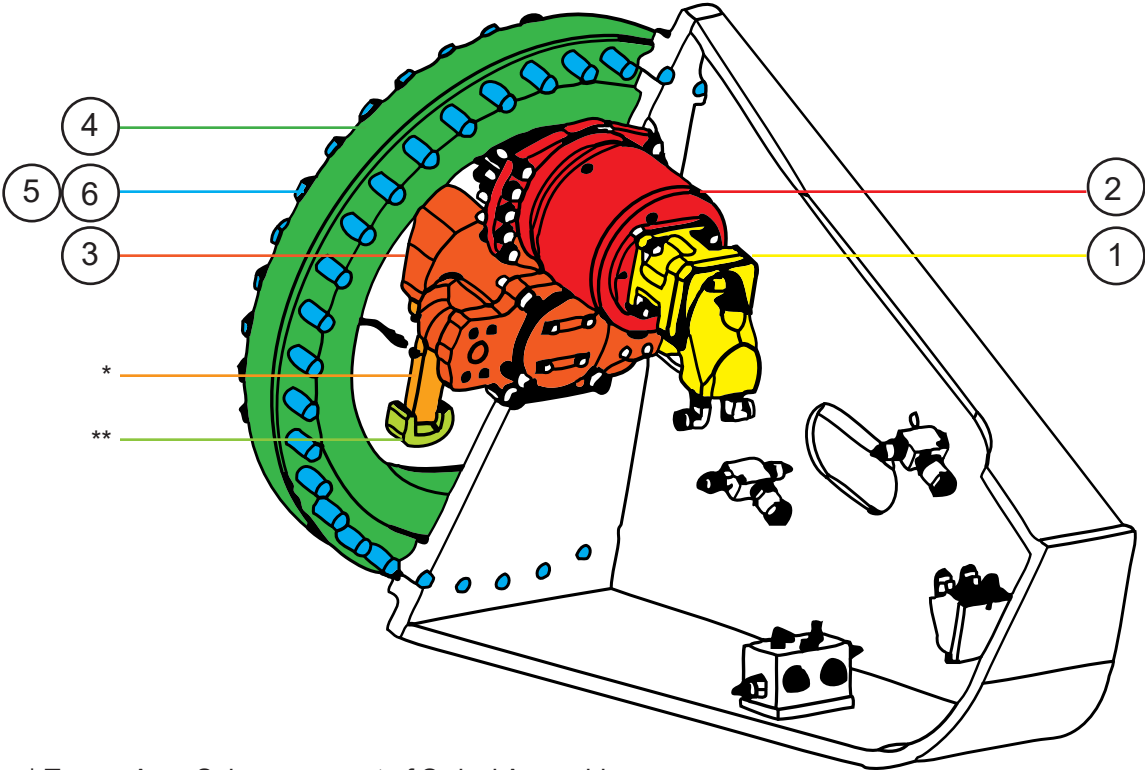

\* Torque Arm, Sub-component of Swivel Assembly  
\*\* Torque Arm Stop, Sub-component of Swivel Assembly

## ROTATION DRIVE SYSTEM

ITEM	QTY	PART NUMBER	DESCRIPTION
1	1	6340012	Motor
2	1	6300446	Gearbox
3	1	6350070	Swivel Assembly
4	1	6300430	Rotation Bearing
5	72	F0130150	Bolts M30 x 3.5 x 150
6	72	F2803000	Washers M30

# ELECTRICAL

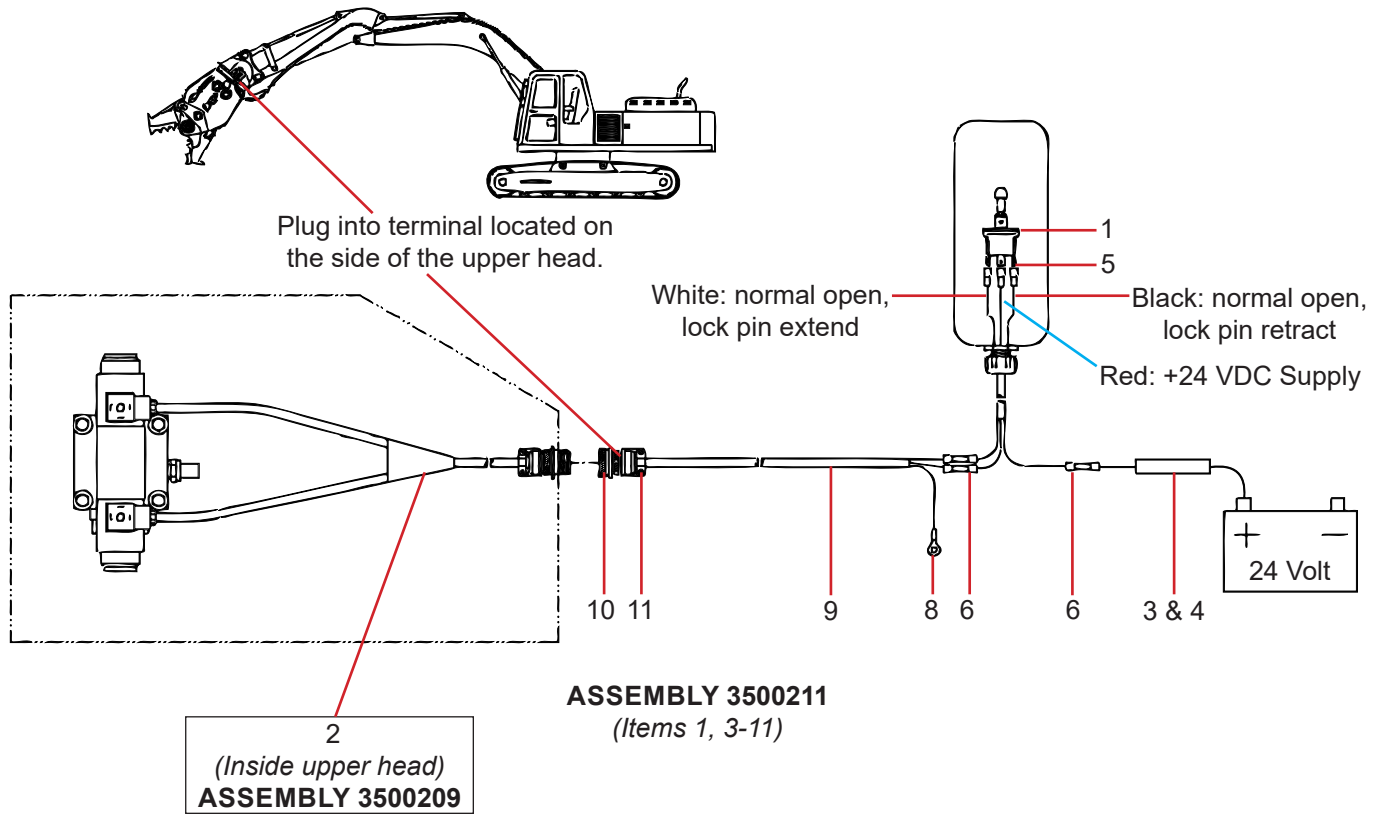

Item	Description	Part Number
1	Mount three-way locking toggle switch in excavator cab	3500211
2	Lock pin wiring harness sub-assembly	3500209
3	Fuse holder	Included in 3500211
4	Two-amp fuse	
5	Insulated connectors	
6	Butt connectors: white to white, black to black, red to fuse/battery	
7	Cable ties (not shown)	
8	Insulated ring terminal; green to ground	
9	Cable; use cable ties to secure along stick/boom	
10	Plug connector into terminal located on the side of the upper head	
11	Cable clamp	



## BOLT TORQUE SPECIFICATIONS

Reference the product Thread Treatment Diagrams beginning on page 26 to determine whether to use wet or dry torque values for specific bolts.

Reference Procedures on page 28 for threadlocker or anti-seize application and bolt and bolt hole cleaning.

Prior to torquing, clean all bolt holes, bolts and nuts to remove dirt, grease and oil, and identify bolt type.

Never re-torque bolts that use Loctite. If a bolt becomes loose or damaged after the initial use when Loctite was applied and the bolt was torqued, the bolt must be replaced.

Never break tightened bolts loose with a torque wrench. Doing so may break the torque wrench or take it out of calibration.

Torque wrenches should be calibrated on an annual basis.

When using a torque multiplier with a torque wrench, incorrect settings will be multiplied by the ratio of the torque wrench.

Never use an impact driver on a torque multiplier.

# THREAD TREATMENT DIAGRAM

## Mobile Shears

Use this diagram to determine what thread treatment, if any, is required for each fastener.

For thread treatment application procedures, see page 28. For prescribed torque values, see page 30.

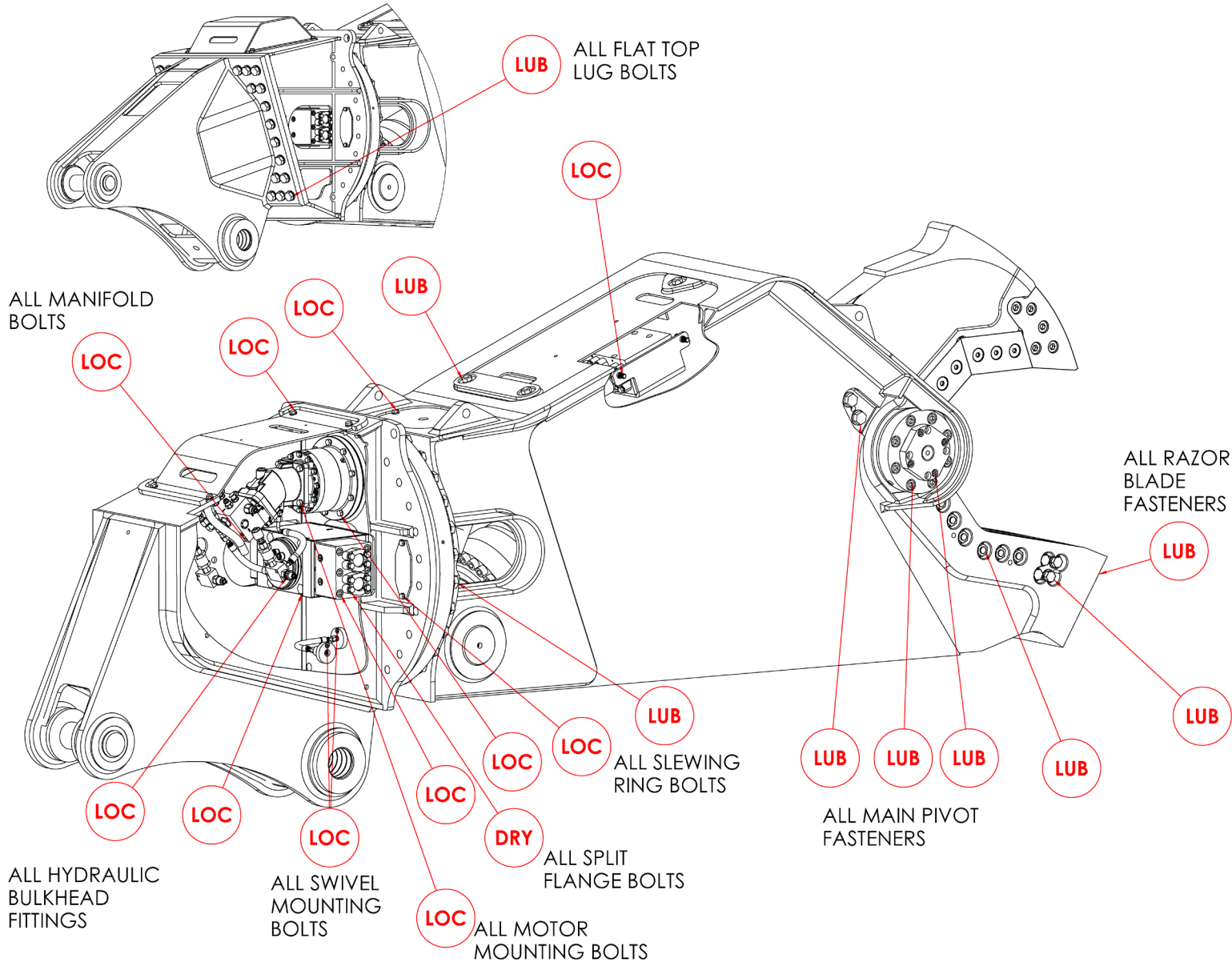

# THREAD TREATMENT DIAGRAM

## Processors

Use this diagram to determine what thread treatment, if any, is required for each fastener.

For thread treatment application procedures, see page 28. For prescribed torque values, see page 30.

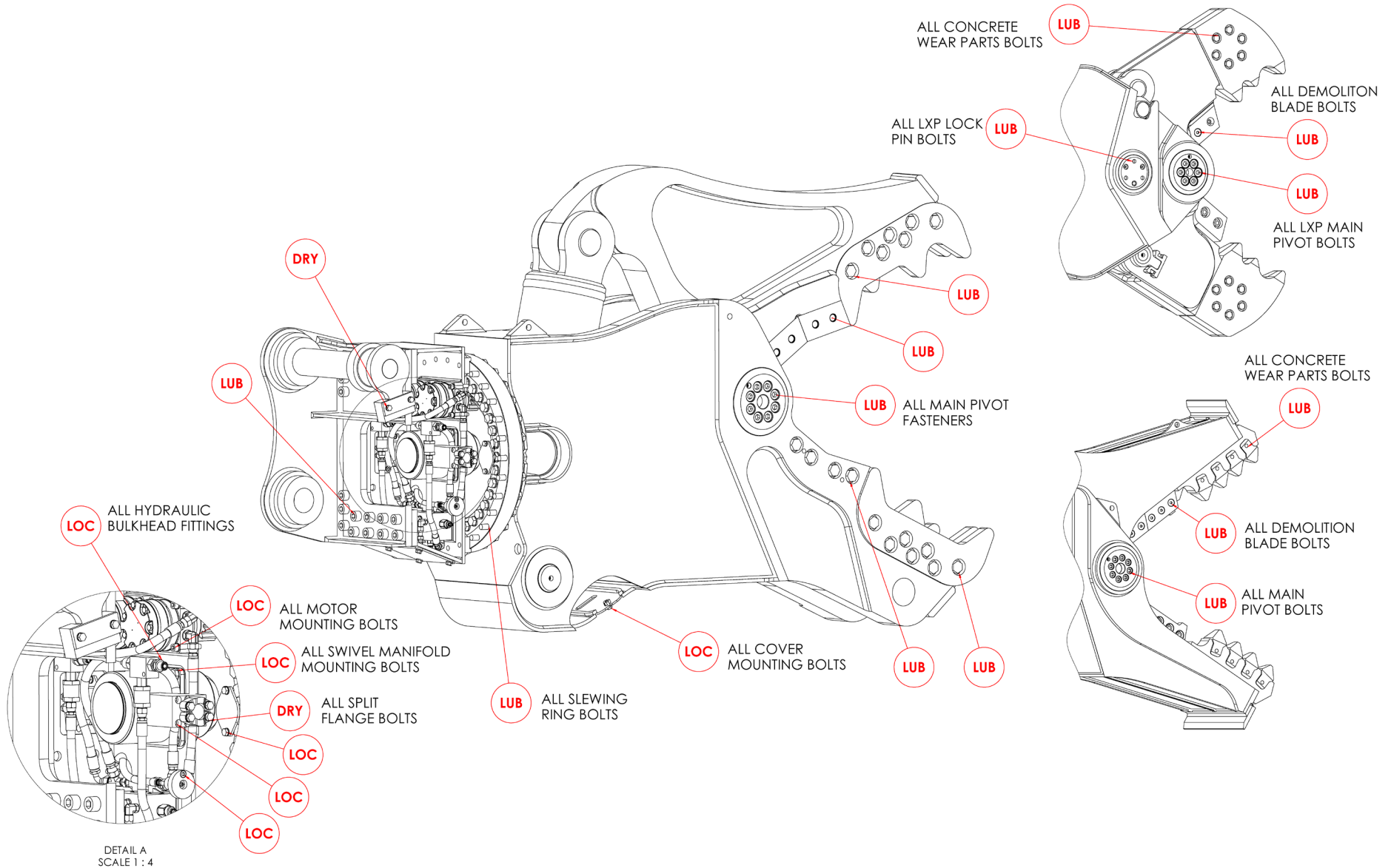

# PROCEDURES

Reference the product Thread Treatment Diagrams beginning on page 26 to determine which of the following procedures is required.

## Cleaning

To ensure proper performance of thread treatment and accurate torque values, clean and degrease **all internal and external threads** prior to application of threadlocker, anti-seize or primer and before installation of hardware.

- Ensure both internal and external threads are free of dirt or debris.
- Use brake cleaner or similar cleaning solvent on all threads to remove any grease or oil.
- Allow threads to dry.

## NOTICE

Failure to properly clean threads will cause threadlocker, primer, and/or anti-seize to not properly cure!

LOC

## Threadlocker

For bolted connections requiring threadlocker, use **Loctite 263** or equivalent applied using the following procedure:

- Clean and degrease all threads.
- For thru holes or nuts, apply threadlocker to bolt threads.
- For blind holes, apply stripe of threadlocker along the length of the hole (applying to the bolt can cause escaping air to remove threadlocker as the bolt is inserted).
- Torque bolt to specified **Wet Torque Value**, see page 30.

For threaded hydraulic fitting connections, use **Loctite 5452** or equivalent thread sealant in conjunction with **Loctite 7471** primer using the following procedure:

- Clean and degrease all threads.
- Apply Loctite 7471 primer to both external and internal threads and allow to dry.
- Apply threadlocker to 360 degrees of the threads on the male fitting, ensuring adequate coverage.
- Assemble fitting per directions in operator's manual.
- For O-ring boss and flat face O-ring connections, torque fittings to values specified on page 31.

Threadlocker

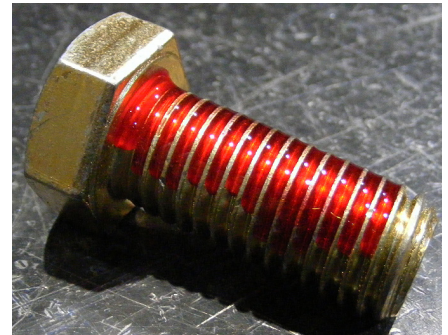

Blind Hole

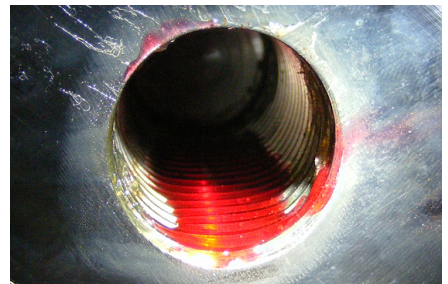

Hydraulic Fitting



## PROCEDURES

LUB

### Anti-Seize

For bolted connections requiring anti-seize lubrication, use **Loctite LB8008** or equivalent using the following procedure:

- Clean and degrease all threads.
- Apply thin coat of anti-seize to internal and external threads and under bolt head and/or nut, ensuring complete coverage.
- Torque bolt to specified **Wet Torque Value**, see page 30.

Anti-Seize









DRY

### No Thread Treatment

- Clean and degrease all threads.
- Torque bolt to specified **Dry Torque Value**, see page 30.

# BOLT TORQUE SPECIFICATIONS

<b>Dry Torque Values</b>					
		<b>Hex/Socket Head</b>		<b>Flat Head</b>	
					
Fastener Grade	Size x Pitch	Nm	Ft-lb	Nm	Ft-lb
CL 10.9	M8 x 1.25	35	26	27	20
	M10 x 1.50	71	53	58	42
	M12 x 1.75	124	92	101	73
	M14 x 1.50	200	148	163	118
	M14 x 2.00	200	148	163	118
	M16 x 2.00	311	230	254	184
	M20 x 1.50	610	450	498	360
	M20 x 2.50	608	449	497	359
	M24 x 3.00	1054	778	861	622
	M27 x 3.00	1543	1138	1260	910
	M30 x 3.50	2095	1545	1712	1236
	M36 x 4.00	3659	2699	2991	2159
8	1/4-20	14	11	11	8
	5/16-18	32	24	26	19
	3/8-16	59	44	48	35
	7/16-14	94	70	77	56
	1/2-13	143	106	116	84
	1/2-20	162	120	133	96
	5/8-11	287	212	234	169
	3/4-10	509	376	415	300
	7/8-9	821	606	670	484
	1.00-8	1232	909	1007	727
	1.00-14	1383	1020	1130	816
	1.25-7	2463	1817	2013	1453
L9	1.50-6	4287	3162	3504	2529

<b>Wet Torque Values</b>					
		<b>Hex/Socket Head</b>		<b>Flat Head</b>	
					
Fastener Grade	Size x Pitch	Nm	Ft-lb	Nm	Ft-lb
CL 10.9	M8 x 1.25	29	22	23	17
	M10 x 1.50	61	45	49	36
	M12 x 1.75	105	78	85	62
	M14 x 1.50	150	111	121	88
	M14 x 2.00	170	126	138	100
	M16 x 2.00	265	196	216	156
	M20 x 1.50	456	337	372	269
	M20 x 2.50	517	382	422	305
	M24 x 3.00	894	660	731	528
	M27 x 3.00	1312	968	1072	774
	M30 x 3.50	1779	1312	1453	1049
	M36 x 4.00	3110	2294	2542	1835
8	1/4-20	13	10	11	8
	5/16-18	27	20	22	16
	3/8-16	50	37	40	29
	7/16-14	80	59	65	47
	1/2-13	122	90	99	72
	1/2-20	138	102	112	81
	5/8-11	244	180	199	144
	3/4-10	433	320	354	256
	7/8-9	698	515	570	412
	1.00-8	1046	772	854	617
	1.00-14	1175	867	960	693
	1.25-7	2095	1545	1712	1236
L9	1.50-6	3644	2688	2979	2150

# O-RING BOSS & FLAT FACE O-RING TORQUE SPECIFICATIONS

O-Ring Boss Torque Values		
Size Dash	Nm	Ft-lb
-4	22	16
-5	27	20
-6	36	26
-8	83	60
-10	110	80
-12	187	135
-14	249	180
-16	304	220
-20	387	280
-24	498	360

Flat Face O-Ring Torque Values		
Size Dash	Nm	Ft-lb
-4	18	13
-6	30	22
-8	60	44
-10	85	62
-12	121	88
-14	121	88
-16	160	116
-20	213	154
-24	274	198

# BOLT DRIVE SPECIFICATIONS

Thread Size x Pitch	Hex Head	Socket Head	Flat Head
			
	Wrench/Drive Size		
M8 x 1.25	13mm	6mm	5mm
M10 x 1.50	17mm	8mm	6mm
M12 x 1.75	19mm	10mm	8mm
M14 x 1.50	22mm	12mm	10mm
M14 x 2.00	22mm	12mm	10mm
M16 x 2.00	24mm	14mm	10mm
M20 x 1.50	30mm	17mm	12mm
M20 x 2.50	30mm	17mm	12mm
M24 x 3.00	36mm	19mm	14mm
M27 x 3.00	41mm	19mm	-
M30 x 3.50	46mm	22mm	-
M36 x 4.00	55mm	27mm	-
1/4-20	7/16"	3/16"	5/32"
5/16-18	1/2"	1/4"	3/16"
3/8-16	9/16"	5/16"	7/32"
7/16-14	5/8"	3/8"	1/4"
1/2-13	3/4"	3/8"	5/16"
1/2-20	3/4"	3/8"	5/16"
5/8-11	15/16"	1/2"	3/8"
3/4-10	1-1/8"	5/8"	1/2"
7/8-9	1-5/16"	3/4"	9/16"
1.00-8	1-1/2"	3/4"	5/8"
1.00-14	1-1/2"	3/4"	5/8"
1.25-7	1-7/8"	7/8"	7/8"
1.50-6	2-1/4"	1"	1"



## TOOL LIST

The following is a list of tools available for purchase from Genesis. This list may not include every tool used for this attachment, such as those that would also commonly be used for maintaining an excavator.

Part Number	Description
6900001	Service tool kit - includes part numbers 6900002 through 6900020
6900002	1-1/2" 12-point socket, 1" drive
6900003	1-5/16" 12-point socket, 1" drive
6900004	5/8" impact hex bit socket, 3/4" drive
6900005	3/4" impact hex bit socket, 3/4" drive
6900006	3/4" drive female to 1" drive male adapter
6900007	1-1/4" combo wrench
6900008	Jet needle scaler
6900009	17mm socket, 3/4" drive, metric impact
6900010	Torque multiplier, 2000 ft/lb
6900011	3/4" drive torque wrench, 600 ft/lb
6900012	26" male/female ratchet, 1" drive
6900013	30" ratchet, 1" drive
6900014	5/16" LA hex key
6900015	1-5/16" combo wrench
6900016	7/8" combo wrench
6900017	1-1/8" combo wrench
6900018	40mm 6-point impact socket, 3/4" drive
6900019	46mm 6-point impact socket, 3/4" drive
6900020	Tool box
6900021	7/8" impact hex bit socket, 3/4" drive
6900022	1-1/2" 6-point socket, 1" drive
6900023	7/8" impact hex bit socket, 1" drive
6900024	36mm 6-point impact socket, 1" drive

# WARRANTY

## **Claim Procedure**

Notify the Genesis Service Department of the potential warranty claim prior to making the repair. Digital pictures are very helpful for diagnosing problems and recommending repairs.

Contact the Genesis Service Department before making alterations, changes or repairs to any component that is going to be considered for warranty. Not doing so will void all Genesis warranty consideration.

The Genesis Service Department will issue an authorization number to track the repair costs, outgoing parts, and/or defective parts returning to the factory.

Replacement parts must be ordered using a purchase order number. Shipping is standard ground. Overnight shipping is available by request, and Genesis will not cover the shipping charge.

When the repair is complete, submit an invoice to the Genesis Service Department within 30 days. Include itemized internal labor reporting, parts lists and invoices for outside contractors. Reference the authorization number on all invoices.

When returning parts for warranty consideration, include a copy of any related Genesis paperwork along with any other necessary documentation to ensure proper processing and credit. The Genesis Service Department will provide the necessary forms.

Your account will be credited when the warranty claim is accepted.

## **Blade Warranty**

Standard warranty on blades will only be considered on the first edge, and wear on the edge must be 1/8" radius or less. Genesis does not warranty cutting blades that are cracked or broken from top to bottom (perpendicular to the long edge of the blade). Genesis also does not cover fasteners, the labor to replace wear components or collateral damage, such as blade seats, from broken blades, the piercing blade tang or adjustment plates.

**Please direct any questions to the Genesis Service Department: 715-395-5252**

# PARTS ORDER POLICY AND PROCEDURE

## **Parts Orders Should Include**

- Purchase order number
- Model and serial number of attachment
- Part number and quantity needed
- Shipping and billing address
- Method of shipment or required delivery date

## **Placing Orders**

Orders may be placed by phone or e-mail. To e-mail an order, use the form on the following page or your purchase order form. Contact information is located at the front of this manual.

## **Part Numbers**

Part numbers are listed in a separate Parts Manual or, if included, the Parts section of this manual. Contact the Genesis Parts Department with questions regarding part numbers, availability and pricing.

## **Shipping**

All orders will be shipped best way surface unless an alternate shipping method is requested. Shipping charges are not included in the purchase price of parts.

## **Invoices**

All invoices are due upon receipt. Any accounts with invoices open beyond 60 days are subject to review and may be placed on C.O.D. status without further notice.

## **Returns**

Many unused Genesis parts may be returned with proper documentation. Return shipping is the responsibility of the purchaser. Credit will be issued upon return, less a 25% restocking fee. Documentation is required for credit of returned parts. Contact the Genesis Service Department at 715-395-5252 for an RGA (Return Goods Authorization) number and form. An RGA must accompany every return. Items shipped without an RGA may be returned to sender.

## **Warranty Returns**

All parts returned to Genesis for warranty consideration must be returned with a completed RGA (Return Goods Authorization) provided by the Genesis Service Department. The form needs to be completed in its entirety, including any additional information requested by the Service Department. Return shipping is the responsibility of the sender and will be credited upon claim approval. A determination to accept or deny the claim will be made based upon the information available to Genesis. Warranty on purchased parts other than wear components is 6 months. Genesis does not cover labor costs to replace purchased parts replaced under warranty. There is no warranty period on wear parts or components.



# INDEX

- 1101955 Razor Blade 17
- 1102487 Pin Keeper 9, 11, 13
- 1103537 Cutting Blades 17
- 1103538 RH Tip Blade 17
- 1103539 LH Tip Blade 17
- 1103540 Guide Blades 17
- 1103659 Blade Shim Set 17
- 1103660 Guide Shim Set 17
- 3500015 Cover 7
- 3500022 Pin Keeper 7, 15
- 3500032 Main Shaft Shim Set 9, 11, 13
- 3500113 Safety Plate 7
- 3500190 Quick Plate Trunion Bushing 9, 11, 13
- 3500209 24
- 3500211 24
- 3500636 Rear Cylinder Pin 7
- 3501366 Tooth 19, 21
- 3501583 Body 7
- 3501605 Main Shaft 9
- 3501606 End Cap 9, 11, 13
- 3501607 RH Bushing 9
- 3501608 LH Bushing 9, 11, 13
- 3501609 Quick Plate Bushing 9, 11, 13
- 3501618 Pin 15
- 3501621 Main Shaft 11, 13
- 3501672 Lower Jaw/Cylinder Pin 9
- 3501674 Lower Jaw/Cylinder Pin 11, 13
- 4500396 Cutting Blade 19
- 5300463 Hose 15
- 5300464 Hose 15
- 6200002 Grease Fitting 9, 11, 13
- 6300430 Rotation Bearing 23
- 6300446 Gearbox 23
- 6300763 Regeneration Valve, Master 15
- 6300773 Regeneration Valve, Slave 15
- 6300804 Bushing 9, 11, 13, 15
- 6300805 Wiper Seal 9, 11, 13, 15
- 6301120 Cylinder 15
- 6301121 Cylinder 15
- 6310004 Adapter 15
- 6340012 Motor 23
- 6350070 Swivel Assembly 23
- 6350073 Lock Pin Assembly 7
- 6900001 Service Tool Kit 33
- 6900002 1-1/2" 12-point socket, 1" drive 33
- 6900003 1-5/16" 12-point socket, 1" drive 33
- 6900004 5/8" impact hex bit socket, 3/4" drive 33
- 6900005 3/4" impact hex bit socket, 3/4" drive 33
- 6900006 3/4" drive female to 1" drive male adapter 33
- 6900007 1-1/4" combo wrench 33
- 6900008 Jet needle scaler 33
- 6900009 17mm socket, 3/4" drive, metric impact 33
- 6900010 Torque multiplier, 2000 ft/lb 33
- 6900011 3/4" drive torque wrench, 600 ft/lb 33
- 6900012 26" male/female ratchet, 1" drive 33
- 6900013 30" ratchet, 1" drive 33
- 6900014 5/16" LA hex key 33
- 6900015 1-5/16" combo wrench 33
- 6900016 7/8" combo wrench 33
- 6900017 1-1/8" combo wrench 33
- 6900018 40mm 6-point impact socket, 3/4" drive 33
- 6900019 46mm 6-point impact socket, 3/4" drive 33
- 6900020 Tool box 33
- 6900021 7/8" impact hex bit socket, 3/4" drive 33
- 6900022 1-1/2" 6-point socket, 1" drive 33
- 6900023 7/8" impact hex bit socket, 1" drive 33
- 6900024 36mm 6-point impact socket, 1" drive 33
- Bearings 4
- Bolt Drive Specifications 32
- Bolt Torque Specifications 25, 30
- Boom Bearings 5
- Concrete Cracker Jaw Set 18, 19
- Concrete Cracker Jaw Set Pivot Group 10, 11
- Concrete Pulverizer Jaw Set - Bolt-In Teeth 20, 21
- Concrete Pulverizer Jaw Set Pivot Group 12, 13
- Contact Information 2, 39
- Cylinder Link Pin 4
- Cylinder Pin 5
- Electrical 24
- F0112030 Bolt M12 x 1.75 x 30 7
- F0130150 Bolts M30 x 3.5 x 150 23
- F0288400 Tooth Bolt 7/8 - 9 x 4 19, 21
- F0575300 Blade Bolt 3/4 - 10 x 3 19
- F0620100 Regen Bolts M20 x 2.5 x 100 15
- F0620130 PK Bolt M20 x 2.5 x 130 9, 11, 13
- F0620180 Bolt M20 x 2.5 x 180 7, 15
- F0630070 End Cap Bolt M30 x 3.5 x 70 9, 11, 13
- F0907510 Blade Nut 3/4 - 10 19
- F1020250 Nut M20 x 2.5 7, 9, 11, 13, 15
- F2803000 Washers M30 23
- Flat Washer 4, 5
- Grease Fitting 5
- Hex Head Capscrew Bolt 4, 5
- Hydraulics 14, 15
- Inspection/Access Cover 4, 5
- Lock Washer 4, 5
- Machine Bearings 5
- Multi-Processor Body 6, 7
- O-Ring Boss & Flat Face O-Ring Torque Specifications 31
- Parts Order Form 36
- Parts Order Policy and Procedure 35
- Pin Keeper 4, 5
- Port Block Assembly 4, 5
- Procedures 28, 29
- Rotation Drive System 22, 23
- S0190454 O-Ring 9, 11, 13
- Second-Member Mount Upper Head 5

# INDEX

Shear Jaw Set 16, 17  
Shear Jaw Set Pivot Group 8, 9  
Spacer Sleeves 4, 5  
Stick Pin 4  
Strap 4, 5  
Table of Contents 3  
Third-Member Mount Upper Head 4  
Thread Treatment Diagram 26, 27  
Tool List 33  
Upper Head 4, 5  
Warranty 34

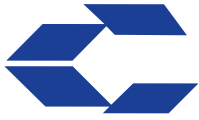

**GENESIS®**

The Promise of Performance.

## CONTACT INFORMATION

### Genesis Attachments

1000 Genesis Drive  
Superior, WI 54880 USA

Toll Free: 888-SHEAR-IT  
(888-743-2748)

Phone: 715.395.5252

E-mail:  
info@genesisattachments.com

### Europe/Africa/Middle East Genesis GmbH

Teramostrasse 23  
87700 Memmingen, Germany

Phone: +49 83 31 9 25 98 0

Fax: +49 83 31 9 25 98 80

genesis-europe.com

E-mail:  
info@genesis-europe.com

### Asia Pacific Representative Office

24 Upper Serangoon View #12-28  
Singapore 534205

Phone: +65 9673 9730

E-mail:  
tchoo@genesisattachments.com

### Central America & Colombia

Cra 13A #89-38 / Ofi 613  
Bogota, Colombia

Phone: +57 1 610 8160 / 795 8747

E-mail:  
contact@themsagroup.com

View and download all manuals: [genesisattachments.com/manuals](http://genesisattachments.com/manuals)  
Patents: [genesisattachments.com/products/patents](http://genesisattachments.com/products/patents)