

GENESIS®

The Promise of Performance.

Scrap Grapple

Standard and Heavy-Duty

PARTS MANUAL



CONTACT INFORMATION

Genesis Attachments

1000 Genesis Drive
Superior, WI 54880 USA

Toll Free: 888-SHEAR-IT
(888-743-2748)

Phone: 715.395.5252

E-mail:
info@genesisattachments.com

Europe/Africa/Middle East Genesis GmbH

Teramostrasse 23
87700 Memmingen, Germany

Phone: +49 83 31 9 25 98 0
Fax: +49 83 31 9 25 98 80
genesis-europe.com

E-mail:
info@genesis-europe.com

Asia Pacific Representative Office

24 Upper Serangoon View #12-28
Singapore 534205

Phone: +65 9673 9730

E-mail:
tchoo@genesisattachments.com

Central America & Colombia

Cra 13A #89-38 / Ofi 613
Bogota, Colombia

Phone: +57 1 610 8160 / 795 8747

E-mail:
contact@themsagroup.com

View and download all manuals: genesisattachments.com/manuals
Patents: genesisattachments.com/products/patents

TABLE OF CONTENTS

CONTACT INFORMATION	2
GENERAL ARRANGEMENT	4
GSG 50/65/75 ASSEMBLY FRAME / TINE	6
GSG 100/125 ASSEMBLY FRAME / TINE LIGHT WEIGHT	8
GSG 100/125 ASSEMBLY FRAME / TINE	10
GSG 150/200/250 ASSEMBLY FRAME / TINE	12
GSG 50/65/75/100/125 ASSEMBLY UPPER HEAD - 2200500	14
GSG 150/200/250 ASSEMBLY UPPER HEAD - 2200290	16
ASSEMBLY ROTATION	18
GSG 50/65/75 ASSEMBLY CYLINDER - 6350091	20
GSG 100/125 ASSEMBLY CYLINDER - 6350071	22
GSG 150/200/250 ASSEMBLY CYLINDER - 6350072	24
ASSEMBLY GLAND SEALS	26
ASSEMBLY PISTON SEALS	28
ASSEMBLY SWIVEL - 6350089	30
ASSEMBLY SWIVEL SEALS - DETAILED VIEW	32
ASSEMBLY HYDRAULIC	34
CARTRIDGE, CROSSPORT RELIEF - 6300902	36
CARTRIDGE, CROSSPORT RELIEF - 6300817	37
ASSEMBLY YOKE (FORKED STICK)	38
ASSEMBLY YOKE	40
BOLT TORQUE SPECIFICATIONS	42
THREAD TREATMENT DIAGRAM	43
Grapples.....	43
PROCEDURES	44
Cleaning.....	44
Threadlocker.....	44
Anti-Seize.....	45
No Thread Treatment.....	45
BOLT TORQUE SPECIFICATIONS	46
Dry Torque Values.....	46
Wet Torque Values.....	46
O-RING BOSS & FLAT FACE O-RING TORQUE SPECIFICATIONS	47
BOLT DRIVE SPECIFICATIONS	48
WARRANTY	49
Claim Procedure.....	49
Blade Warranty.....	49
PARTS ORDER POLICY AND PROCEDURE	50
Parts Orders Should Include.....	50
Placing Orders.....	50
Part Numbers.....	50
Shipping.....	50
Invoices.....	50
Returns.....	50
Warranty Returns.....	50
PARTS ORDER FORM	51
INDEX	52
CONTACT INFORMATION	54

GENERAL ARRANGEMENT

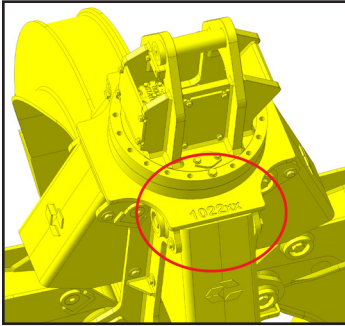

GSG Serial
Number Location

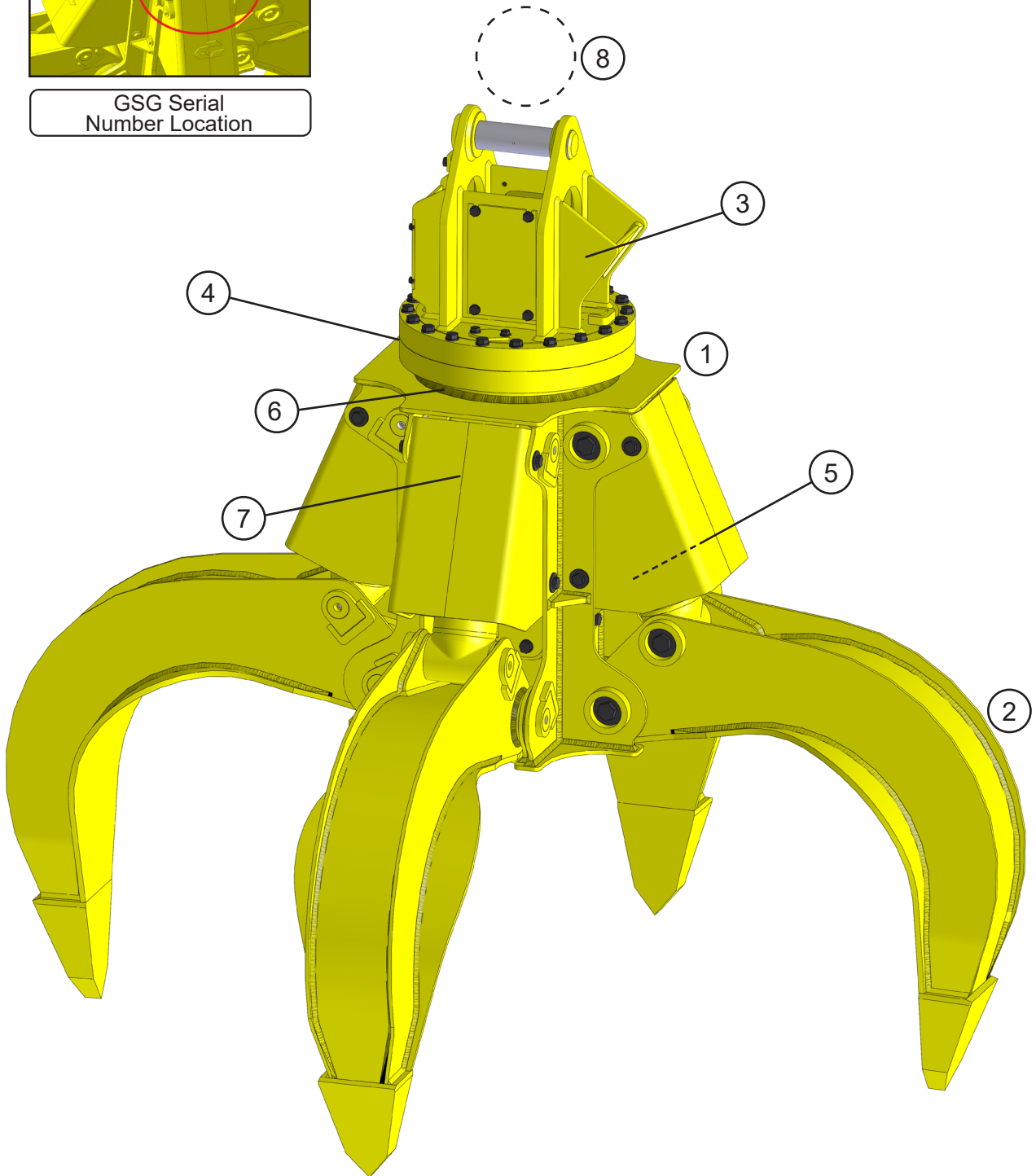

GENERAL ARRANGEMENT

ITEM	QTY	PART NUMBER	DESCRIPTION
1	1	See page 6 - 12	Assembly Frame
2	1	See page 6 - 12	Assembly Tine
3	1	See page 14 - 16	Assembly Head
4	1	See page 18	Assembly Rotation
5	1	See page 20 - 24	Assembly Cylinder
6	1	See page 30 - 32	Assembly Swivel
7	1	See page 34	Assembly Hydraulic
8	1	See page 38 - 40	Assembly Yoke

GSG 50/65/75 ASSEMBLY FRAME / TINE

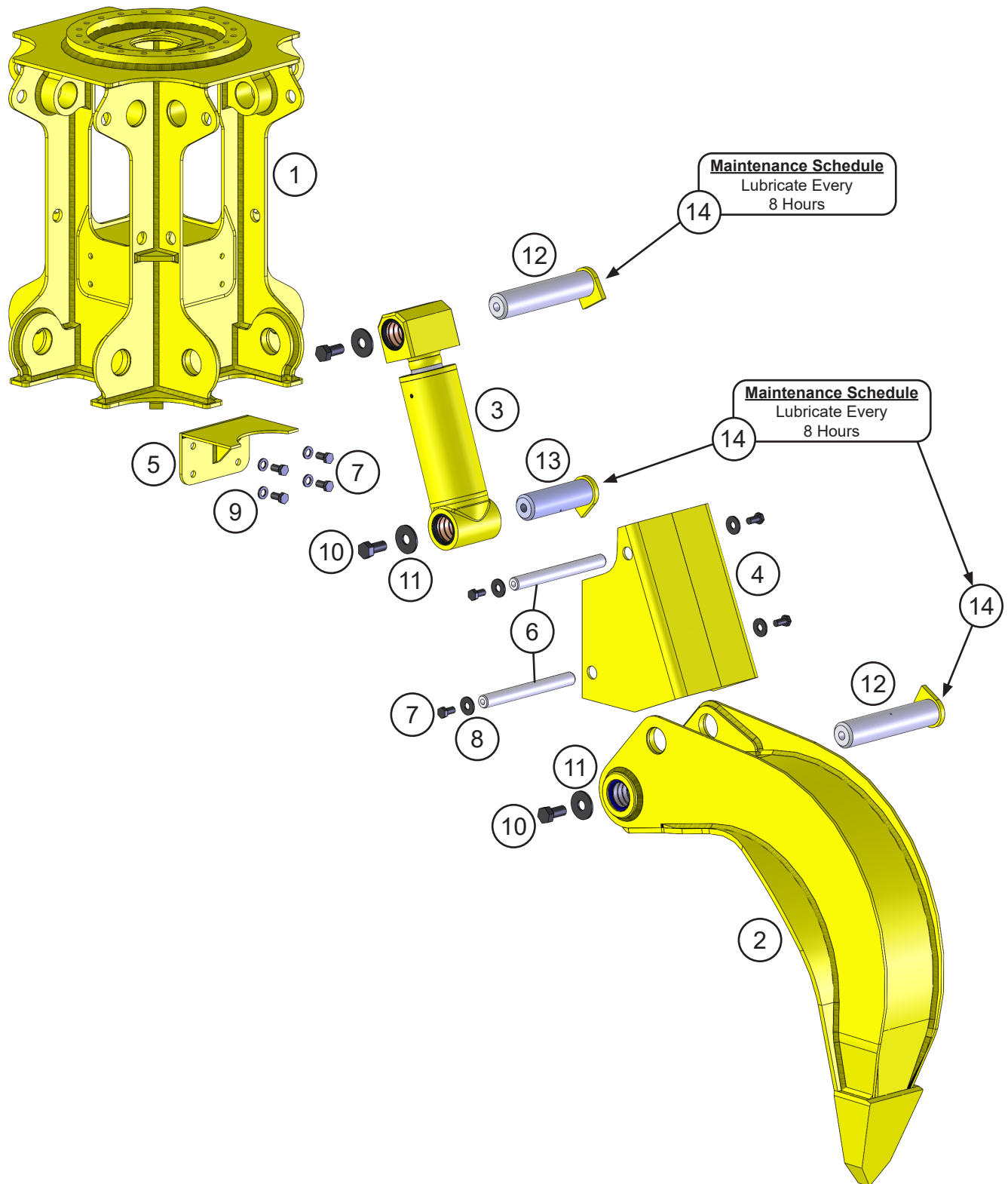

GSG 50/65/75 ASSEMBLY FRAME / TINE

ITEM	QTY	PART NUMBER	DESCRIPTION
1	1	2200608	Wtmg Frame - Light Weight
2	4	2200603	Wtmg Tine Med. Spade - Point - Light Weight - GSG 50
		2200640	Wtmg Tine Med. Spade - Point - Light Weight - GSG 65
		2200602	Wtmg Tine Med. Spade - Point - Light Weight - GSG 75
3	4	6350110	Sub-Assembly Cyl B4.50 x R3.0 x S7.0
4	4	2200600	Wtmg Outer Guard - Light Weight
5	4	2200601	Wtmg Under Guard - Light Weight
6	8	2200221	Mach Guard Mount Bar
7	32	F0116030	Hex Head Capscrew M16 x 2 x 30
8	16	F1310058	Flat Washer Wide .58 x 1.75
9	16	F1201630	Flat Washer M16
10	12	F0124050	Hex Head Capscrew M24 x 2.0 x 50
11	12	2200232	Mach Washer
12	8	2200401	Wldt Pin 2.50 x 11.75
13	4	2200547	Wldt Pin 2.50 x 8.00
14	12	6200002	Grease Fitting 1/8" - 27 NPT

GSG 100/125 ASSEMBLY FRAME / TINE LIGHT WEIGHT

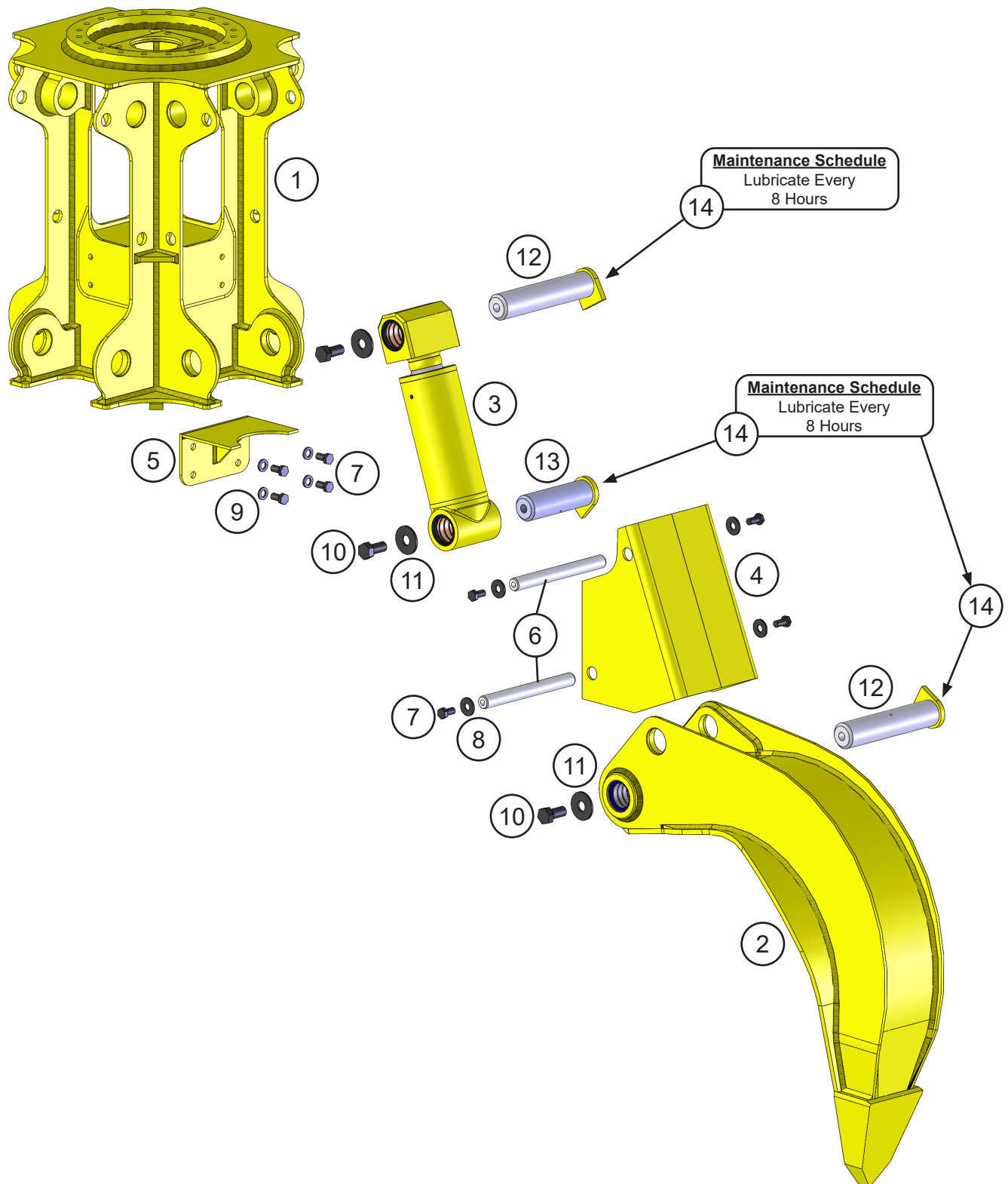

GSG 100/125 ASSEMBLY FRAME / TINE LIGHT WEIGHT

ITEM	QTY	PART NUMBER	DESCRIPTION
1	1	2200499	Wtmg Frame - Light Weight
2	4	2200505	Wtmg Tine Med. Spade - Point - Light Weight - GSG 100
		2200542	Wtmg Tine Med. Spade - Point - Light Weight - GSG 125
3	4	6350108	Sub-Assembly Cyl B4.50 x R3.0 x S8.0
4	4	2200506	Wtmg Outer Guard - Light Weight
5	4	2200504	Wtmg Under Guard - Light Weight
6	8	2200221	Mach Guard Mount Bar
7	32	F0116030	Hex Head Capscrew M16 x 2 x 30
8	16	F1310058	Flat Washer Wide .58 x 1.75
9	16	F1201630	Flat Washer M16
10	12	F0124050	Hex Head Capscrew M24 x 2.0 x 50
11	12	2200232	Mach Washer
12	8	2200401	Wldt Pin 2.50 x 11.75
13	4	2200547	Wldt Pin 2.50 x 8.00
14	12	6200002	Grease Fitting 1/8" - 27 NPT

GSG 100/125 ASSEMBLY FRAME / TINE

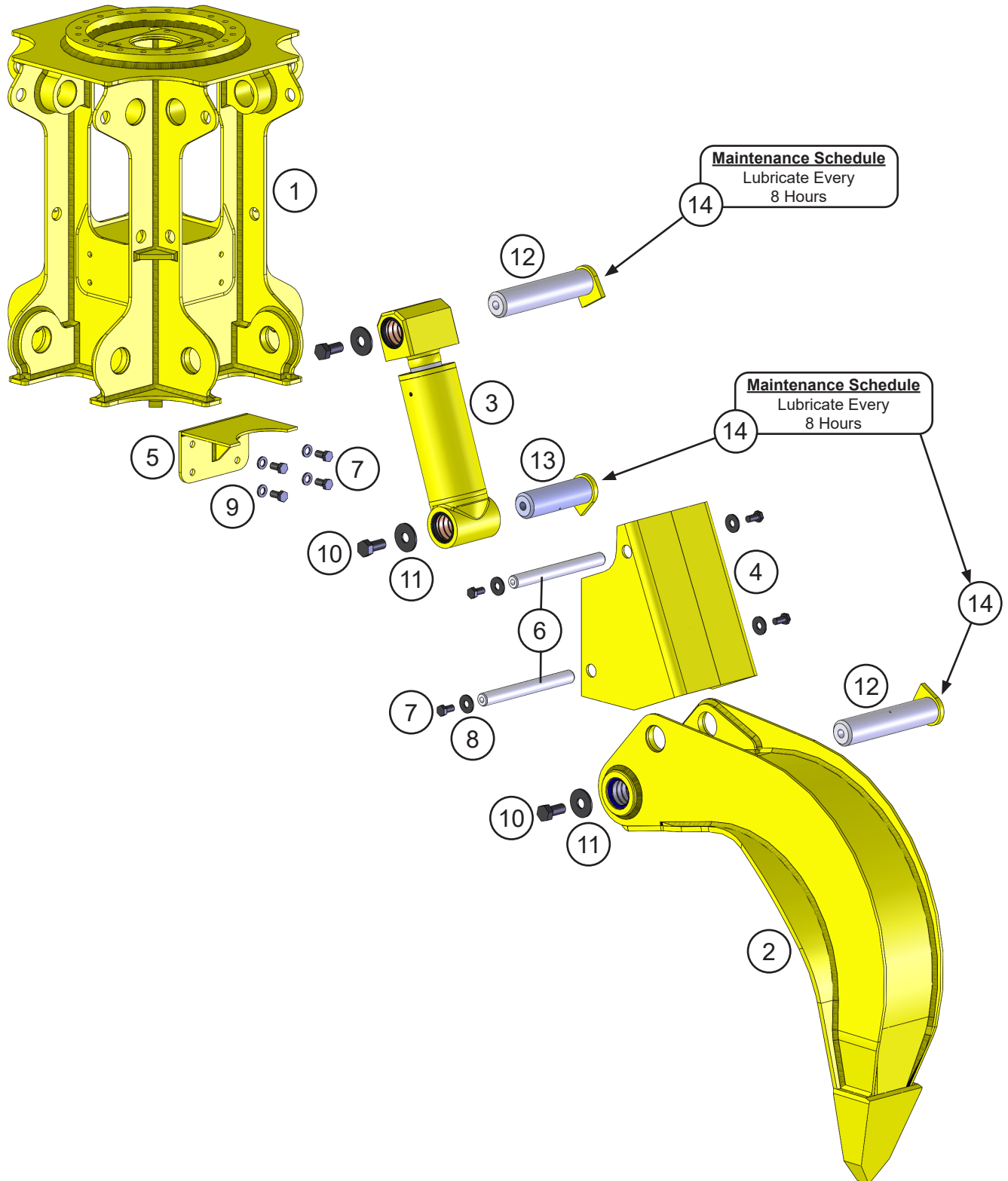

GSG 100/125 ASSEMBLY FRAME / TINE

ITEM	QTY	PART NUMBER	DESCRIPTION
1	1	2200257	Wtmg Frame
2	4	2200457	Wtmg Tine Med. Spade - Point - GSG 100 HD
		2200449	Wtmg Tine Med. Spade - Point - GSG 125 HD
3	4	6350108	Sub-Assembly Cyl B4.50 x R3.0 x S8.0
4	4	2200275	Wtmg Outer Guard
5	4	2200279	Wtmg Under Guard
6	8	2200221	Mach Guard Mount Bar
7	32	F0116030	Hex Head Capscrew M16 x 2 x 30
8	16	F1310058	Flat Washer Wide .58 x 1.75
9	16	F1201630	Flat Washer M16
10	12	F0124050	Hex Head Capscrew M24 x 2.0 x 50
11	12	2200232	Mach Washer
12	8	2200401	Wldt Pin 2.50 x 11.75
13	4	2200404	Wldt Pin 2.50 x 8.13
14	12	6200002	Grease Fitting 1/8" - 27 NPT

GSG 150/200/250 ASSEMBLY FRAME / TINE

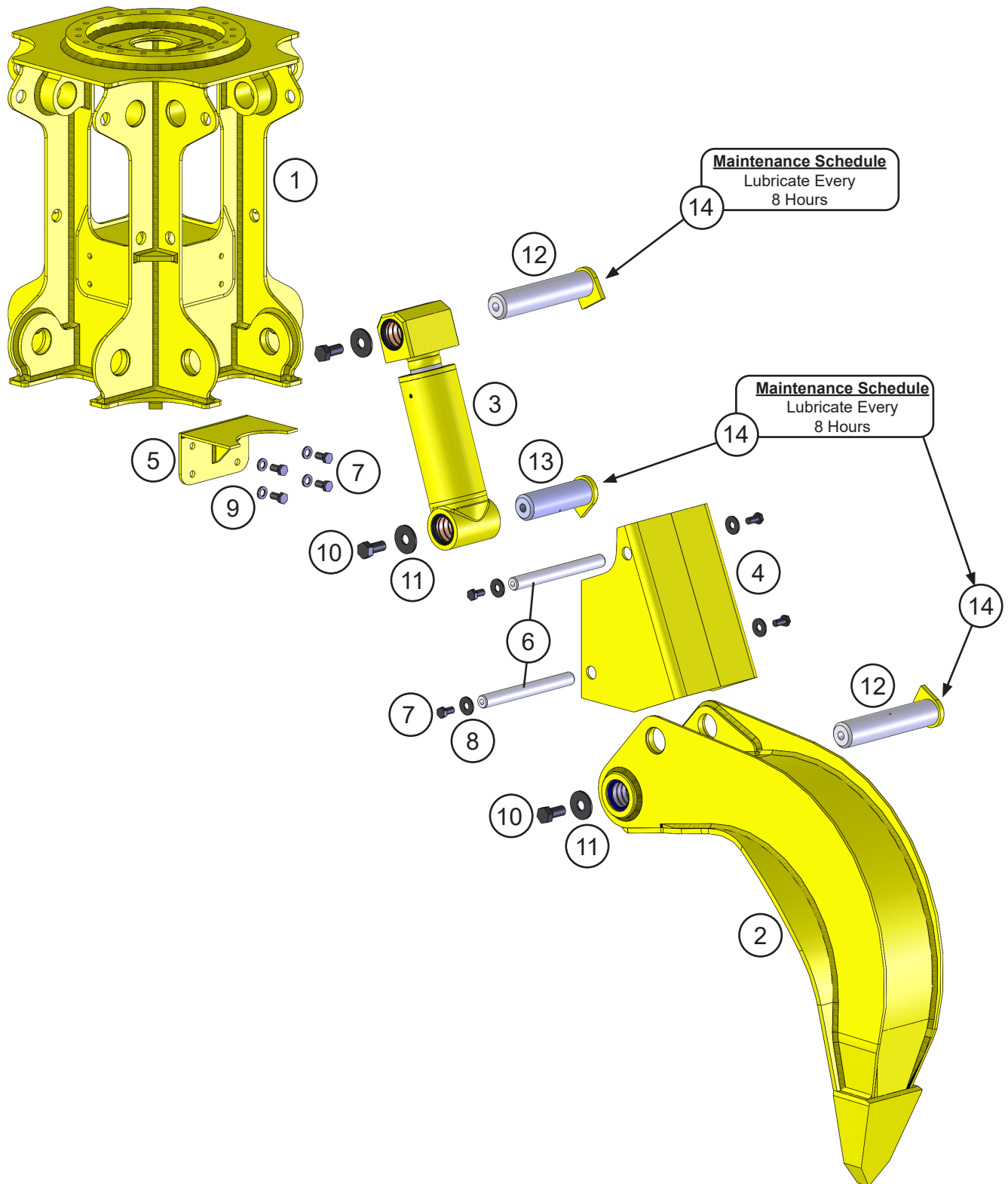

GSG 150/200/250 ASSEMBLY FRAME / TINE

ITEM	QTY	PART NUMBER	DESCRIPTION
1	1	2200235	Wtmg Frame
2	4	2200441	Wtmg Tine Med. Spade - Point - GSG 150
		2200433	Wtmg Tine Med. Spade - Point - GSG 200
		2200426	Wtmg Tine Med. Spade - Point - GSG 250
3	4	6350109	Sub-Assembly Cyl B4.50 x R3.0 x S10.0
4	4	2200246	Wtmg Outer Guard
5	4	2200222	Wtmg Under Guard
6	8	2200221	Mach Guard Mount Bar
7	32	F0116030	Hex Head Capscrew M16 x 2 x 30
8	16	F1310058	Flat Washer Wide .58 x 1.75
9	16	F1201630	Flat Washer M16
10	12	F0124050	Hex Head Capscrew M24 x 2.0 x 50
11	12	2200232	Mach Washer
12	8	2200401	Wldt Pin 2.50 x 11.75
13	4	2200404	Wldt Pin 2.50 x 8.13
14	12	6200002	Grease Fitting 1/8" - 27 NPT

GSG 50/65/75/100/125 ASSEMBLY UPPER HEAD - 2200500

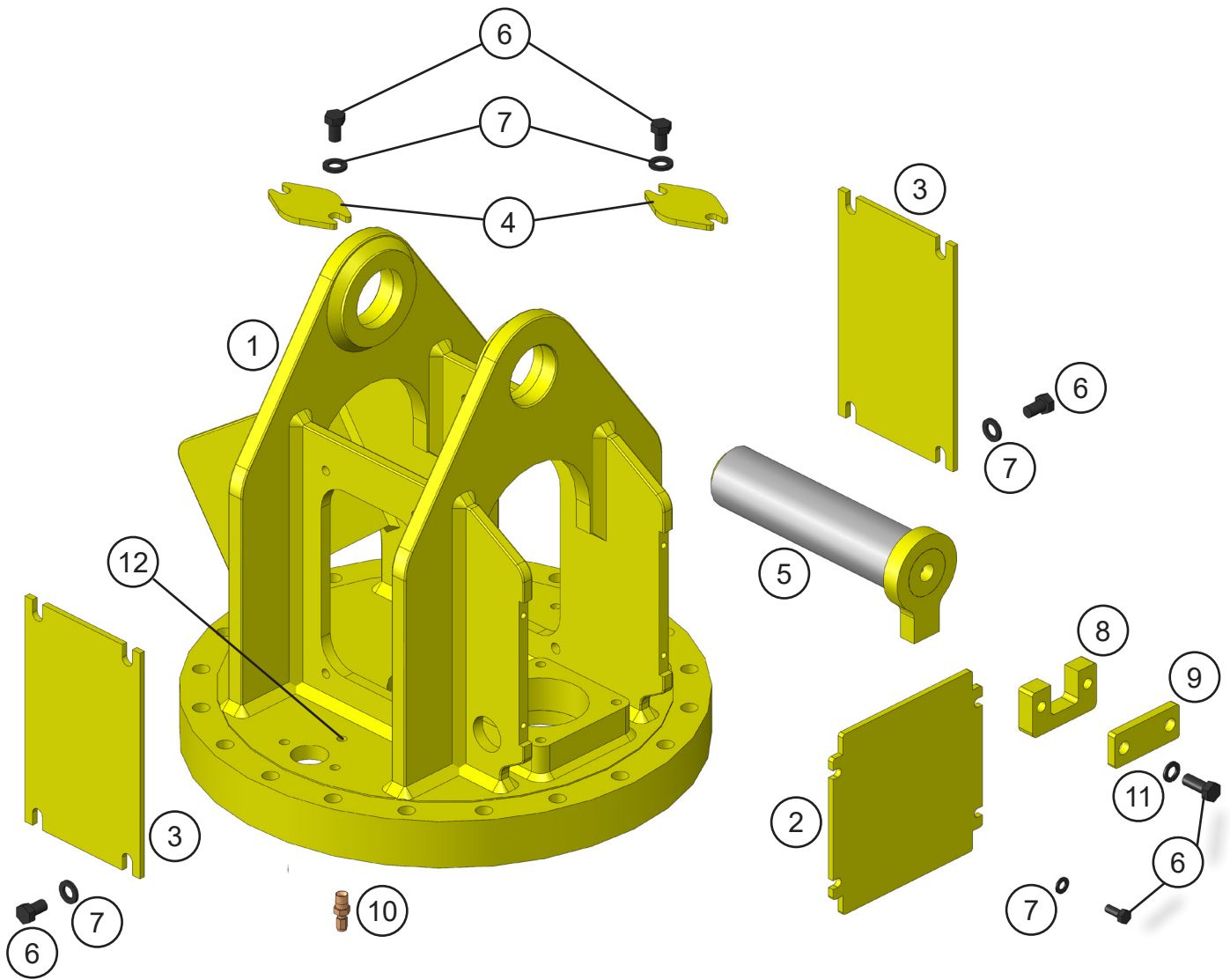

GSG 50/65/75/100/125 ASSEMBLY UPPER HEAD - 2200500

ITEM	QTY	PART NUMBER	DESCRIPTION
1	1	2200291	Wtmg, Head GSG 50/65/75/100/125
2	1	2200298	Plate, End Cover
3	2	2200300	Plate, Side Cover
4	2	2200299	Plate, Bolt Cover
5	1	2200416	Wldt Pin Std
6	18	F0112030	Hex Head Capscrew M12 x 1.75 x 30
7	16	F1201224	Flat Washer M12
8	1	2200304	Mach Pin Keeper
9	4	2200306	Plate Bar Strap
10	1	6300094	Compression Connector
11	2	F1401200	Lock Washer M12
12	1	6200002	Grease Fitting 1/8 - 27 NPT

GSG 150/200/250 ASSEMBLY UPPER HEAD - 2200290

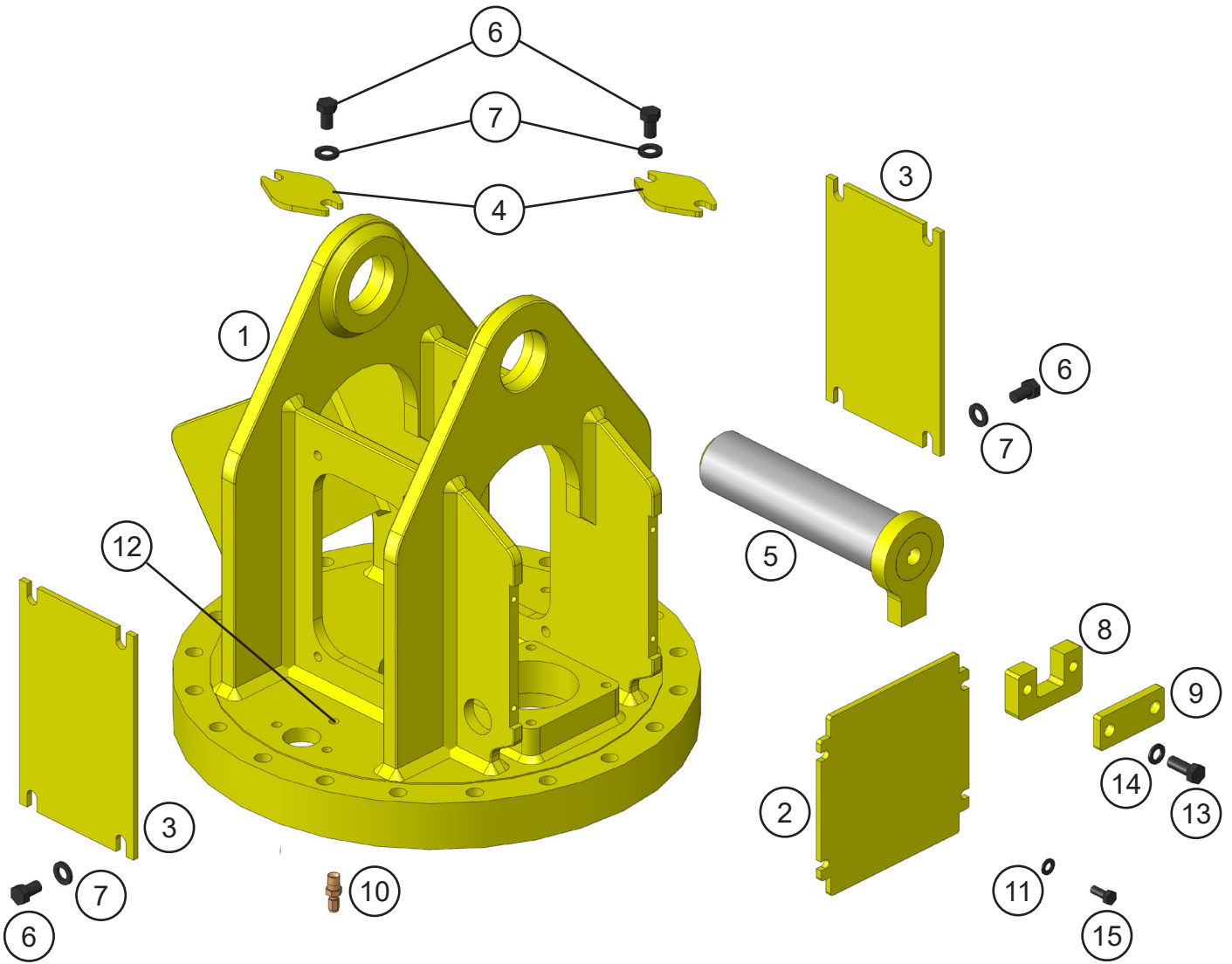

GSG 150/200/250 ASSEMBLY UPPER HEAD - 2200290

ITEM	QTY	PART NUMBER	DESCRIPTION
1	1	2200501	Wtmg, Head GSG 150/200/250
2	2	2200502	Plate, End Cover
3	1	2200503	Plate, Side Cover
4	2	2200610	Plate, Bolt Cover
5	1	2200416	Wldt Pin Std
6	12	F0112020	Hex Head Capscrew M12 x 1.75 x 20
7	12	F1201224	Flat Washer M12
8	1	2200304	Mach Pin Keeper
9	1	2200306	Plate Bar Strap
10	1	6300094	Compression Connector
11	4	F1200817	Flat Washer M8
12	1	6200002	Grease Fitting 1/8 - 27 NPT
13	2	F0112030	Hex Head Capscrew M12 x 1.75 x 30
14	2	F1401200	Lock Washer M12
15	4	F0108030	Hex Head Capscrew M8 x 1.25 x 30

ASSEMBLY ROTATION

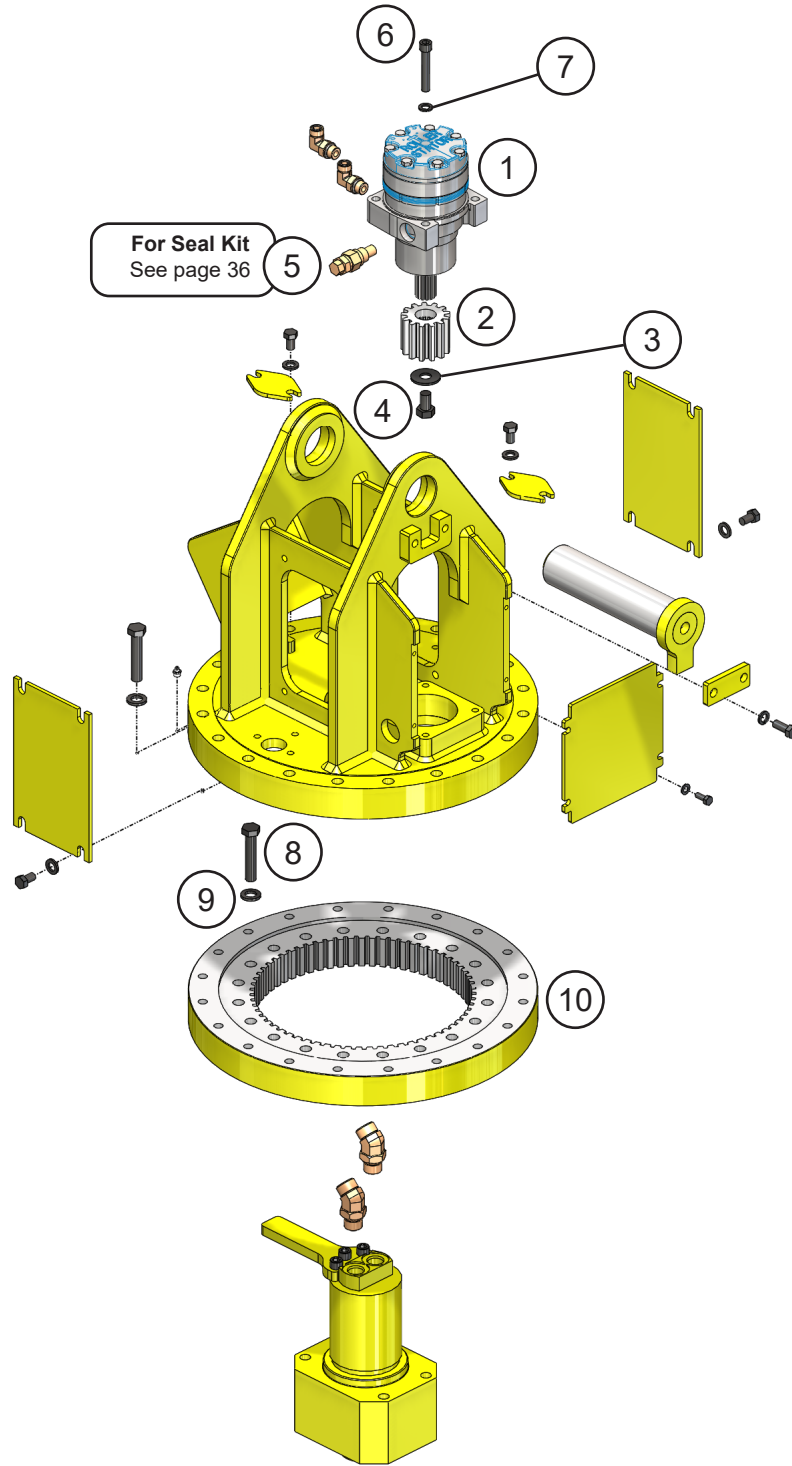

ASSEMBLY ROTATION

ITEM	QTY	PART NUMBER	DESCRIPTION
1	1	6340010	Hydraulic Motor
2	1	6300901	Pinion
3	1	F1317563	Flat Washer
4	1	F0263100	Hex Head Capscrew $\frac{5}{8}$ - 18 x 1
5	1	6300902	Cartridge - Crossport Relief
6	4	F0612070	Socket Head Capscrew M12 x 1.75 x 70
7	4	F1401200	Lock Washer M12
8	40	F0116080	Hex Head Capscrew M16 x 2 x 80
9	40	F1201630	Flat Washer M16
10	1	6300900	Slewing Ring

GSG 50/65/75 ASSEMBLY CYLINDER - 6350091

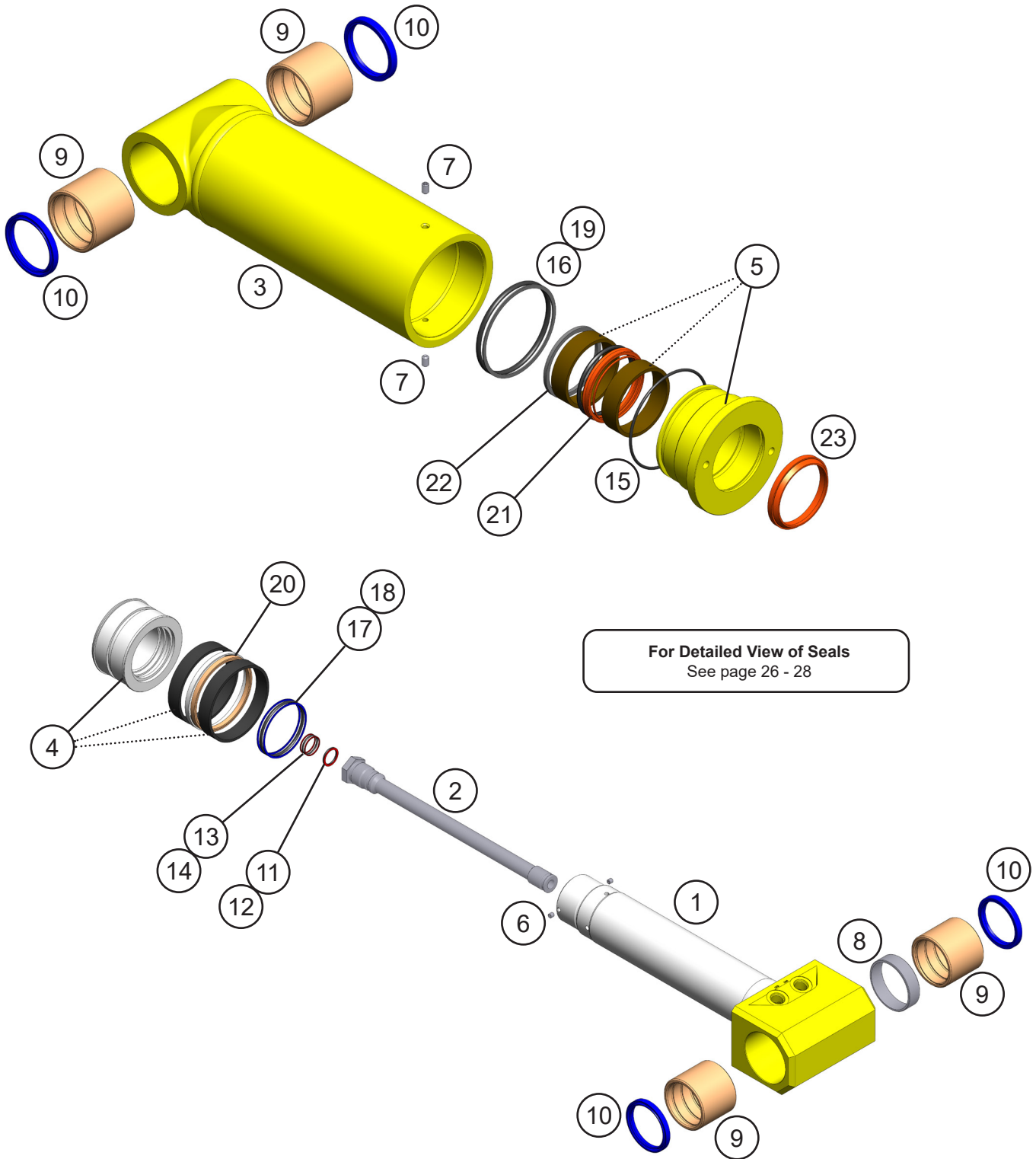

For Detailed View of Seals
See page 26 - 28

Basic Cylinder Specs
B4.5 R3.0 S7.0

GSG 50/65/75 ASSEMBLY CYLINDER - 6350091

ITEM	QTY	PART NUMBER	DESCRIPTION
1	1	For replacement parts call the Genesis Parts Department. USA 715-395-3488 Europe +49 83 31 9 25 98 0	Piston Tube Assembly
2	1		Manifold Tube Assembly
3	1		Butt and Tube Assembly
4	1		Unitized Piston
5	1		Unitized Gland
6	2		Set Screw 1/4 - 20
7	2		Set Screw 5/16 - 18
8	1		Steel Spacer
9	4		Steel Bushing
10	4		Pin Wiper
11	1		O-Ring
12	1		BU-Wiper
13	1		O-Ring
14	2		BU-Wiper
15	1		O-Ring
16	1		O-Ring
17	1		O-Ring
18	1		BU-Wiper
19	1		BU-Wiper
20	1		Piston Seal
21	1		Rod Seal
22	1		Buffer Seal / Prac Seal
23	1		Wiper

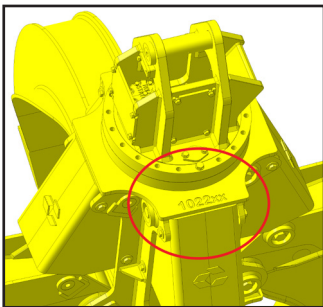

GSG Serial
Number Location

GSG 100/125 ASSEMBLY CYLINDER - 6350071

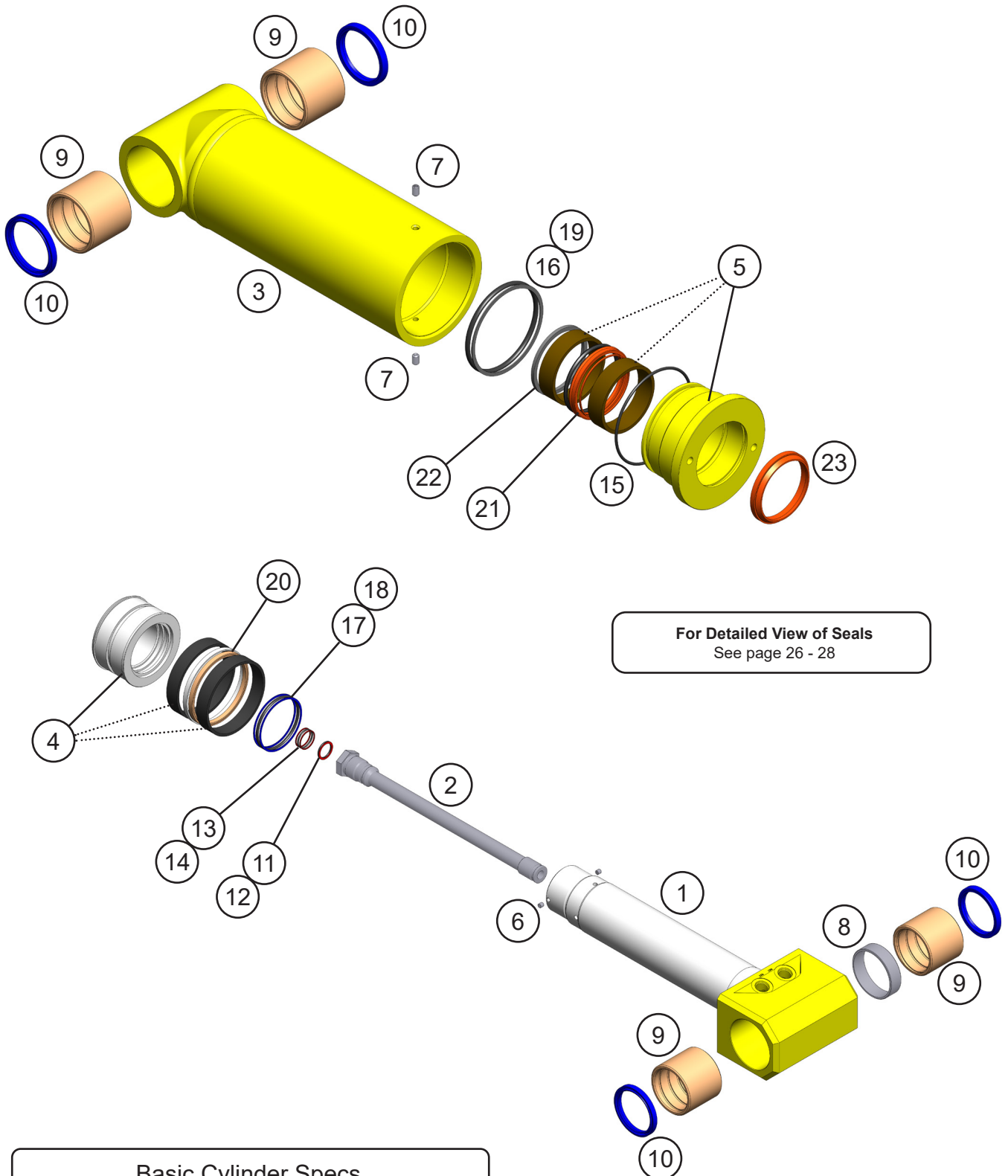

For Detailed View of Seals
See page 26 - 28

Basic Cylinder Specs
B4.5 R3.0 S8.0

GSG 100/125 ASSEMBLY CYLINDER - 6350071

ITEM	QTY	PART NUMBER	DESCRIPTION
1	1	For replacement parts call the Genesis Parts Department. USA 715-395-3488 Europe +49 83 31 9 25 98 0	Piston Tube Assembly
2	1		Manifold Tube Assembly
3	1		Butt and Tube Assembly
4	1		Unitized Piston
5	1		Unitized Gland
6	2		Set Screw 1/4 - 20
7	2		Set Screw 5/16 - 18
8	1		Steel Spacer
9	4		Steel Bushing
10	4		Pin Wiper
11	1		O-Ring
12	1		BU-Wiper
13	1		O-Ring
14	2		BU-Wiper
15	1		O-Ring
16	1		O-Ring
17	1		O-Ring
18	1		BU-Wiper
19	1		BU-Wiper
20	1		Piston Seal
21	1		Rod Seal
22	1		Buffer Seal / Prac Seal
23	1		Wiper

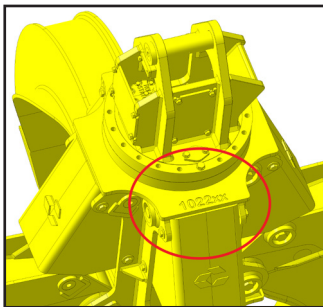

GSG Serial Number Location

GSG 150/200/250 ASSEMBLY CYLINDER - 6350072

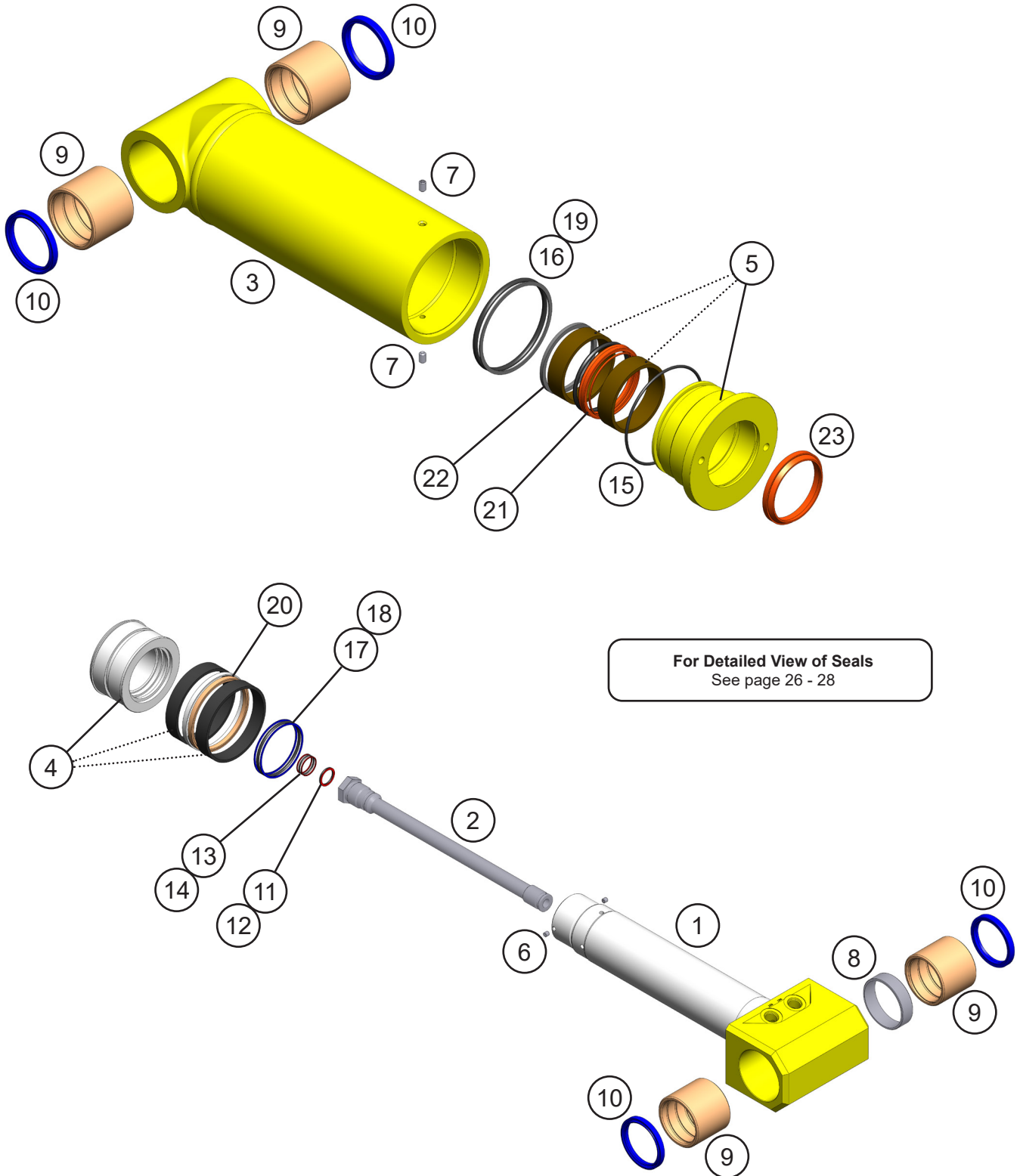

For Detailed View of Seals
See page 26 - 28

Basic Cylinder Specs
B4.5 R3.0 S10.0

GSG 150/200/250 ASSEMBLY CYLINDER - 6350072

ITEM	QTY	PART NUMBER	DESCRIPTION
1	1	For replacement parts call the Genesis Parts Department. USA 715-395-3488 Europe +49 83 31 9 25 98 0	Piston Tube Assembly
2	1		Manifold Tube Assembly
3	1		Butt and Tube Assembly
4	1		Unitized Piston
5	1		Unitized Gland
6	2		Set Screw 1/4 - 20
7	2		Set Screw 5/16 - 18
8	1		Steel Spacer
9	4		Steel Bushing
10	4		Pin Wiper
11	1		O-Ring
12	1		BU-Wiper
13	1		O-Ring
14	2		BU-Wiper
15	1		O-Ring
16	1		O-Ring
17	1		O-Ring
18	1		BU-Wiper
19	1		BU-Wiper
20	1		Piston Seal
21	1		Rod Seal
22	1		Buffer Seal / Prac Seal
23	1		Wiper

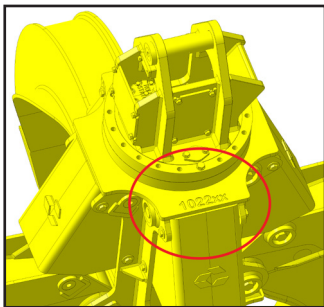

GSG Serial Number Location

ASSEMBLY GLAND SEALS

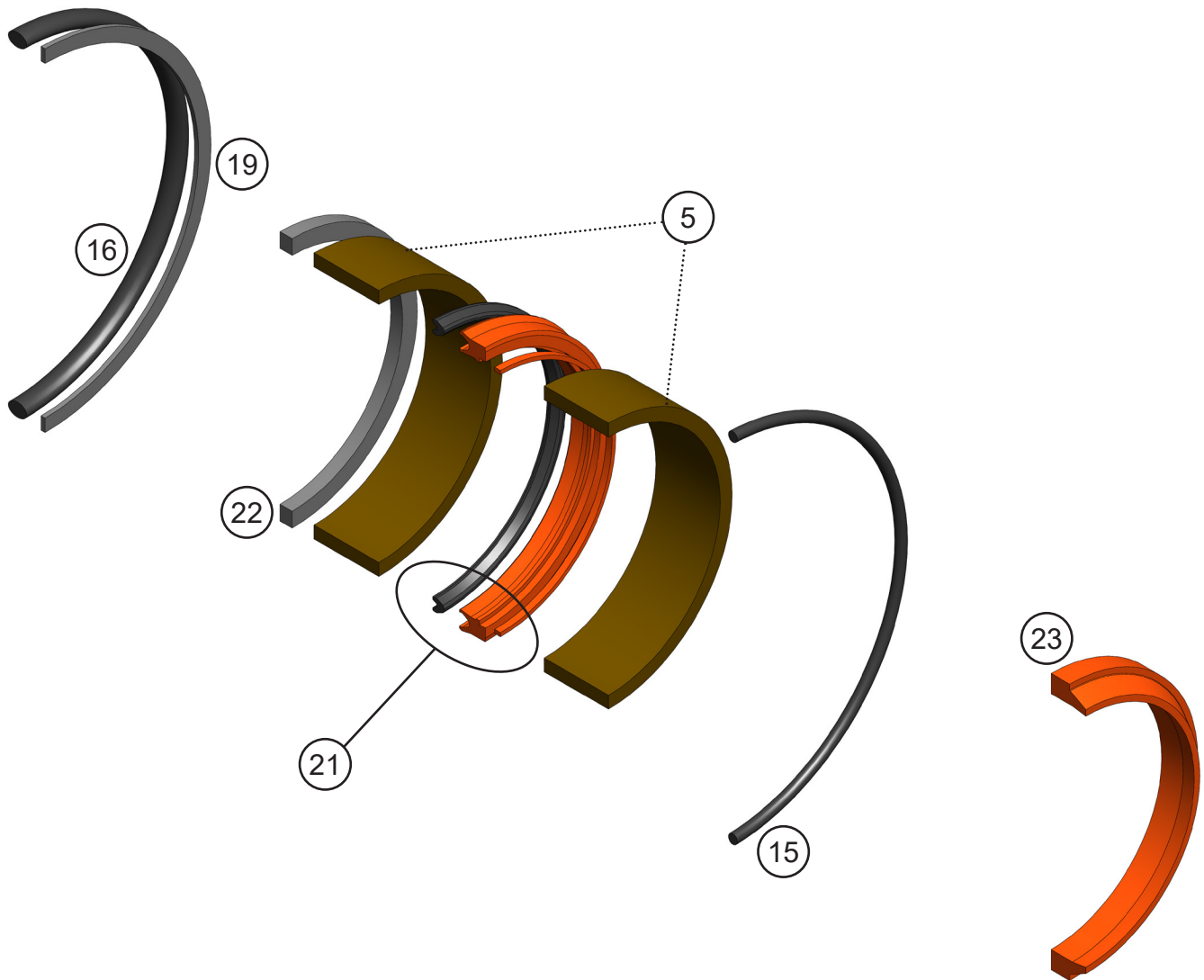

ASSEMBLY GLAND SEALS

ITEM	QTY	PART NUMBER	DESCRIPTION
5	1	For replacement parts call the Genesis Parts Department. USA 715-395-3488 Europe +49 83 31 9 25 98 0	Unitized Gland
15	1		O-Ring
16	1		O-Ring
19	1		BU-Wiper
21	1		Rod Seal
22	1		Buffer Seal / Prac Seal
23	1		Wiper

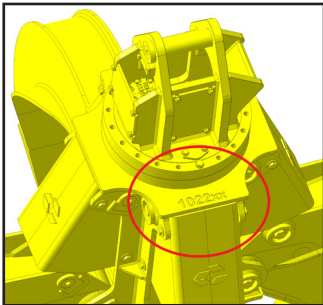

GSG Serial
Number Location

ASSEMBLY PISTON SEALS

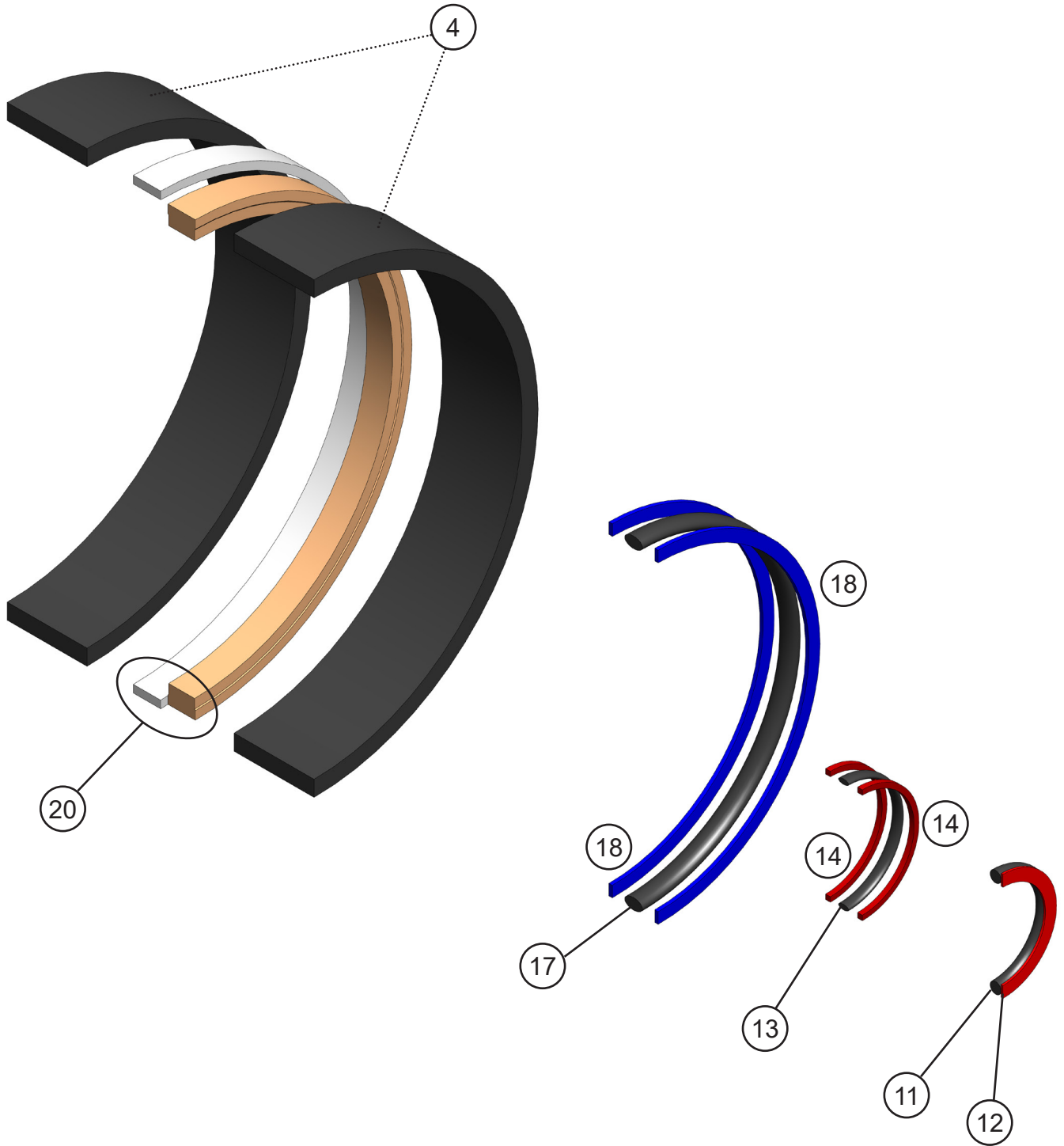

ASSEMBLY PISTON SEALS

ITEM	QTY	PART NUMBER	DESCRIPTION
4	1	For replacement parts call the Genesis Parts Department. USA 715-395-3488 Europe +49 83 31 9 25 98 0	Unitized Piston
11	1		O-Ring
12	1		BU-Wiper
13	1		O-Ring
14	2		BU-Wiper
17	1		O-Ring
18	2		BU-Wiper
20	1		Piston Seal

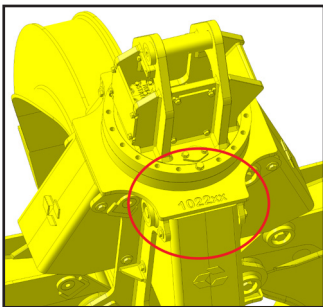

GSG Serial
Number Location

ASSEMBLY SWIVEL - 6350089

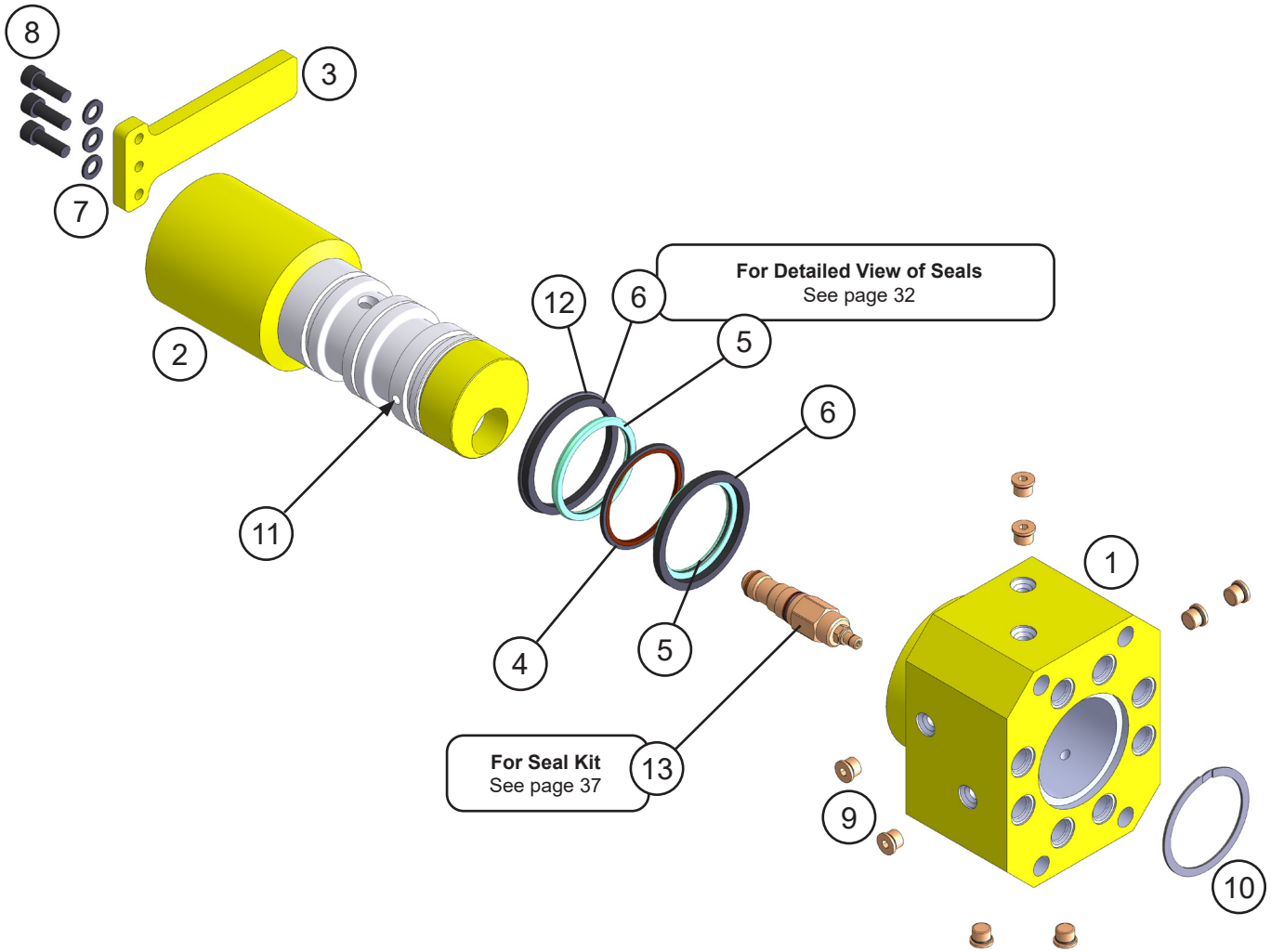

ASSEMBLY SWIVEL - 6350089

ITEM	QTY	PART NUMBER	DESCRIPTION
1	1	For replacement parts call the Genesis Parts Department. USA 715-395-3488 Europe +49 83 31 9 25 98 0	8-Port Housing
2	1		2-Port Spool
3	1		Torque Arm
4	1		Seal Kit
5	2		Crown Seal
6	2		Wear Ring
7	3		Lockwasher M10
8	3		Socket Head Capscrew M10 x 1.50 x 30
9	8		#6 SAE Plug
10	1		Retaining Ring
11	1		1/8 NPT Plug
12	1		O-Ring
13	1	6300817	Cartridge - Relief

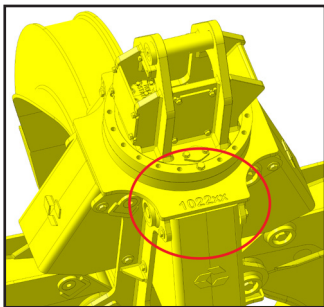

GSG Serial
Number Location

ASSEMBLY SWIVEL SEALS - DETAILED VIEW

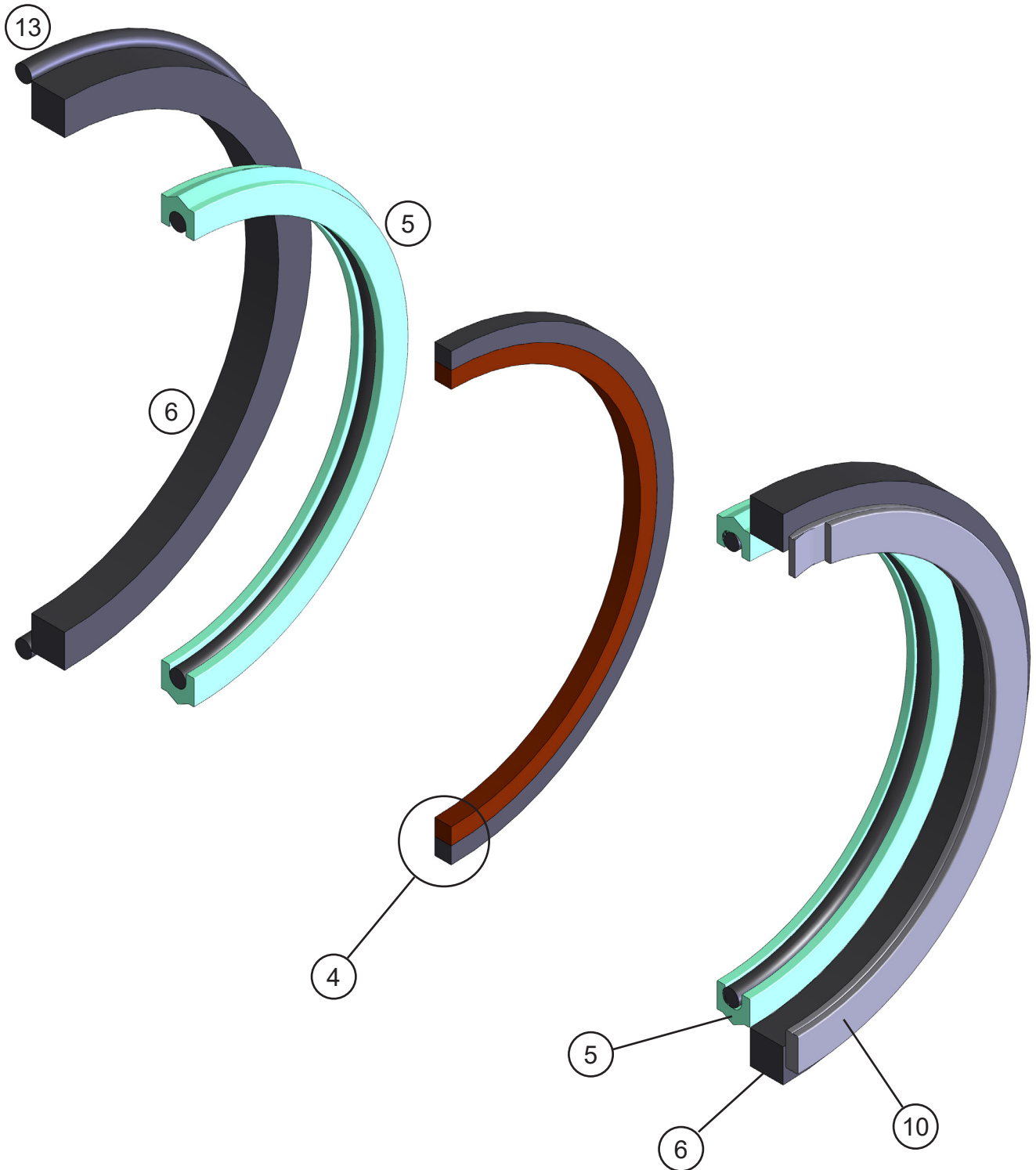

ASSEMBLY SWIVEL SEALS - DETAILED VIEW

ITEM	QTY	PART NUMBER	DESCRIPTION
4	1	For replacement parts call the Genesis Parts Department. USA 715-395-3488 Europe +49 83 31 9 25 98 0	Seal Kit
5	2		Crown Seal
6	2		Wear Ring
10	1		Retaining Ring
13	1		O-Ring

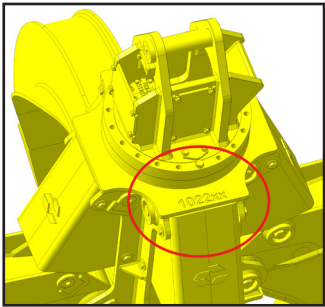

GSG Serial
Number Location

ASSEMBLY HYDRAULIC

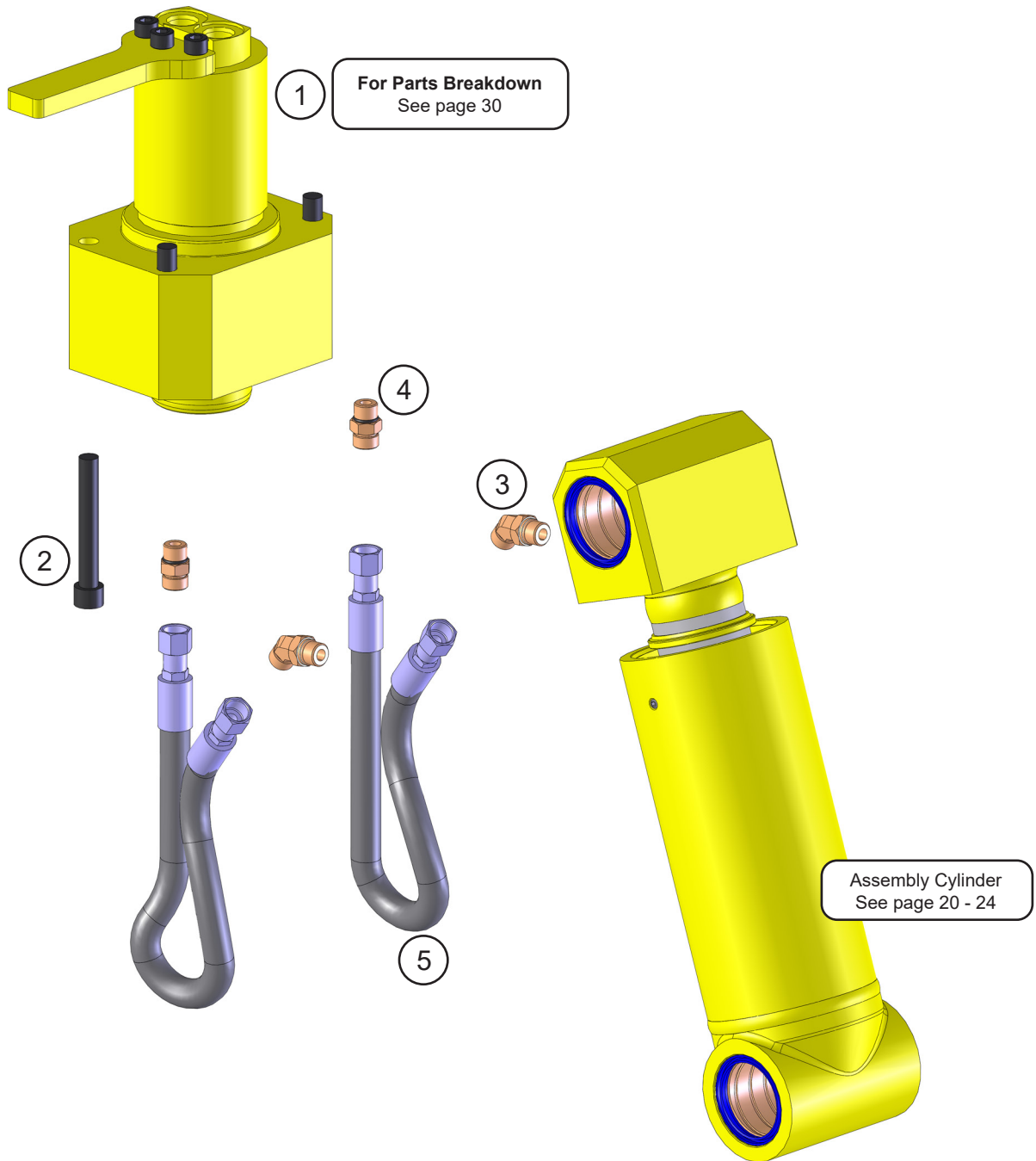

ASSEMBLY HYDRAULIC

ITEM	QTY	PART NUMBER	DESCRIPTION
1	1	See page 30	Assembly Swivel
2	4	F0616110	Socket Head Capscrew M16 x 2.0 x 110
3	8	6300302	Adaptor - 08MB-08MO-45
4	8	6300149	Adaptor - 10MB-08MO
5	8	5300449	Hose

CARTRIDGE, CROSSPORT RELIEF - 6300902

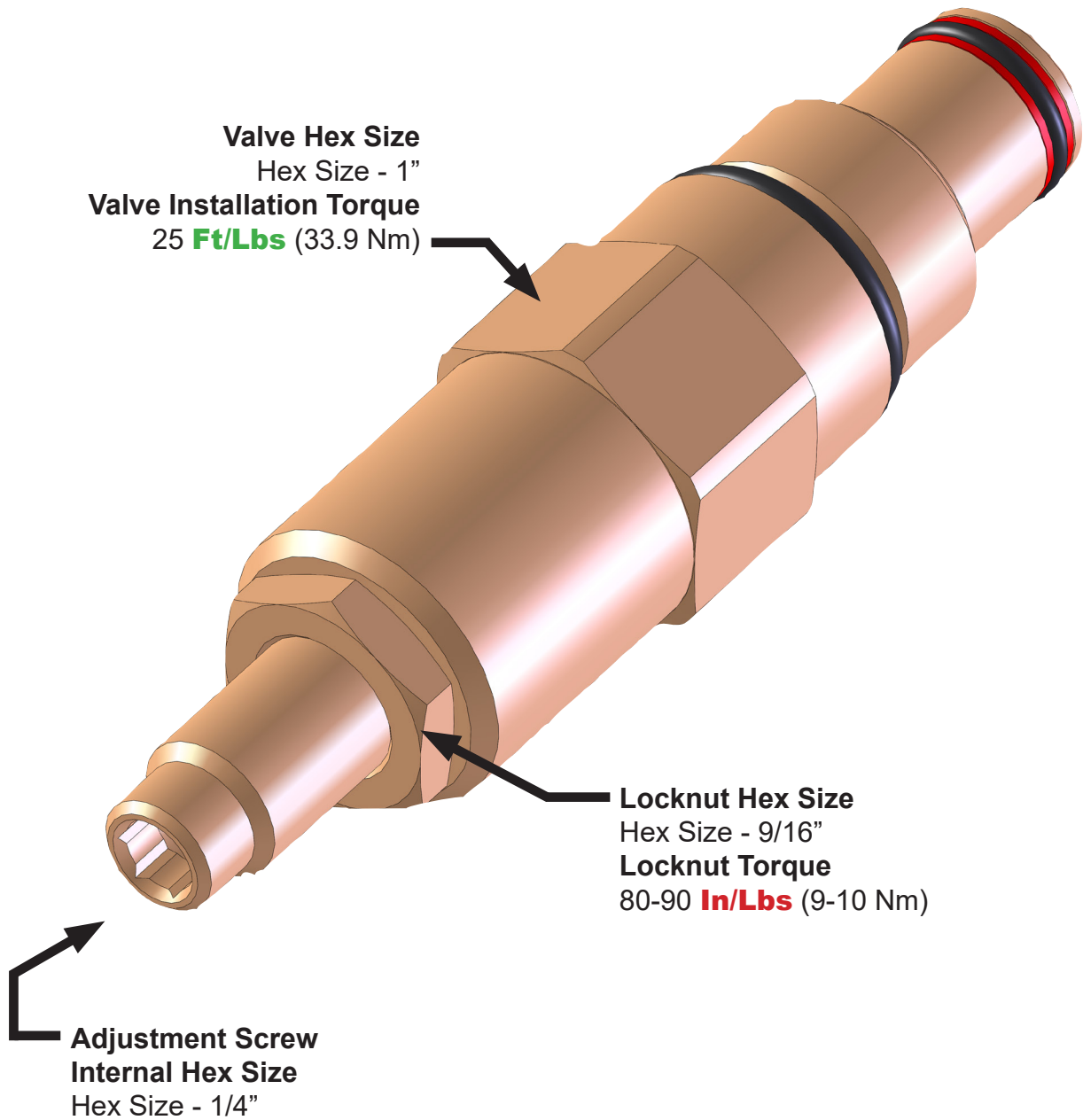

SK00135
Seal Kit

CARTRIDGE, CROSSPORT RELIEF - 6300817

Valve Hex Size
Hex Size - 1-1/8"
Valve Installation Torque
45-50 **Ft/Lbs** (61-68 Nm)

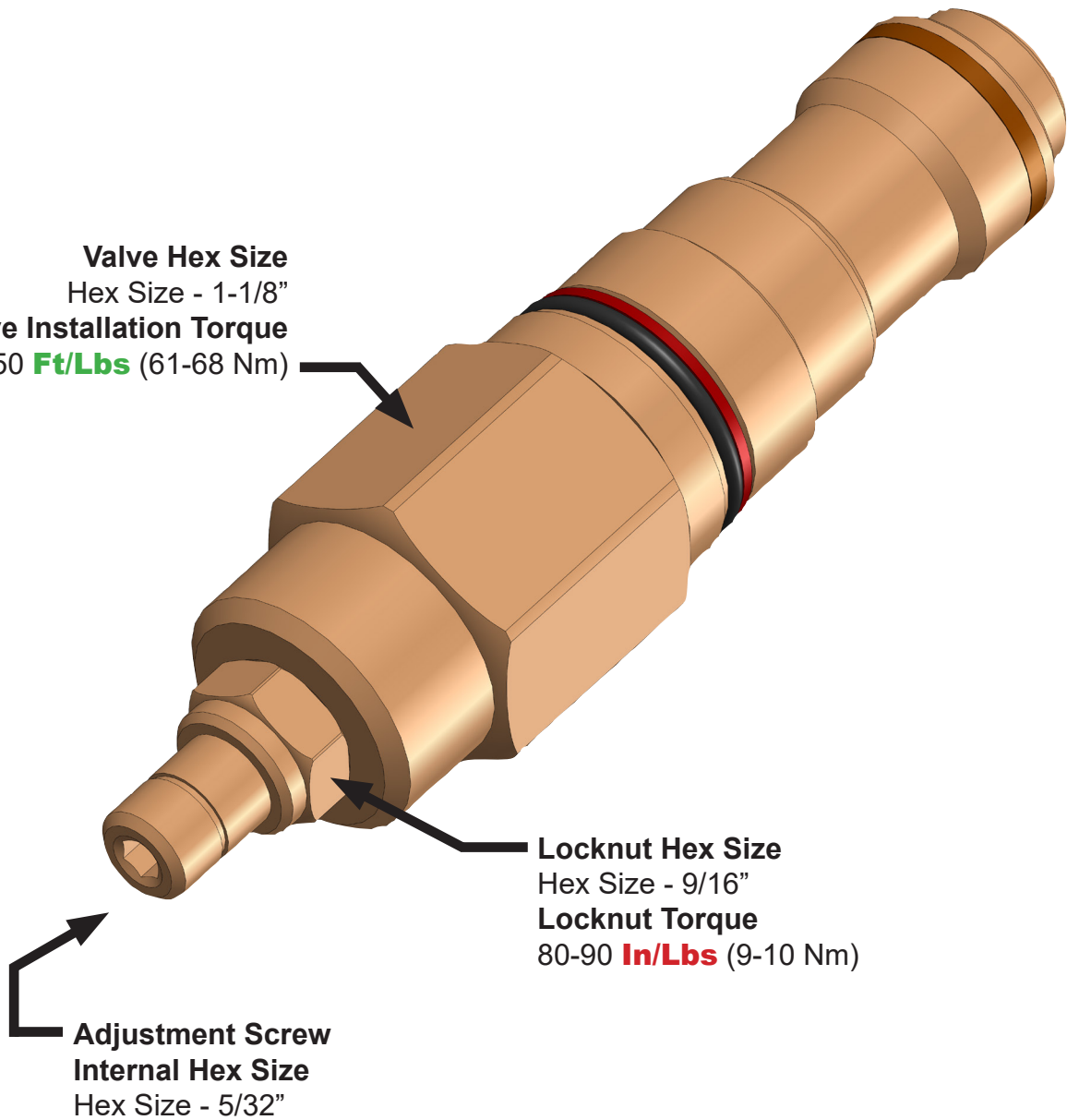

6300634
Seal Kit

ASSEMBLY YOKE (FORKED STICK)

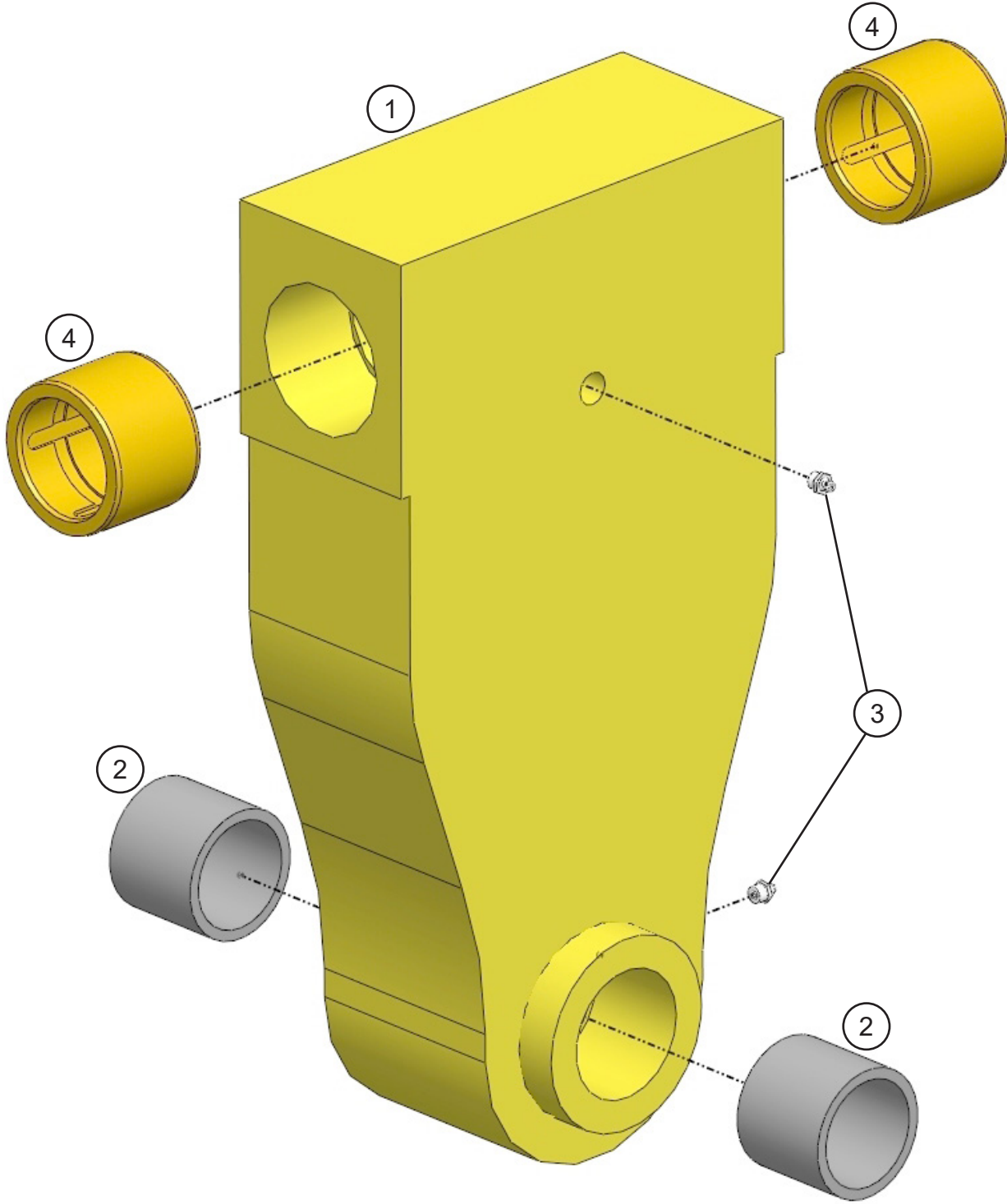

ASSEMBLY YOKE (FORKED STICK)

ITEM	QTY	PART NUMBER	DESCRIPTION
1	1	See Below	Wtmg Yoke
2	2		Mach Bearing
3	2		Grease Fitting
4	2		Mach Bearing

Part Numbers are Serial Number specific. For replacement parts call the Genesis Parts Department.

USA
715-395-3488

Europe
+49 83 31 9 25 98 0

ASSEMBLY YOKE

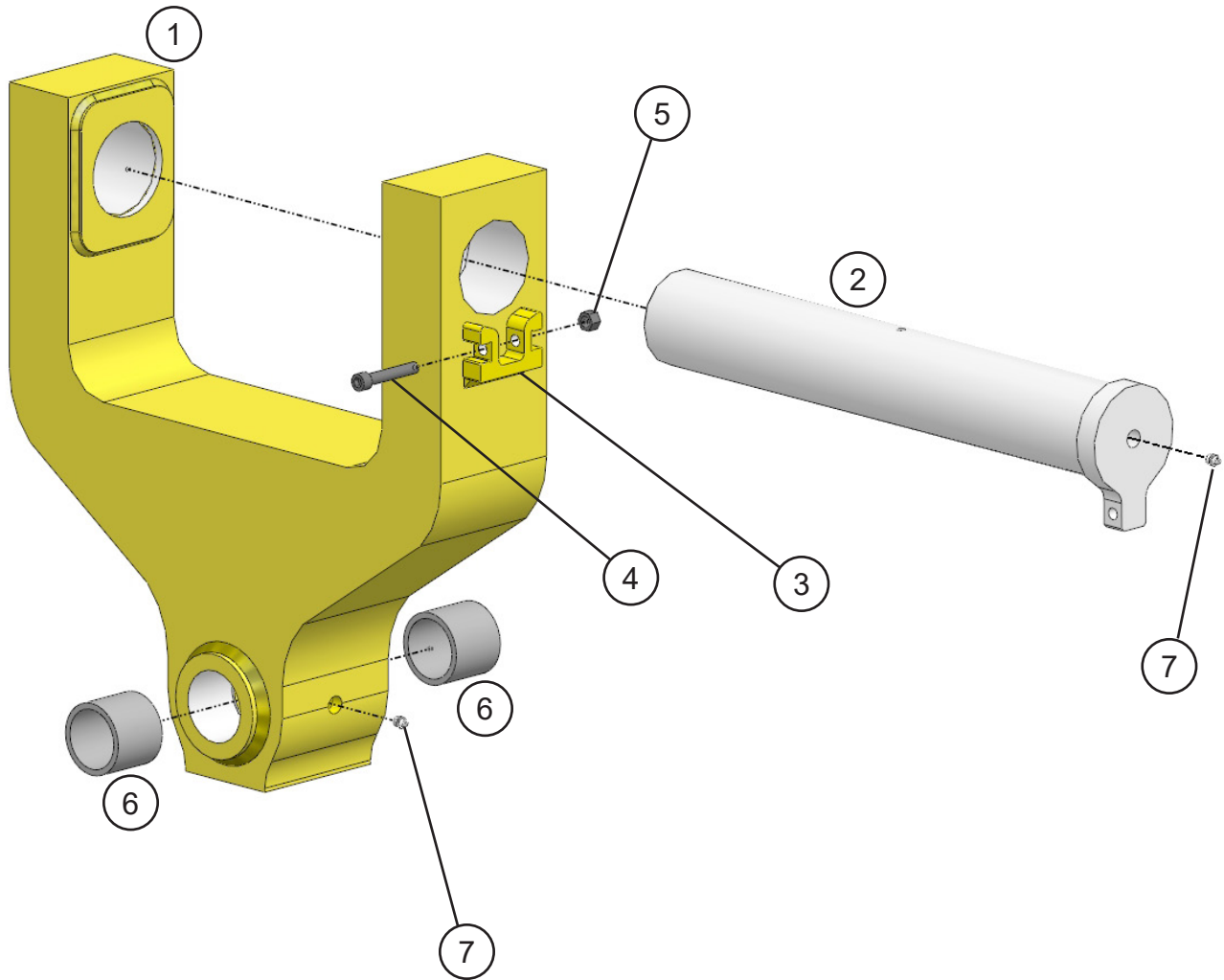

ASSEMBLY YOKE

ITEM	QTY	PART NUMBER	DESCRIPTION
1	1	Part Numbers are Serial Number specific. For replacement parts call the Genesis Parts Department USA 715-395-3488 Europe +49 83 31 9 25 98 0	Wtmg Yoke
2	2		Wldt Pin Drill
3	2		Mach Pin Keeper
4	2		Socket Head Capscrew
5	2		Nylock Hex Head
6	2		Mach Bearing and Seal
7	2		Grease Fitting

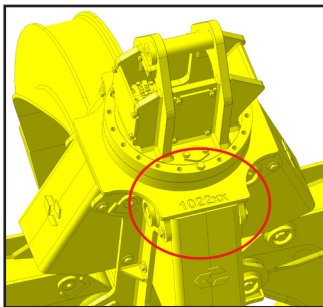

GSG Serial Number Location

BOLT TORQUE SPECIFICATIONS

Reference the product Thread Treatment Diagrams on page 43 to determine whether to use wet or dry torque values for specific bolts.

Reference Procedures on page 44 for threadlocker or anti-seize application and bolt and bolt hole cleaning.

Prior to torquing, clean all bolt holes, bolts and nuts to remove dirt, grease and oil, and identify bolt type.

Never re-torque bolts that use Loctite. If a bolt becomes loose or damaged after the initial use when Loctite was applied and the bolt was torqued, the bolt must be replaced.

Never break tightened bolts loose with a torque wrench. Doing so may break the torque wrench or take it out of calibration.

Torque wrenches should be calibrated on an annual basis.

When using a torque multiplier with a torque wrench, incorrect settings will be multiplied by the ratio of the torque wrench.

Never use an impact driver on a torque multiplier.

THREAD TREATMENT DIAGRAM

Grapples

Use this diagram to determine what thread treatment, if any, is required for each fastener.

For thread treatment application procedures, see page 44. For prescribed torque values, see page 46.

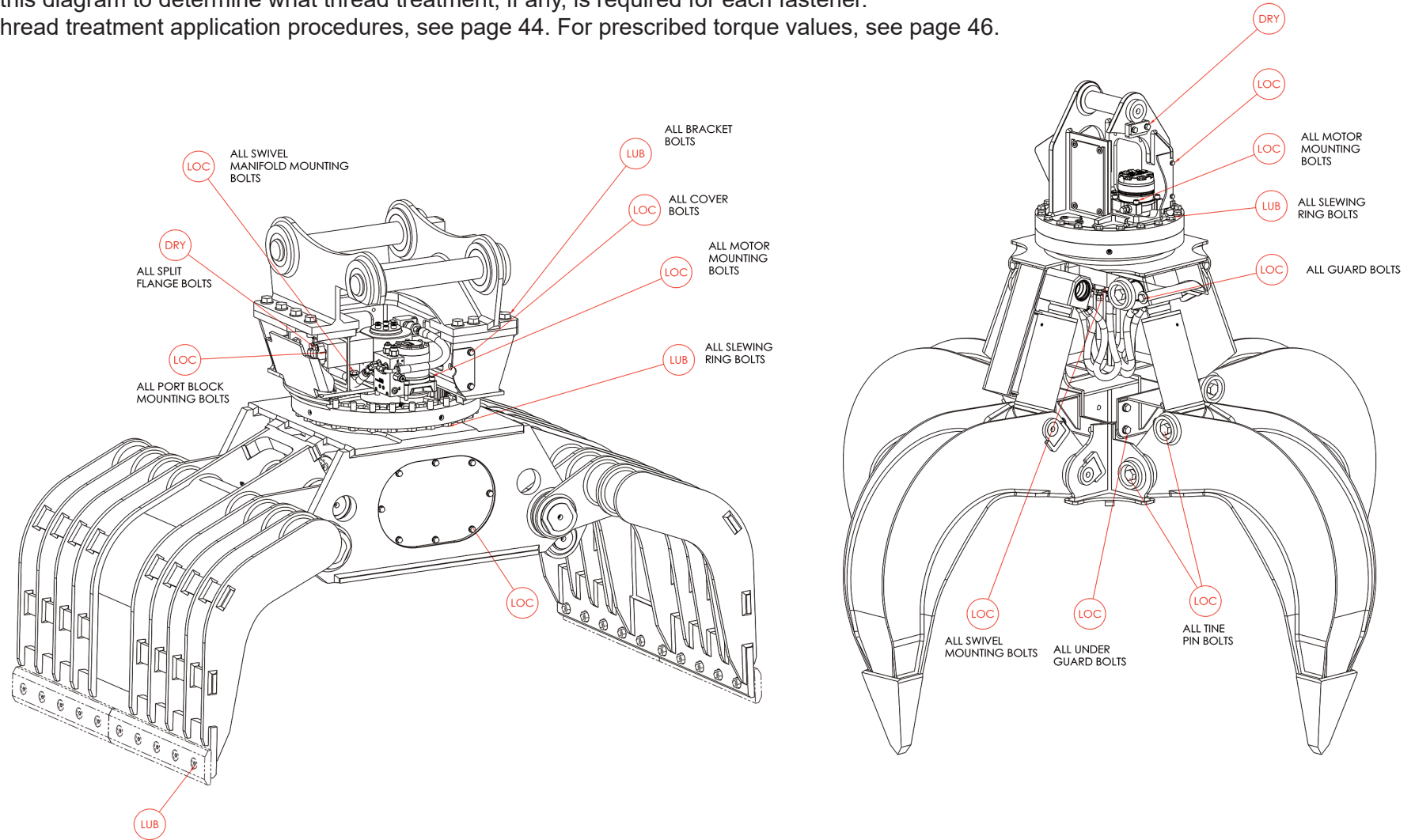

PROCEDURES

Reference the product Thread Treatment Diagrams on page 43 to determine which of the following procedures is required.

Cleaning

To ensure proper performance of thread treatment and accurate torque values, clean and degrease **all internal and external threads** prior to application of threadlocker, anti-seize or primer and before installation of hardware.

- Ensure both internal and external threads are free of dirt or debris.
- Use brake cleaner or similar cleaning solvent on all threads to remove any grease or oil.
- Allow threads to dry.

NOTICE

Failure to properly clean threads will cause threadlocker, primer, and/or anti-seize to not properly cure!

LOC

Threadlocker

For bolted connections requiring threadlocker, use **Loctite 263** or equivalent applied using the following procedure:

- Clean and degrease all threads.
- For thru holes or nuts, apply threadlocker to bolt threads.
- For blind holes, apply stripe of threadlocker along the length of the hole (applying to the bolt can cause escaping air to remove threadlocker as the bolt is inserted).
- Torque bolt to specified **Wet Torque Value**, see page 46.

For threaded hydraulic fitting connections, use **Loctite 5452** or equivalent thread sealant in conjunction with **Loctite 7471** primer using the following procedure:

- Clean and degrease all threads.
- Apply Loctite 7471 primer to both external and internal threads and allow to dry.
- Apply threadlocker to 360 degrees of the threads on the male fitting, ensuring adequate coverage.
- Assemble fitting per directions in operator's manual.
- For O-ring boss and flat face O-ring connections, torque fittings to values specified on page 47.

Threadlocker

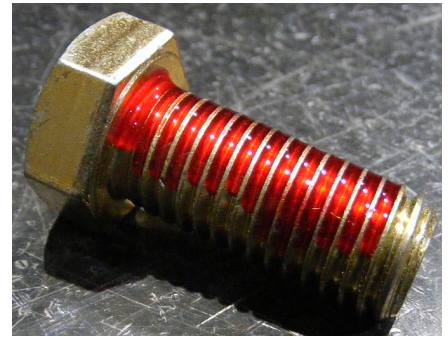

Blind Hole

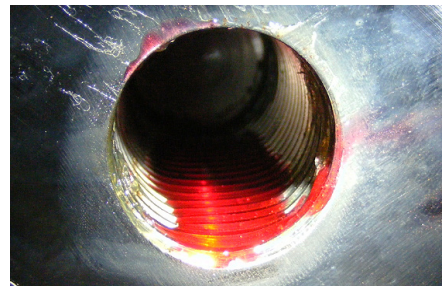

Hydraulic Fitting



PROCEDURES

LUB

Anti-Seize

For bolted connections requiring anti-seize lubrication, use **Loctite LB8008** or equivalent using the following procedure:

- Clean and degrease all threads.
- Apply thin coat of anti-seize to internal and external threads and under bolt head and/or nut, ensuring complete coverage.
- Torque bolt to specified **Wet Torque Value**, see page 46.

Anti-Seize









DRY

No Thread Treatment

- Clean and degrease all threads.
- Torque bolt to specified **Dry Torque Value**, see page 46.

BOLT TORQUE SPECIFICATIONS

Dry Torque Values					
		Hex/Socket Head		Flat Head	
		 			
Fastener Grade	Size x Pitch	Nm	Ft-lb	Nm	Ft-lb
CL 10.9	M8 x 1.25	35	26	27	20
	M10 x 1.50	71	53	58	42
	M12 x 1.75	124	92	101	73
	M14 x 1.50	200	148	163	118
	M14 x 2.00	200	148	163	118
	M16 x 2.00	311	230	254	184
	M20 x 1.50	610	450	498	360
	M20 x 2.50	608	449	497	359
	M24 x 3.00	1054	778	861	622
	M27 x 3.00	1543	1138	1260	910
	M30 x 3.50	2095	1545	1712	1236
	M36 x 4.00	3659	2699	2991	2159
8	1/4-20	14	11	11	8
	5/16-18	32	24	26	19
	3/8-16	59	44	48	35
	7/16-14	94	70	77	56
	1/2-13	143	106	116	84
	1/2-20	162	120	133	96
	5/8-11	287	212	234	169
	3/4-10	509	376	415	300
	7/8-9	821	606	670	484
	1.00-8	1232	909	1007	727
	1.00-14	1383	1020	1130	816
	1.25-7	2463	1817	2013	1453
8/L9	1.50-6	4287	3162	3504	2529

Wet Torque Values					
		Hex/Socket Head		Flat Head	
		 			
Fastener Grade	Size x Pitch	Nm	Ft-lb	Nm	Ft-lb
CL 10.9	M8 x 1.25	29	22	23	17
	M10 x 1.50	61	45	49	36
	M12 x 1.75	105	78	85	62
	M14 x 1.50	150	111	121	88
	M14 x 2.00	170	126	138	100
	M16 x 2.00	265	196	216	156
	M20 x 1.50	456	337	372	269
	M20 x 2.50	517	382	422	305
	M24 x 3.00	894	660	731	528
	M27 x 3.00	1312	968	1072	774
	M30 x 3.50	1779	1312	1453	1049
	M36 x 4.00	3110	2294	2542	1835
8	1/4-20	13	10	11	8
	5/16-18	27	20	22	16
	3/8-16	50	37	40	29
	7/16-14	80	59	65	47
	1/2-13	122	90	99	72
	1/2-20	138	102	112	81
	5/8-11	244	180	199	144
	3/4-10	433	320	354	256
	7/8-9	698	515	570	412
	1.00-8	1046	772	854	617
	1.00-14	1175	867	960	693
	1.25-7	2095	1545	1712	1236
8/L9	1.50-6	3644	2688	2979	2150

O-RING BOSS & FLAT FACE O-RING TORQUE SPECIFICATIONS

O-Ring Boss Torque Values		
Size Dash	Nm	Ft-lb
-4	22	16
-5	27	20
-6	36	26
-8	83	60
-10	110	80
-12	187	135
-14	249	180
-16	304	220
-20	387	280
-24	498	360

Flat Face O-Ring Torque Values		
Size Dash	Nm	Ft-lb
-4	18	13
-6	30	22
-8	60	44
-10	85	62
-12	121	88
-14	121	88
-16	160	116
-20	213	154
-24	274	198

BOLT DRIVE SPECIFICATIONS

Thread Size x Pitch	Hex Head	Socket Head	Flat Head
			
Wrench/Drive Size			
M8 x 1.25	13mm	6mm	5mm
M10 x 1.50	17mm	8mm	6mm
M12 x 1.75	19mm	10mm	8mm
M14 x 1.50	22mm	12mm	10mm
M14 x 2.00	22mm	12mm	10mm
M16 x 2.00	24mm	14mm	10mm
M20 x 1.50	30mm	17mm	12mm
M20 x 2.50	30mm	17mm	12mm
M24 x 3.00	36mm	19mm	14mm
M27 x 3.00	41mm	19mm	-
M30 x 3.50	46mm	22mm	-
M36 x 4.00	55mm	27mm	-
1/4-20	7/16"	3/16"	5/32"
5/16-18	1/2"	1/4"	3/16"
3/8-16	9/16"	5/16"	7/32"
7/16-14	5/8"	3/8"	1/4"
1/2-13	3/4"	3/8"	5/16"
1/2-20	3/4"	3/8"	5/16"
5/8-11	15/16"	1/2"	3/8"
3/4-10	1-1/8"	5/8"	1/2"
7/8-9	1-5/16"	3/4"	9/16"
1.00-8	1-1/2"	3/4"	5/8"
1.00-14	1-1/2"	3/4"	5/8"
1.25-7	1-7/8"	7/8"	7/8"
1.50-6	2-1/4"	1"	1"

WARRANTY

Claim Procedure

Notify the Genesis Service Department of the potential warranty claim prior to making the repair. Digital pictures are very helpful for diagnosing problems and recommending repairs.

Contact the Genesis Service Department before making alterations, changes or repairs to any component that is going to be considered for warranty. Not doing so will void all Genesis warranty consideration.

The Genesis Service Department will issue an authorization number to track the repair costs, outgoing parts, and/or defective parts returning to the factory.

Replacement parts must be ordered using a purchase order number. Shipping is standard ground. Overnight shipping is available by request, and Genesis will not cover the shipping charge.

When the repair is complete, submit an invoice to the Genesis Service Department within 30 days. Include itemized internal labor reporting, parts lists and invoices for outside contractors. Reference the authorization number on all invoices.

When returning parts for warranty consideration, include a copy of any related Genesis paperwork along with any other necessary documentation to ensure proper processing and credit. The Genesis Service Department will provide the necessary forms.

Your account will be credited when the warranty claim is accepted.

Blade Warranty

Standard warranty on blades will only be considered on the first edge, and wear on the edge must be 1/8" radius or less. Genesis does not warranty cutting blades that are cracked or broken from top to bottom (perpendicular to the long edge of the blade). Genesis also does not cover fasteners, the labor to replace wear components or collateral damage, such as blade seats, from broken blades, the piercing blade tang or adjustment plates.

Please direct any questions to the Genesis Service Department: 715-395-5252

PARTS ORDER POLICY AND PROCEDURE

Parts Orders Should Include

- Purchase order number
- Model and serial number of attachment
- Part number and quantity needed
- Shipping and billing address
- Method of shipment or required delivery date

Placing Orders

Orders may be placed by phone or e-mail. To e-mail an order, use the form on the following page or your purchase order form. Contact information is located at the front of this manual.

Part Numbers

Part numbers are listed in a separate Parts Manual or, if included, the Parts section of this manual. Contact the Genesis Parts Department with questions regarding part numbers, availability and pricing.

Shipping

All orders will be shipped best way surface unless an alternate shipping method is requested. Shipping charges are not included in the purchase price of parts.

Invoices

All invoices are due upon receipt. Any accounts with invoices open beyond 60 days are subject to review and may be placed on C.O.D. status without further notice.

Returns

Many unused Genesis parts may be returned with proper documentation. Return shipping is the responsibility of the purchaser. Credit will be issued upon return, less a 25% restocking fee. Documentation is required for credit of returned parts. Contact the Genesis Service Department at 715-395-5252 for an RGA (Return Goods Authorization) number and form. An RGA must accompany every return. Items shipped without an RGA may be returned to sender.

Warranty Returns

All parts returned to Genesis for warranty consideration must be returned with a completed RGA (Return Goods Authorization) provided by the Genesis Service Department. The form needs to be completed in its entirety, including any additional information requested by the Service Department. Return shipping is the responsibility of the sender and will be credited upon claim approval. A determination to accept or deny the claim will be made based upon the information available to Genesis. Warranty on purchased parts other than wear components is 6 months. Genesis does not cover labor costs to replace purchased parts replaced under warranty. There is no warranty period on wear parts or components.

INDEX

1/8 NPT Plug	31	6300817 Cartridge - Relief	31
2-Port Spool	31	6300900 Slewing Ring	19
#6 SAE Plug	31	6300901 Pinion	19
8-Port Housing	31	6300902 Cartridge - Crossport Relief	19
2200221 Mach Guard Mount Bar	7, 9, 11, 13	6340010 Hydraulic Motor	19
2200222 Wtmg Under Guard	13	6350108 Sub-Assembly Cyl B4.50 x R3.0 x S8.0	9, 11
2200232 Mach Washer	7, 9, 11, 13	6350109 Sub-Assembly Cyl B4.50 x R3.0 x S10.0	13
2200235 Wtmg Frame	13	6350110 Sub-Assembly Cyl B4.50 x R3.0 x S7.0	7
2200246 Wtmg Outer Guard	13	Adjustment Screw Internal Hex Size	36, 37
2200257 Wtmg Frame	11	Assembly Cylinder	5
2200275 Wtmg Outer Guard	11	Assembly Frame	5
2200279 Wtmg Under Guard	11	Assembly Gland Seals	26
2200291 Wtmg, Head GSG 50/65/75/100/125	15	Assembly Head	5
2200298 Plate, End Cover	15	Assembly Hydraulic	5, 34
2200299 Plate, Bolt Cover	15	Assembly Piston Seals	28
2200300 Plate, Side Cover	15	Assembly Rotation	5, 18
2200304 Mach Pin Keeper	15, 17	Assembly Swivel	5, 35
2200306 Plate Bar Strap	15, 17	Assembly Swivel - 6350089	30
2200401 Wldt Pin 2.50 x 11.75	7, 9, 11, 13	Assembly Swivel Seals - Detailed View	32
2200404 Wldt Pin 2.50 x 8.13	11, 13	Assembly Tine	5
2200416 Wldt Pin Std	15, 17	Assembly Yoke	5, 40
2200426 Wtmg Tine Med. Spade - Point - GSG 250	13	Assembly Yoke (Forked Stick)	38
2200433 Wtmg Tine Med. Spade - Point - GSG 200	13	Bolt Drive Specifications	48
2200441 Wtmg Tine Med. Spade - Point - GSG 150	13	Bolt Torque Specifications	42, 46
2200449 Wtmg Tine Med. Spade - Point - GSG 125	11	Buffer Seal / Prac Seal	21, 23, 25, 27
HD	11	Butt and Tube Assembly	21, 23, 25
2200457 Wtmg Tine Med. Spade - Point - GSG 100	11	BU-Wiper	21, 23, 25, 27, 29
HD	11	Cartridge, Crossport Relief - 6300817	37
2200499 Wtmg Frame - Light Weight	9	Cartridge, Crossport Relief - 6300902	36
2200501 Wtmg, Head GSG 150/200/250	17	Contact Information	2, 54
2200502 Plate, End Cover	17	Crown Seal	31, 33
2200503 Plate, Side Cover	17	F0108030 Hex Head Capscrew M8 x 1.25 x 30	17
2200504 Wtmg Under Guard - Light Weight	9	F0112020 Hex Head Capscrew M12 x 1.75 x 20	17
2200505 Wtmg Tine Med. Spade - Point - Light Weight - GSG100	9	F0112030 Hex Head Capscrew M12 x 1.75 x 30	15, 17
2200506 Wtmg Outer Guard - Light Weight	9	F0116030 Hex Head Capscrew M16 x 2 x 30	7, 9, 11, 13
2200542 Wtmg Tine Med. Spade - Point - Light Weight - GSG 125	9	F0116080 Hex Head Capscrew M16 x 2 x 80	19
2200547 Wldt Pin 2.50 x 8.00	7, 9	F0124050 Hex Head Capscrew M24 x 2.0 x 50	7, 9, 11, 13
2200600 Wtmg Outer Guard - Light Weight	7	F0263100 Hex Head Capscrew 5/8 - 18 x 1	19
2200601 Wtmg Under Guard - Light Weight	7	F0612070 Socket Head Capscrew M12 x 1.75 x 70	19
2200602 Wtmg Tine Med. Spade - Point - Light Weight - GSG 75	7	F0616110 Socket Head Capscrew M16 x 2.0 x 110	35
2200603 Wtmg Tine Med. Spade - Point - Light Weight - GSG 50	7	F1200817 Flat Washer M8	17
2200608 Wtmg Frame - Light Weight	7	F1201224 Flat Washer M12	15, 17
2200610 Plate, Bolt Cover	17	F1201630 Flat Washer M16	7, 9, 11, 13, 19
2200640 Wtmg Tine Med. Spade - Point - Light Weight - GSG 65	7	F1310058 Flat Washer Wide .58 x 1.75	7, 9, 11, 13
5300449 Hose	35	F1317563 Flat Washer	19
6200002 Grease Fitting 1/8-27 NPT	7, 9, 11, 13, 15, 17	F1401200 Lock Washer M12	15, 17, 19
6300094 Compression Connector	15, 17	General Arrangement	4
6300149 Adaptor - 10MB-08MO	35	Grease Fitting	39, 41
6300302 Adaptor - 08MB-08MO-45	35	GSG 50/65/75/100/125 Assembly Upper Head - 2200500	14
6300634 Seal Kit	37	GSG 50/65/75 Assembly Cylinder - 6350091	20
		GSG 50/65/75 Assembly Frame / Tine	6
		GSG 100/125 Assembly Cylinder - 6350071	22

INDEX

GSG 100/125 Assembly Frame / Tine 10
GSG 100/125 Assembly Frame / Tine Light Weight 8
GSG 150/200/250 Assembly Cylinder - 6350072 24
GSG 150/200/250 Assembly Upper Head - 2200290 16
Locknut Hex Size 36, 37
Locknut Torque 36, 37
Lockwasher M10 31
Mach Bearing 39
Mach Bearing and Seal 41
Mach Pin Keeper 41
Manifold Tube Assembly 21, 23, 25
Nylock Hex Head 41
O-Ring 21, 23, 25, 27, 29, 31, 33
O-Ring Boss & Flat Face O-Ring Torque Specifications 47
Parts Order Form 51
Pin Wiper 21, 23, 25
Piston Seal 21, 23, 25, 29
Piston Tube Assembly 21, 23, 25
Procedures 44, 45
Retaining Ring 31, 33
Rod Seal 21, 23, 25, 27
Seal Kit 31, 33
Set Screw 1/4-20 21, 23, 25
Set Screw 5/16-18 21, 23, 25
SK00135 Seal Kit 36
Socket Head Capscrew 41
Socket Head Capscrew M10 x 1.50 x 30 31
Steel Bushing 21, 23, 25
Steel Spacer 21, 23, 25
Table of Contents 3
Thread Treatment Diagram 43
Torque Arm 31
Unitized Gland 21, 23, 25, 27
Unitized Piston 21, 23, 25, 29
Valve Hex Size 36, 37
Valve Installation Torque 36, 37
Warranty 49
Wear Ring 31, 33
Wiper 21, 23, 25, 27
Wldt Pin Drill 41
Wtmg Yoke 39, 41



GENESIS®

The Promise of Performance.

CONTACT INFORMATION

Genesis Attachments

1000 Genesis Drive
Superior, WI 54880 USA

Toll Free: 888-SHEAR-IT
(888-743-2748)

Phone: 715.395.5252

E-mail:
info@genesisattachments.com

Europe/Africa/Middle East Genesis GmbH

Teramostrasse 23
87700 Memmingen, Germany

Phone: +49 83 31 9 25 98 0

Fax: +49 83 31 9 25 98 80

genesis-europe.com

E-mail:
info@genesis-europe.com

Asia Pacific Representative Office

24 Upper Serangoon View #12-28
Singapore 534205

Phone: +65 9673 9730

E-mail:
tchoo@genesisattachments.com

Central America & Colombia

Cra 13A #89-38 / Ofi 613
Bogota, Colombia

Phone: +57 1 610 8160 / 795 8747

E-mail:
contact@themsagroup.com

View and download all manuals: genesisattachments.com/manuals

Patents: genesisattachments.com/products/patents