

# Razer X Multi-Jaw Demolition Tool (GRX 395)

## PARTS MANUAL



## CONTACT INFORMATION

### Genesis Attachments

1000 Genesis Drive  
Superior, WI 54880 USA

Toll Free: 888-SHEAR-IT  
(888-743-2748)

Phone: 715.395.5252

E-mail:  
info@genesisattachments.com

### Europe/Africa/Middle East Genesis GmbH

Teramostrasse 23  
87700 Memmingen, Germany

Phone: +49 83 31 9 25 98 0  
Fax: +49 83 31 9 25 98 80  
genesis-europe.com

E-mail:  
info@genesis-europe.com

### Asia Pacific Representative Office

24 Upper Serangoon View #12-28  
Singapore 534205

Phone: +65 9673 9730

E-mail:  
tchoo@genesisattachments.com

### Central America & Colombia

Cra 13A #89-38 / Ofi 613  
Bogota, Colombia

Phone: +57 1 610 8160 / 795 8747

E-mail:  
contact@themsagroup.com

View and download all manuals: [genesisattachments.com/manuals](http://genesisattachments.com/manuals)  
Patents: [genesisattachments.com/products/patents](http://genesisattachments.com/products/patents)

# TABLE OF CONTENTS

<b>CONTACT INFORMATION</b> .....	<b>2</b>
<b>GENERAL ARRANGEMENT</b> .....	<b>4</b>
<b>ASSEMBLY PIVOT GROUP</b> .....	<b>6</b>
<b>ASSEMBLY BLADE KIT CRACKER JAW</b> .....	<b>8</b>
<b>ASSEMBLY LOWER BLADES SHEAR JAW</b> .....	<b>10</b>
<b>ASSEMBLY UPPER BLADES SHEAR JAW</b> .....	<b>12</b>
<b>ASSEMBLY BLADE KIT PULVERIZER JAW</b> .....	<b>14</b>
<b>ASSEMBLY LUGS</b> .....	<b>16</b>
<b>ASSEMBLY MAIN CYLINDER</b> .....	<b>18</b>
<b>ASSEMBLY BODY CYLINDERS</b> .....	<b>20</b>
<b>REGEN BLOCK SUB-ASSEMBLY 6300763</b> .....	<b>22</b>
<b>ASSEMBLY SUB-HEAD</b> .....	<b>24</b>
<b>ASSEMBLY SUB-HEAD WITH DUMP VALVE</b> .....	<b>26</b>
<b>SUB-ASSEMBLY LINE MOUNT MANIFOLD</b> .....	<b>28</b>
<b>ASSEMBLY SWIVEL MANIFOLD 6350135</b> .....	<b>30</b>
<b>SPLIT FLANGE KITS USED IN THIS MANUAL</b> .....	<b>32</b>
<b>BOLT TORQUE SPECIFICATIONS</b> .....	<b>33</b>
<b>THREAD TREATMENT DIAGRAM</b> .....	<b>34</b>
Mobile Shears.....	34
Processors.....	35
<b>PROCEDURES</b> .....	<b>36</b>
Cleaning.....	36
Threadlocker.....	36
Anti-Seize.....	37
No Thread Treatment.....	37
<b>BOLT TORQUE SPECIFICATIONS</b> .....	<b>38</b>
Dry Torque Values.....	38
Wet Torque Values.....	38
<b>O-RING BOSS &amp; FLAT FACE O-RING TORQUE SPECIFICATIONS</b> .....	<b>39</b>
<b>BOLT DRIVE SPECIFICATIONS</b> .....	<b>40</b>
<b>WARRANTY</b> .....	<b>41</b>
Claim Procedure.....	41
Blade Warranty.....	41
<b>PARTS ORDER POLICY AND PROCEDURE</b> .....	<b>42</b>
Parts Orders Should Include.....	42
Placing Orders.....	42
Part Numbers.....	42
Shipping.....	42
Invoices.....	42
Returns.....	42
Warranty Returns.....	42
<b>PARTS ORDER FORM</b> .....	<b>43</b>
<b>INDEX</b> .....	<b>44</b>
<b>CONTACT INFORMATION</b> .....	<b>47</b>

# GENERAL ARRANGEMENT

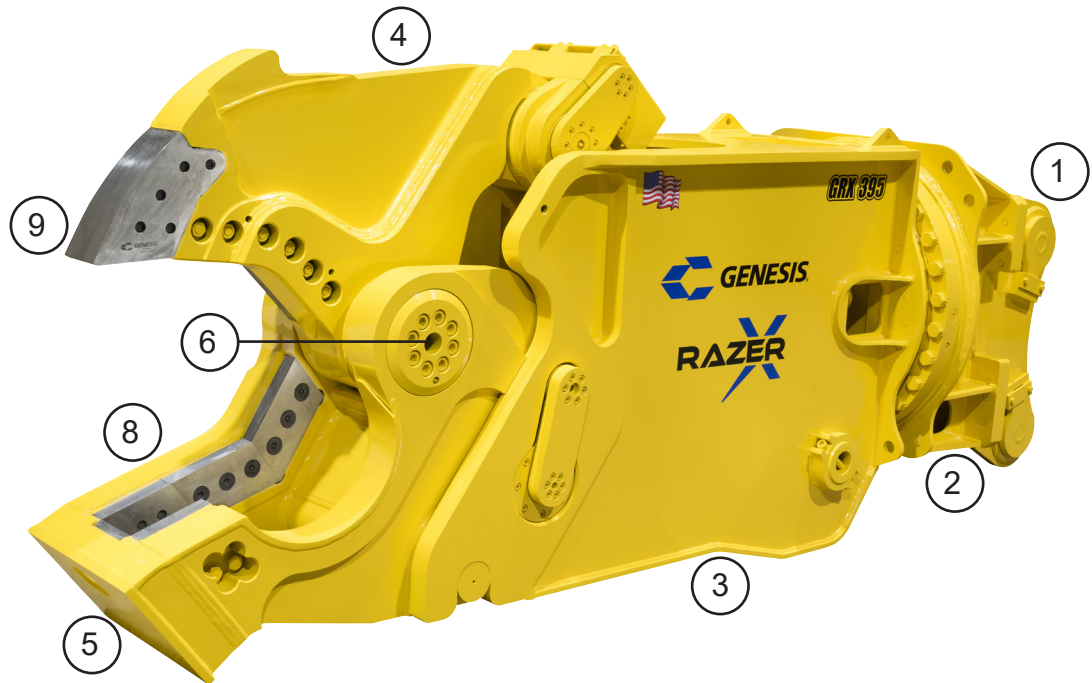
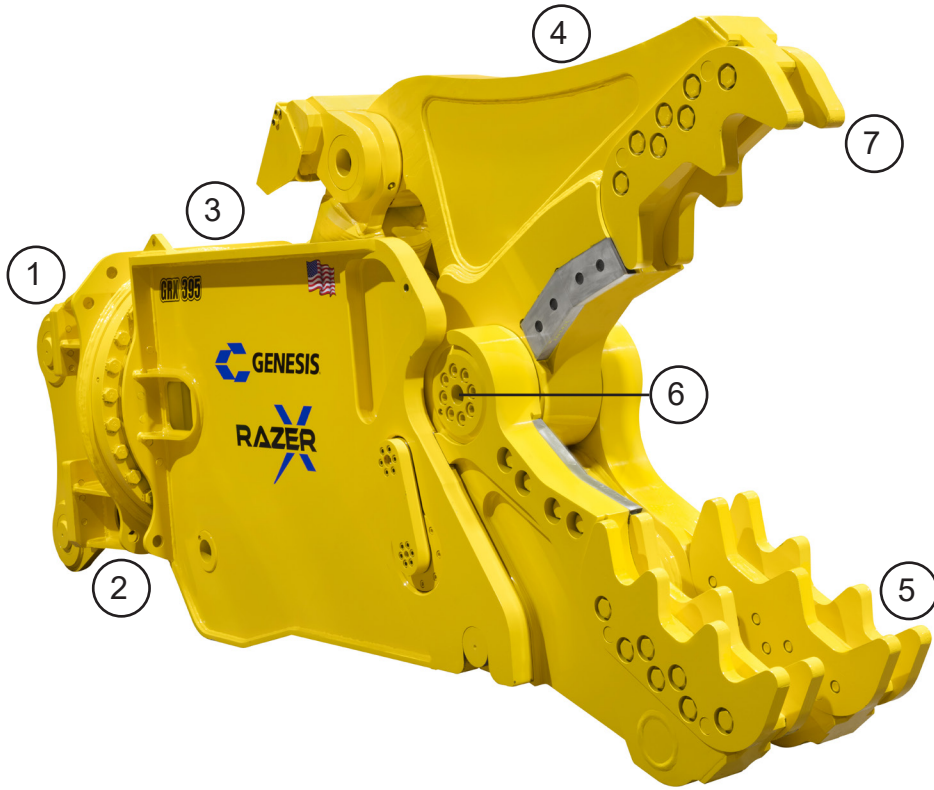

## GENERAL ARRANGEMENT

ITEM	QTY	PART NUMBER			DESCRIPTION
		<b>Cracker Jaw</b>	<b>Shear Jaw</b>	<b>Pulverizer Jaw</b>	
1		*			Assembly Lugs
2		See page 24 & 26			Assembly Sub-Head
3		3502447			Wtmg Body
4	1	3502474	3502405	3502619	Wtmg Upper Jaw
5	1	3502503	3502409	3502620	Wtmg Lower Jaw
6		See page 6			Assembly Pivot Group
7		See page 8	—	—	Assembly Blade Kit Cracker Jaw
8		—	See page 10	—	Assembly Lower Blades Shear Jaw
9		—	See page 12	—	Assembly Upper Blades Shear Jaw
10		—	—	See page 14	Assembly Blade Kit Pulverizer Jaw

\* Part number is Serial Number specific. For replacement parts call the Genesis Parts Department.

**USA**  
715-395-3488

**Europe**  
+49 83 31 9 25 98 0

# ASSEMBLY PIVOT GROUP

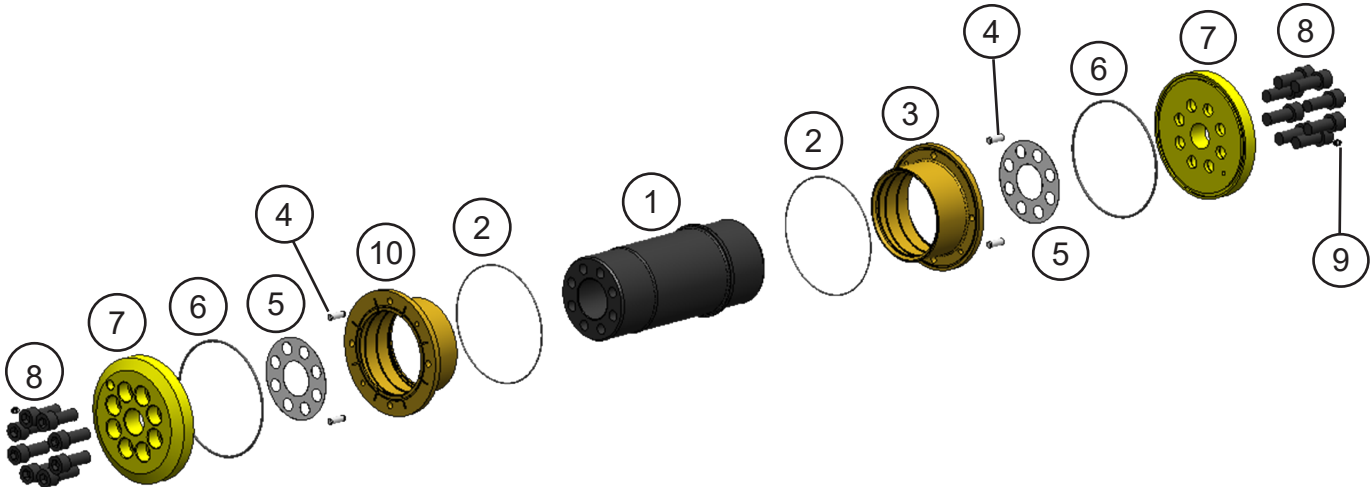

## ASSEMBLY PIVOT GROUP

ITEM	QTY	PART NUMBER			DESCRIPTION
		Cracker Jaw	Shear Jaw	Pulverizer Jaw	
1	1	3502509	3502461	3502652	Mach Main Shaft
2	2	S0190270			O-Ring
3	1	3501100			Mach Bearing
4	4	6300134			Mach Dowel
5	2	3500360			Shim Set
6	2	S0190372			O-Ring
7	2	3501099			Mach End Cap
8	16	F0624060			Socket Head Capscrew M24 x 3 x 60
9	2	6200002			Grease Fitting
10	1	3501100	3502414	3501100	Mach Bearing

# ASSEMBLY BLADE KIT CRACKER JAW

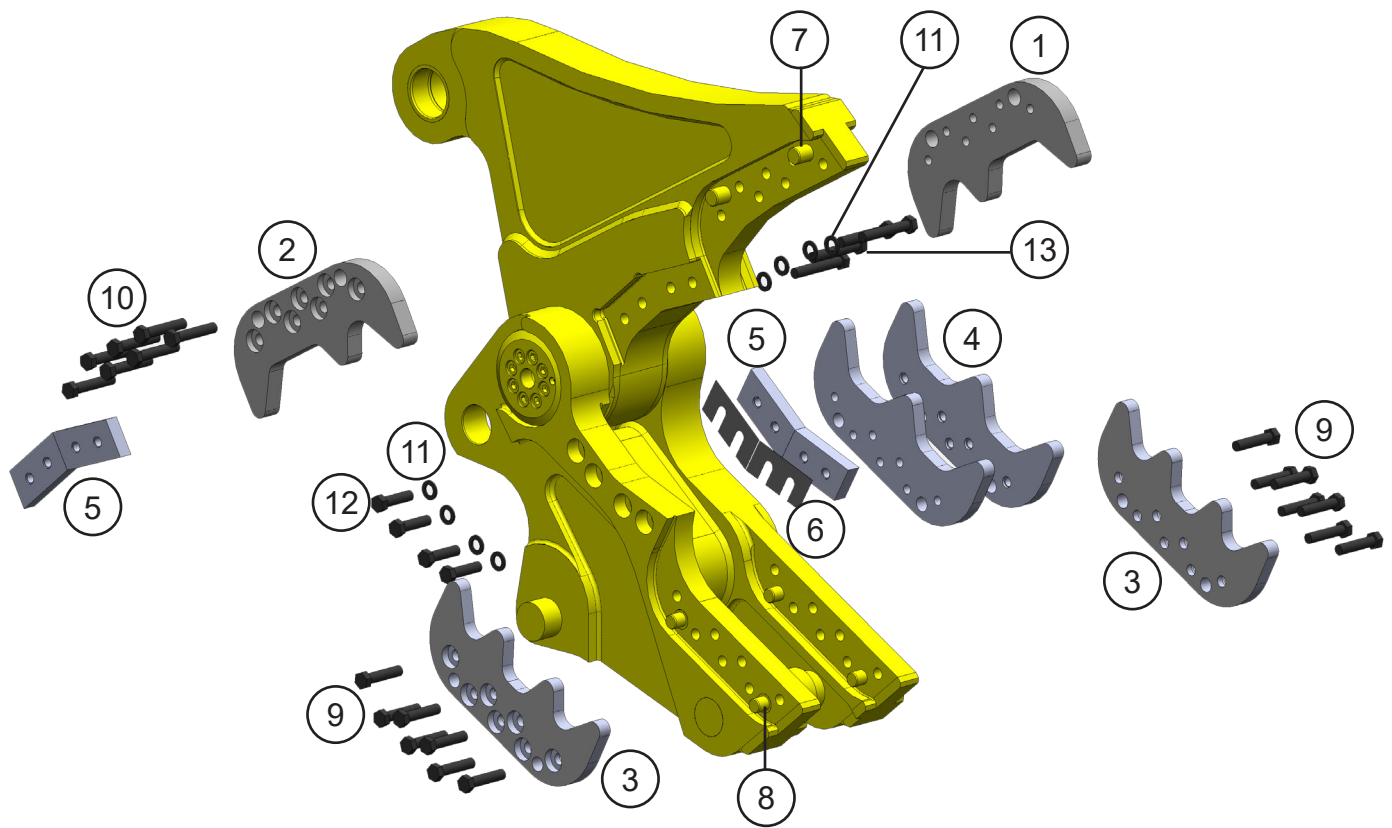



## ASSEMBLY BLADE KIT CRACKER JAW

ITEM	QTY	PART NUMBER	DESCRIPTION
1	1	3502293	Mach Tooth Upper LH
2	1	3502291	Mach Tooth Upper RH
3	2	3502094	Mach Tooth Lower Outside
4	2	3502090	Mach Tooth Lower Inside
5	4	3502013	Mach Blade
6	2	3502035	Shim Set
7	2	3502513	Mach Pin Teeth Upper
8	4	3502512	Mach Pin Teeth Lower
9	14	F0127120	Hex Head Capscrew M27 x 3 x 120
10	7	F0127140	Hex Head Capscrew M27 x 3 x 140
11	8	F1202750	Flat Washer M27
12	4	F0127100	Hex Head Capscrew M27 x 3 x 100
13	4	F0127160	Hex Head Capscrew M27 x 3 x 160

# ASSEMBLY LOWER BLADES SHEAR JAW

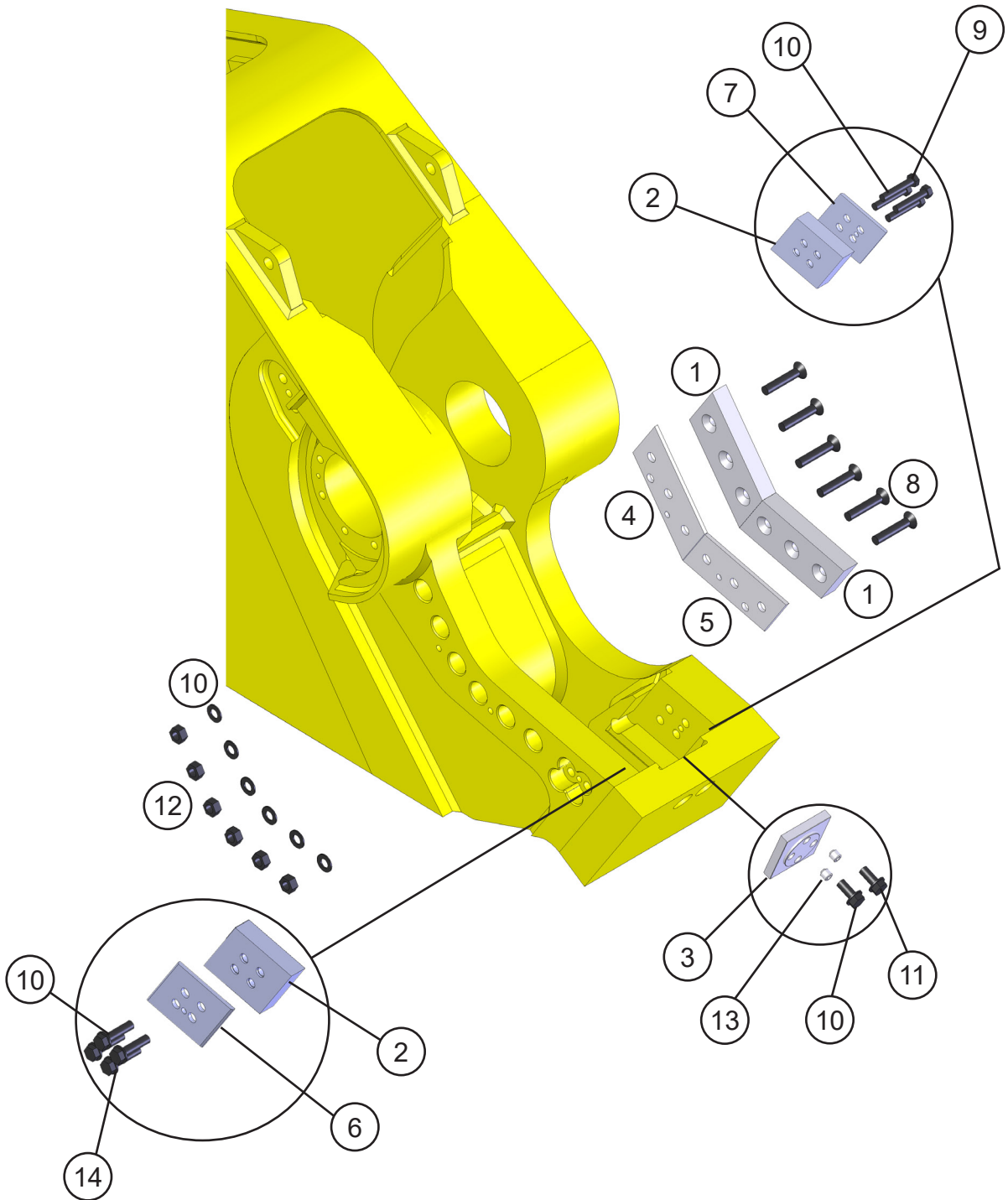

## ASSEMBLY LOWER BLADES SHEAR JAW

ITEM	QTY	PART NUMBER	DESCRIPTION
1	2	1106876	Mach Blade
2	2	1105941	Mach Blade Guide
3	1	1101955	Mach Blade Razor
4	1	1106877	Mach Adjust Plate
5	1	1106879	Mach Adjust Plate
6	1	1106413	Mach Guide Blade Adjust Plate
7	1	1106414	Mach Guide Blade Adjust Plate
8	6	F0588450	Flat Head Capscrew $\frac{7}{8}$ - 9 x $4\frac{1}{2}$
9	4	F0288450	Hex Head Capscrew $\frac{7}{8}$ - 9 x $4\frac{1}{2}$
10	16	F1300088	Flat Washer Narrow $\frac{7}{8}$
11	2	F0288200	Hex Head Capscrew $\frac{7}{8}$ - 9 x 2
12	6	F0908809	Hex Nut $\frac{7}{8}$ - 9
13	2	F2588088	Set Screw Socket Head $\frac{7}{8}$ - 9 x $\frac{7}{8}$
14	4	F0288350	Hex Head Capscrew $\frac{7}{8}$ - 9 x $3\frac{1}{2}$
<b>SHIM SET</b>			
		1105397	Shim Set, Blade
		1106477	Shim Set, Guide Blade

# ASSEMBLY UPPER BLADES SHEAR JAW

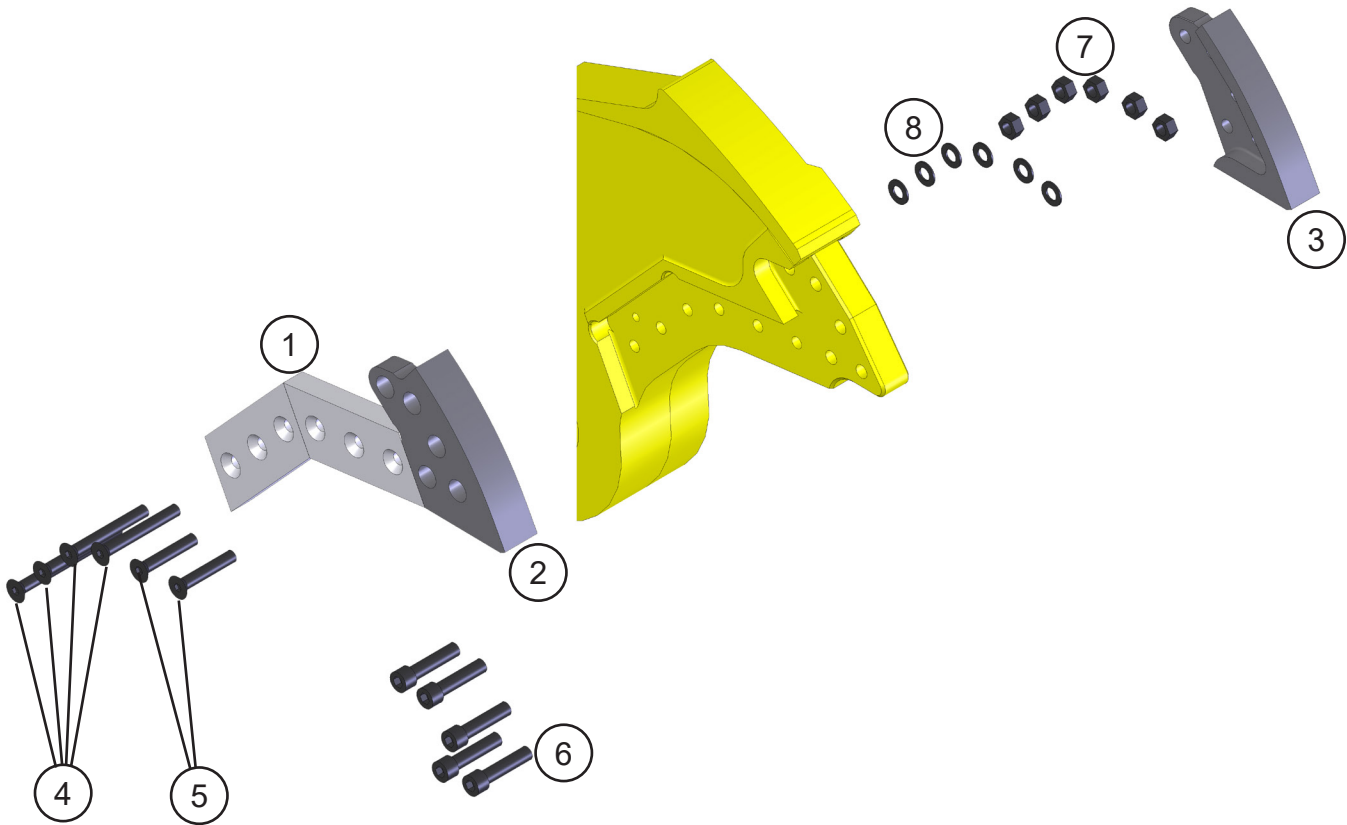

## ASSEMBLY UPPER BLADES SHEAR JAW

ITEM	QTY	PART NUMBER	DESCRIPTION
1	2	1106876	Mach Blade
2	1	1105939	Mach Blade Tip Right
3	1	1105940	Mach Blade Tip Left
4	4	F0588600	Flat Head Capscrew $\frac{7}{8}$ - 9 x 6
5	2	F0588500	Flat Head Capscrew $\frac{7}{8}$ - 9 x 5
6	5	1103609	Mach Bolt Socket Head Capscrew 1 - 8 x 4 $\frac{1}{2}$
7	6	F0908809	Hex Nut $\frac{7}{8}$ - 9
8	6	F1300088	Flat Washer Narrow $\frac{7}{8}$

# ASSEMBLY BLADE KIT PULVERIZER JAW

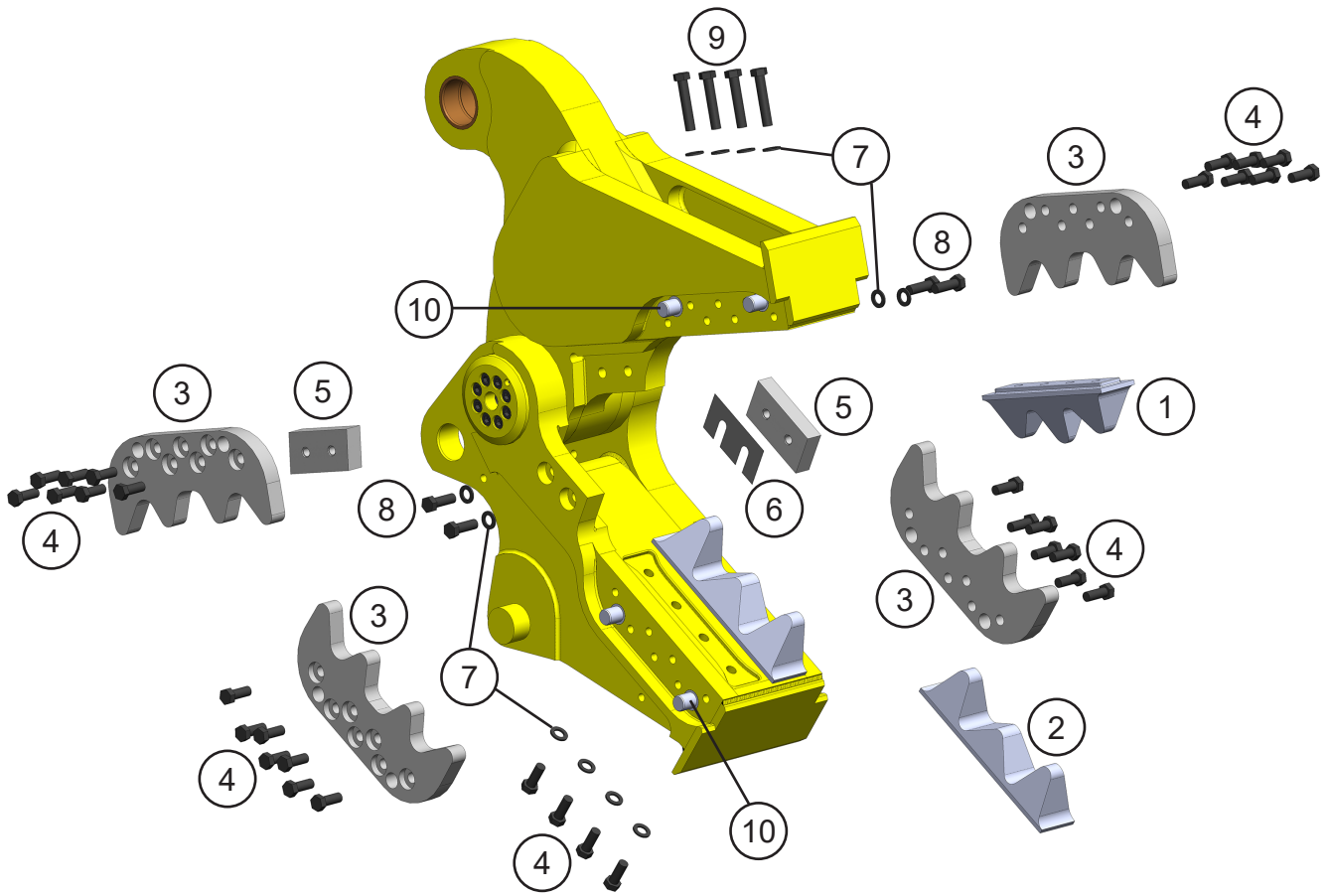

## ASSEMBLY BLADE KIT PULVERIZER JAW

ITEM	QTY	PART NUMBER	DESCRIPTION
1	1	3502658	Mach Tooth Inside Upper
	1	3502642	Cast Tooth Inside Upper
2	2	3502657	Mach Tooth Inside Lower
	2	3502644	Cast Tooth Inside Lower
3	4	3502297	Mach Tooth Outside
4	36	F0127070	Hex Head Capscrew M27 x 3 x 70
5	2	3502299	Mach Blade
6	1	3502301	Shim Set
7	16	F1202750	Flat Washer M27
8	4	F0127080	Hex Head Capscrew M27 x 3 x 80
9	4	F0127140	Hex Head Capscrew M27 x 3 x 140
10	8	3502647	Mach Teeth Pin

# ASSEMBLY LUGS

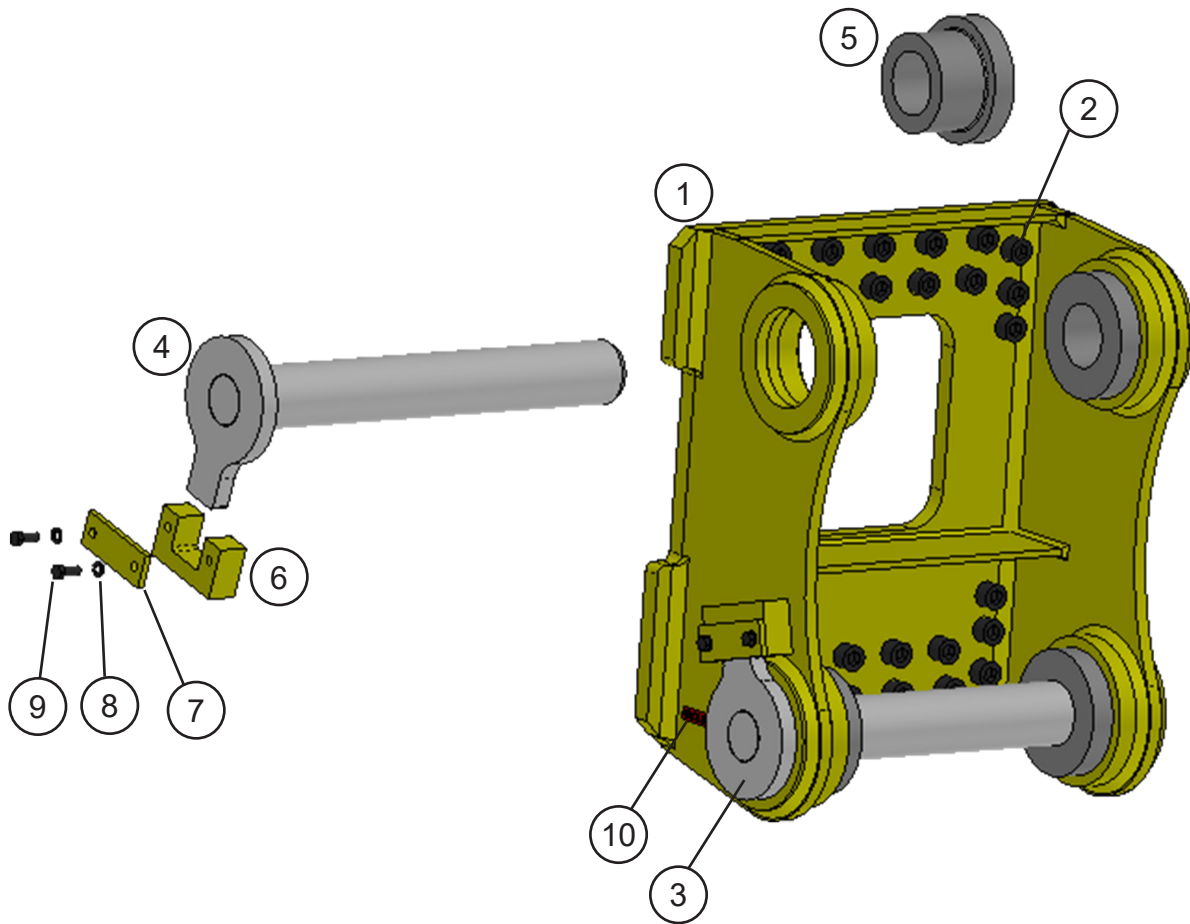



## ASSEMBLY LUGS

ITEM	QTY	PART NUMBER	DESCRIPTION
1	1	**	Wtmg Lugs
2	*	**	Bracket Fasteners
3	1	**	Wldt Stick Pin
4	1	**	Wldt Link Pin
5	*	**	Mach Spacer Sleeve
6	2	**	Mach Pin Keeper
7	2	**	Bar Strap
8	4	**	Washer
9	4	**	Hex Head Capscrew
10	1	**	Stick Pin Decal

\* Quantity is dependent upon the bracket.

\*\* Part number is Serial Number specific. For replacement parts call the Genesis Parts Department.

**USA**

715-395-3488

**Europe**

+49 83 31 9 25 98 0

# ASSEMBLY MAIN CYLINDER

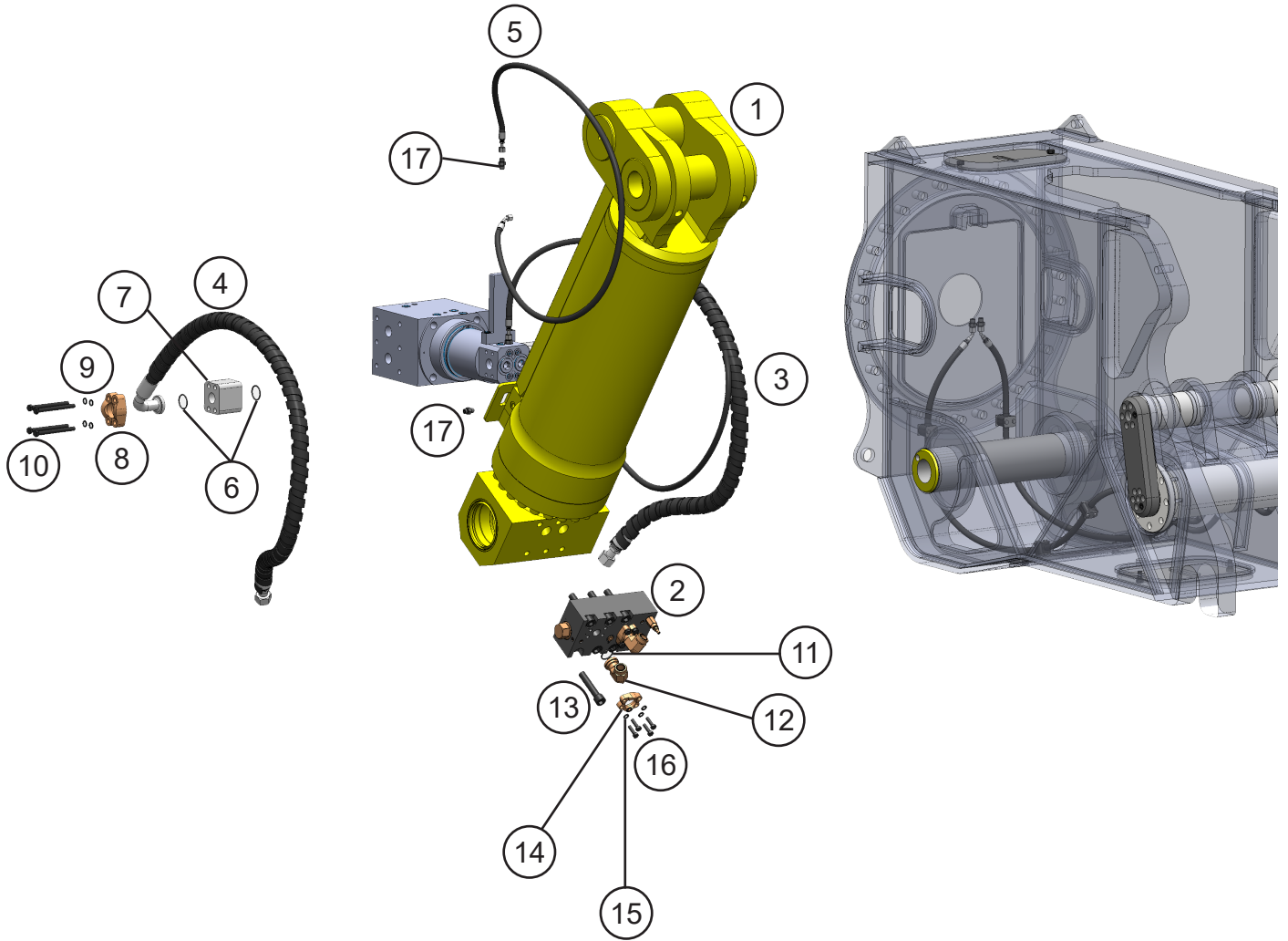

## ASSEMBLY MAIN CYLINDER

ITEM	QTY	PART NUMBER	DESCRIPTION
1	1	6350149	Hydraulic Cylinder
2	1	6300763	Valve - GenFlow
3	1	3502460	Hose
4	1	3502459	Hose
5	2	3502466	Hose
6	4	S0190222	O-Ring
7	2	6310256	Mach Port Spacer
8	4	H0262125	Split Flange Half 1.25 Code 62
9	8	F1900050	Nord Lock Washer
10	8	F0112130	Hex Head Capscrew M12 x 1.75 x 130
11	2	S0190219	O-Ring
12	2	6310004	Flange Adapter
13	6	F0620100	Socket Head Capscrew M20 x 2.5 x 100
14	4	H0261100	Split Flange Half 1.00 Code 61
15	8	F1401000	Lock Washer M10
16	8	F0110035	Hex Head Capscrew M10 x 1.50 x 35
17	4	6310011	Adapter

# ASSEMBLY BODY CYLINDERS

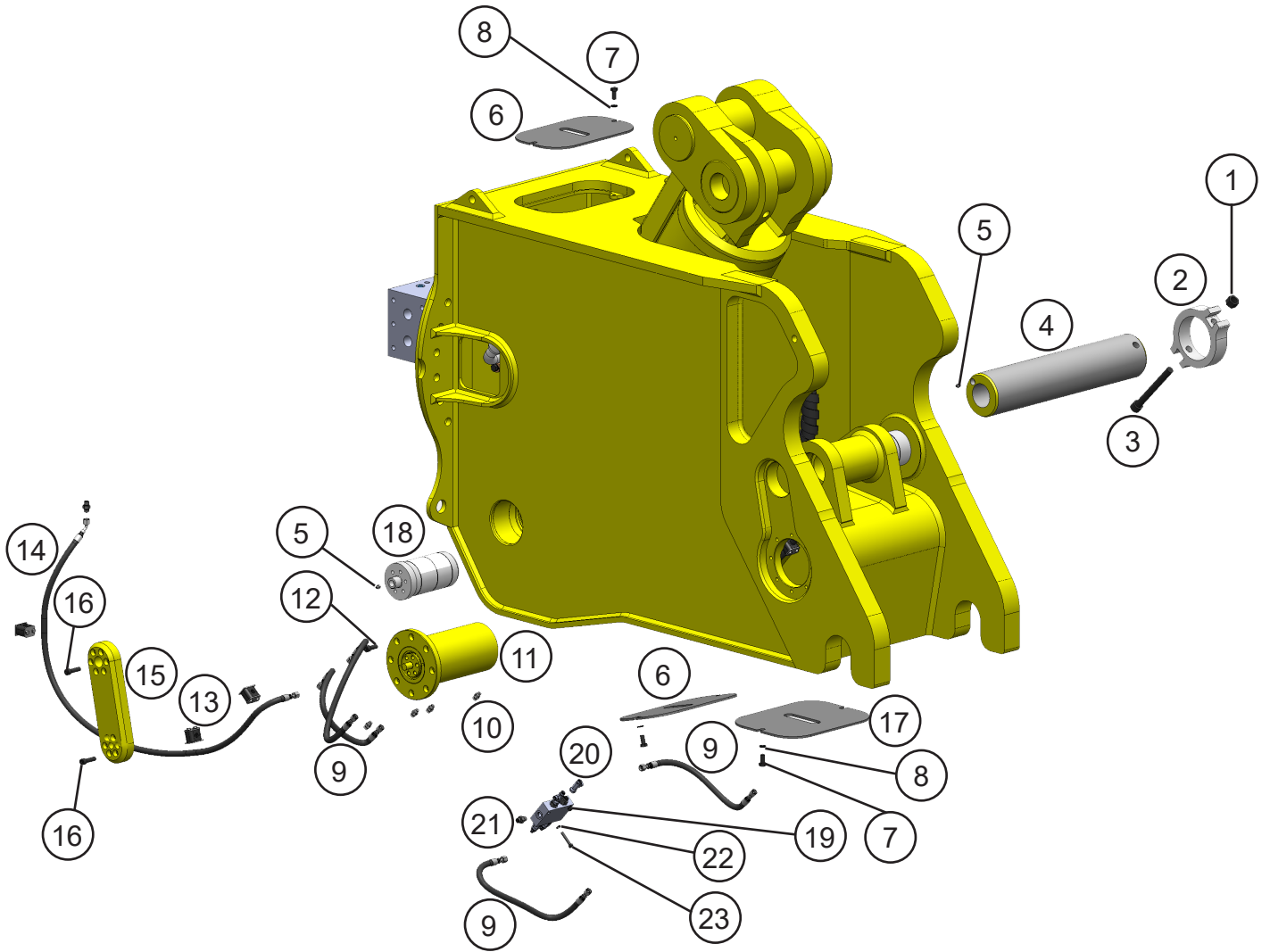

## ASSEMBLY BODY CYLINDERS

ITEM	QTY	PART NUMBER	DESCRIPTION
1	1	F1020250	Nylock Nut
2	1	1103607	Mach Pin Keeper
3	1	F0620180	Socket Head Capscrew M20 x 2.5 x 180
4	1	3502453	Mach Pin
5	3	6200002	Grease Fitting
6	2	3502457	PLT Cover
7	6	F0112025	Hex Head Capscrew M12 x 1.75 x 25
8	6	F1900050	Nord Lock Washer
9	4	3502465	Hose
10	4	6300770	Adapter
11	2	6350137	Hydraulic Cylinder
12	16	F0612030	Socket Head Capscrew M12 x 1.75 x 30
13	6	6300737	Hose Clamp
14	2	3502464	Hose
15	2	3502455	Mach Pin Link
16	24	F0612040	Socket Head Capscrew M12 x 1.75 x 40
17	1	3502458	Plt Cover
18	2	3502454	Mach Pin
19	1	6360106	Cyl Lock Valve
20	2	6300883	Adapter
21	2	6310011	Adapter
22	2	F1900031	Nord Lock Washer
23	2	F0108045	Hex Head Capscrew M8 x 1.25 x 45

# REGEN BLOCK SUB-ASSEMBLY 6300763

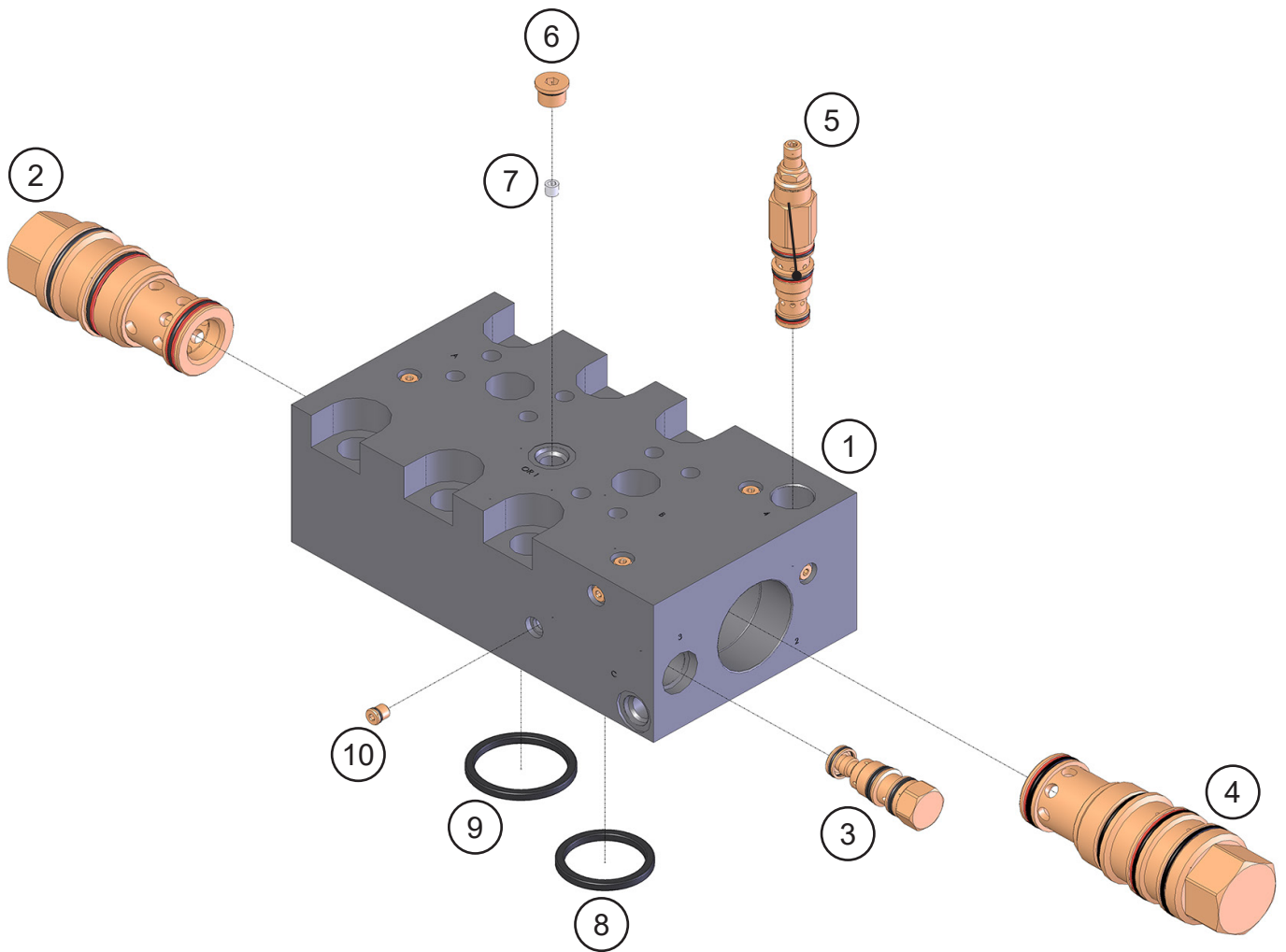

## REGEN BLOCK SUB-ASSEMBLY 6300763

ITEM	QTY	PART NUMBER	DESCRIPTION
1	1	6300796	Mach Regen Manifold <b>Seal Kit SK00047</b>
2	1	6300061	Valve Check COHA-XCV <b>Seal Kit SK00024</b>
3	1	6300621	Valve Shuttle CSAB-XXV <b>Seal Kit 6300622</b>
4	1	6300623	Valve Logic DKHS-XHV <b>Seal Kit 6300624</b>
5	1	6300625	Valve PSI Reducer PRDB-LWV <b>Seal Kit 6300622</b>
6	1	6300153	Zero Leak Plug
7	1	3500023	Mach Orifice
8	1	6300638	O-Ring 1p-3705 High PSI Seal 2.0 OD
9	1	6300723	O-Ring 1p-3705 High PSI Seal 2.25 OD
10	1	6300075	Plug Socket Head 02MB

# ASSEMBLY SUB-HEAD

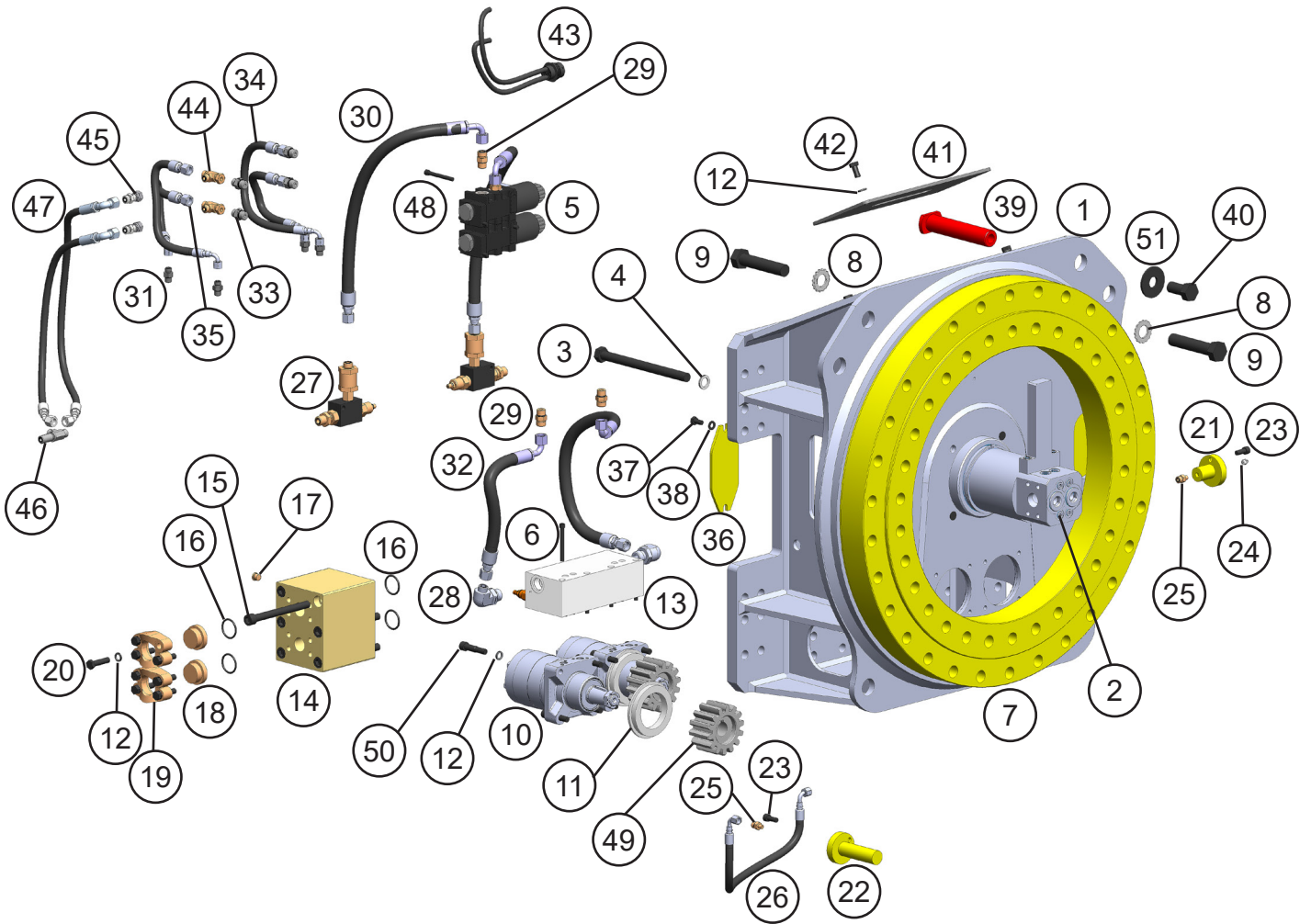



## ASSEMBLY SUB-HEAD

ITEM	QTY	PART NUMBER	DESCRIPTION	ITEM	QTY	PART NUMBER	DESCRIPTION
1	1	3502533	Wtmg Sub-Head	32	1	3502543	Hose
2	1	6350135	Swivel Manifold Assy	33	4	6310049	Adapter
3	4	F0120260	Hex Head Capscrew M20 x 2.50 x 260	34	3	3502544	Hose
4	4	F1900075	Nord Lock Washer	35	1	3502545	Hose
5	1	6830050	Assy Selector Valve GRX (12V) SN395101-SN395110	36	2	1105883	Cover
	1	6830065	Assy Selector Valve GRX (24V) SN395111 - Up	37	4	F0110020	Hex Head Capscrew M10 x 1.5 x 20
6	8	F0731300	Socket Head Capscrew 5/16 - 18 x 3	38	4	F1201021	Flat Washer M10
7	1	6300429	Slewing Ring	39	1	3501915	Mach Pin Rotation Lock
8	60	F2802700	Hytorc Washer	40	1	F0124050	Hex Head Capscrew M24 x 3.0 x 50
9	60	F0127130	Hex Head Capscrew M27 x 3 x 130	41	1	3502546	Cover
10	2	6380083	Hydraulic Motor	42	4	F0112025	Hex Head Capscrew M12 x 1.75 x 25
11	2	3501835	Mach Spacer	43	1	6830056	Assy Wiring Harness
12	28	F1900050	Nord Lock Washer	44	2	6300407	Adapter
13	1	6360098	Rotate Manifold	45	2	6310297	Adapter
14	2	1107091	Mach Port Block	46	1	6310343	Adapter Bulkhead
15	12	F0616170	Socket Head Capscrew M16 x 2.0 x 170	47	2	3502681	Hose
16	8	S0190222	O-Ring	48	4	F0608075	Socket Head Capscrew M8 x 1.25 x 75
17	4	6300153	Zero Leak Plug	49	2	3101235	Motor Pinion
18	4	H0362125	Split Flange Plug	50	8	1108183	Mach Socket Head Capscrew Custom
19	8	H0262125	Split Flange Half 1.25 Code 62	51	1	2200232	Mach Washer
20	16	F0112050	Hex Head Capscrew M12 x 1.75 x 50				
21	1	5512411	Mach Grease Bulkhead Adapter				
22	1	5512419	Mach Slewing Ring Grease Adapter				
23	2	F0610025	Socket Head Capscrew M10 x 1.50 x 25				
24	1	6200002	Grease Fitting				
25	2	6300731	Adapter				
26	1	3502680	Hose				
27	2	6301202	Flow Control Sub-Assy				
28	2	6310082	Adapter				
29	4	6300017	Adapter				
30	3	3502542	Hose				
31	4	6310011	Adapter				

# ASSEMBLY SUB-HEAD WITH DUMP VALVE

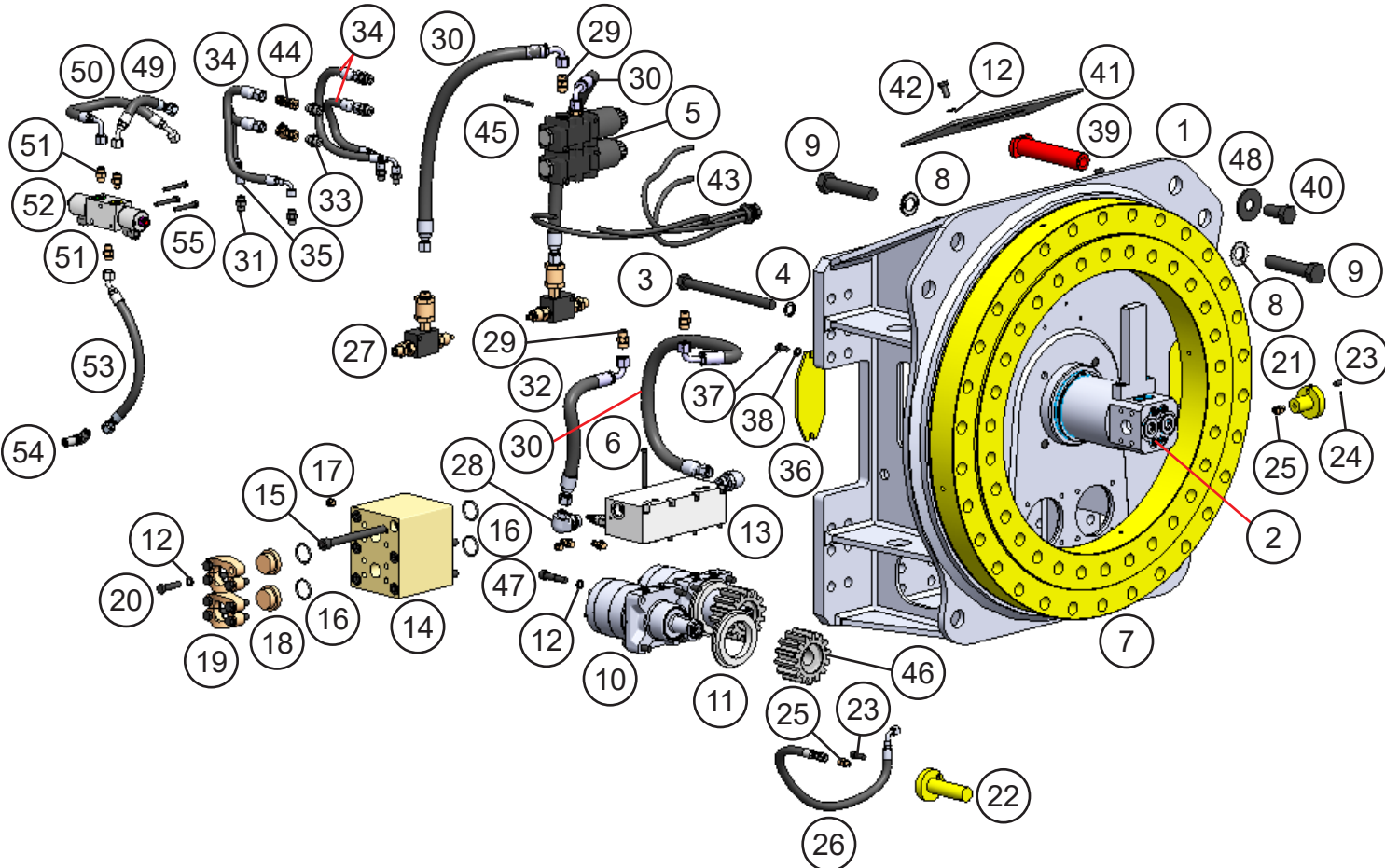

# ASSEMBLY SUB-HEAD WITH DUMP VALVE

ITEM	QTY	PART NUMBER	DESCRIPTION	ITEM	QTY	PART NUMBER	DESCRIPTION
1	1	3503533	Wtmg Sub-Head	31	4	6310011	Adapter
2	1	6350135	Swivel Manifold Assy	32	1	3502543	Hose
3	4	F0120260	Hex Head Capscrew M20 x 2.50 x 260	33	4	6310049	Adapter
4	4	F1900075	Nord Lock Washer	34	3	3502544	Hose
5	1	6830065	Assy Selector Valve GRX (24V)	35	1	3502545	Hose
6	8	F0731300	Socket Head Capscrew 5/16 - 18 x 3	36	2	1105883	Cover
7	1	6300429	Slewing Ring	37	4	F0110020	Hex Head Capscrew M10 x 1.5 x 20
8	60	F2802700	Hytorc Washer	38	4	F1201021	Flat Washer M10
9	60	F0127130	Hex Head Capscrew M27 x 3 x 130	39	1	3501915	Mach Pin Rotation Lock
10	2	6380083	Hydraulic Motor	40	1	F0124050	Hex Head Capscrew M24 x 3.0 x 50
11	2	3501835	Mach Spacer	41	1	3502546	Cover
12	28	F1900050	Nord Lock Washer	42	4	F0112025	Hex Head Capscrew M12 x 1.75 x 25
13	1	6360098	Rotate Manifold	43	1	6830064	Assy Wiring Harness
14	2	1107091	Mach Port Block	44	2	6300407	Adapter
15	12	F0616170	Socket Head Capscrew M16 x 2.0 x 170	45	4	F0608075	Socket Head Capscrew M8 x 1.25 x 75
16	8	S0190222	O-Ring	46	2	3101235	Motor Pinion
17	4	6300153	Zero Leak Plug	47	8	1108183	Mach Socket Head Capscrew Custom
18	4	H0362125	Split Flange Plug	48	1	2200232	Mach Washer
19	8	H0262125	Split Flange Half 1.25 Code 62	49	1	3503591	Hose
20	16	F0112050	Hex Head Capscrew M12 x 1.75 x 50	50	1	3503592	Hose
21	1	5512411	Mach Grease Bulkhead Adapter	51	3	6300018	Adapter
22	1	5512419	Mach Slewing Ring Grease Adapter	52	1	6360121	Dump Valve
23	2	F0610025	Socket Head Capscrew M10 x 1.50 x 25	53	1	3503593	Hose
24	1	6200002	Grease Fitting	54	1	6310264	Adapter
25	2	6300731	Adapter	55	3	F0108060	Hex Head Capscrew M8 x 1.25 x 60
26	1	3502680	Hose				
27	2	6301202	Flow Control Sub-Assy				
28	2	6310082	Adapter				
29	4	6300017	Adapter				
30	3	3502542	Hose				

# SUB-ASSEMBLY LINE MOUNT MANIFOLD

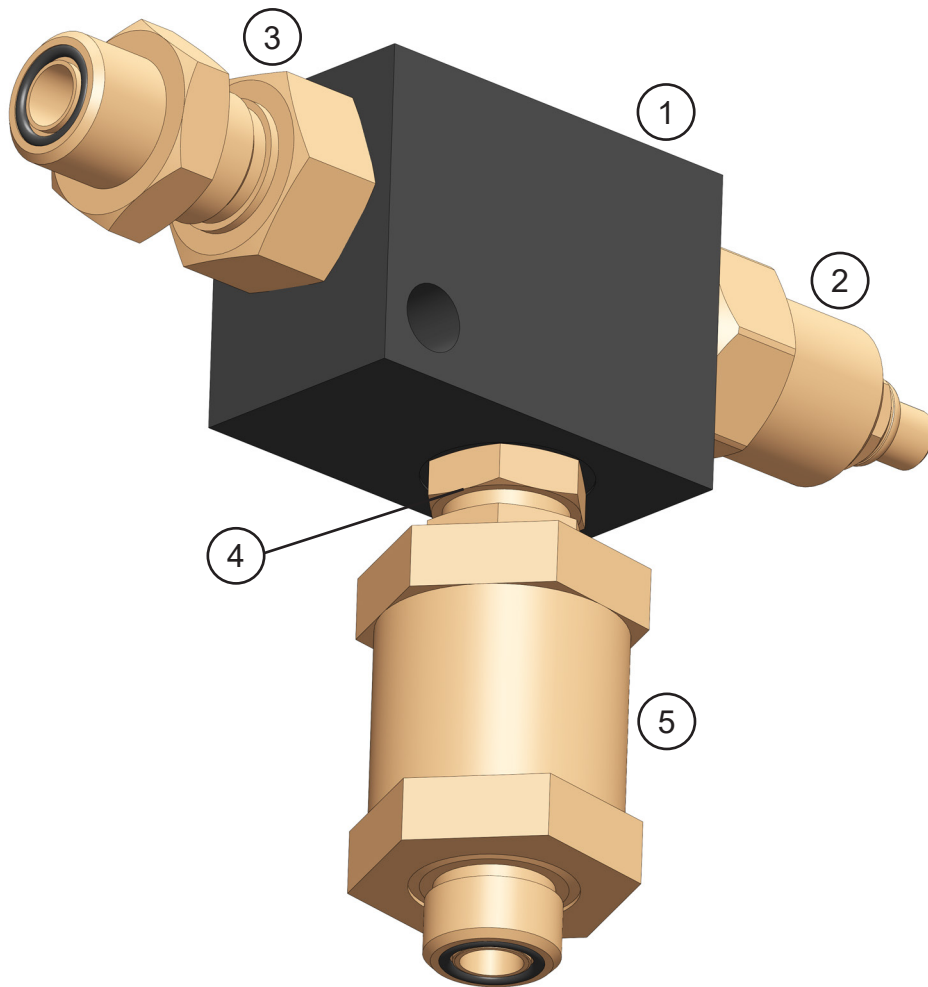

## SUB-ASSEMBLY LINE MOUNT MANIFOLD

ITEM	QTY	PART NUMBER	DESCRIPTION	
1	1	6300609	Valve Line Body	
2	1	6300361	Valve Flow Control	<b>Seal Kit 6300634</b>
3	1	6300497	Adaptor Bulkhead 08MB-08MO	
4	1	6310183	Adaptor 08MB-08MB	
5	1	6300364	Filter	

# ASSEMBLY SWIVEL MANIFOLD 6350135

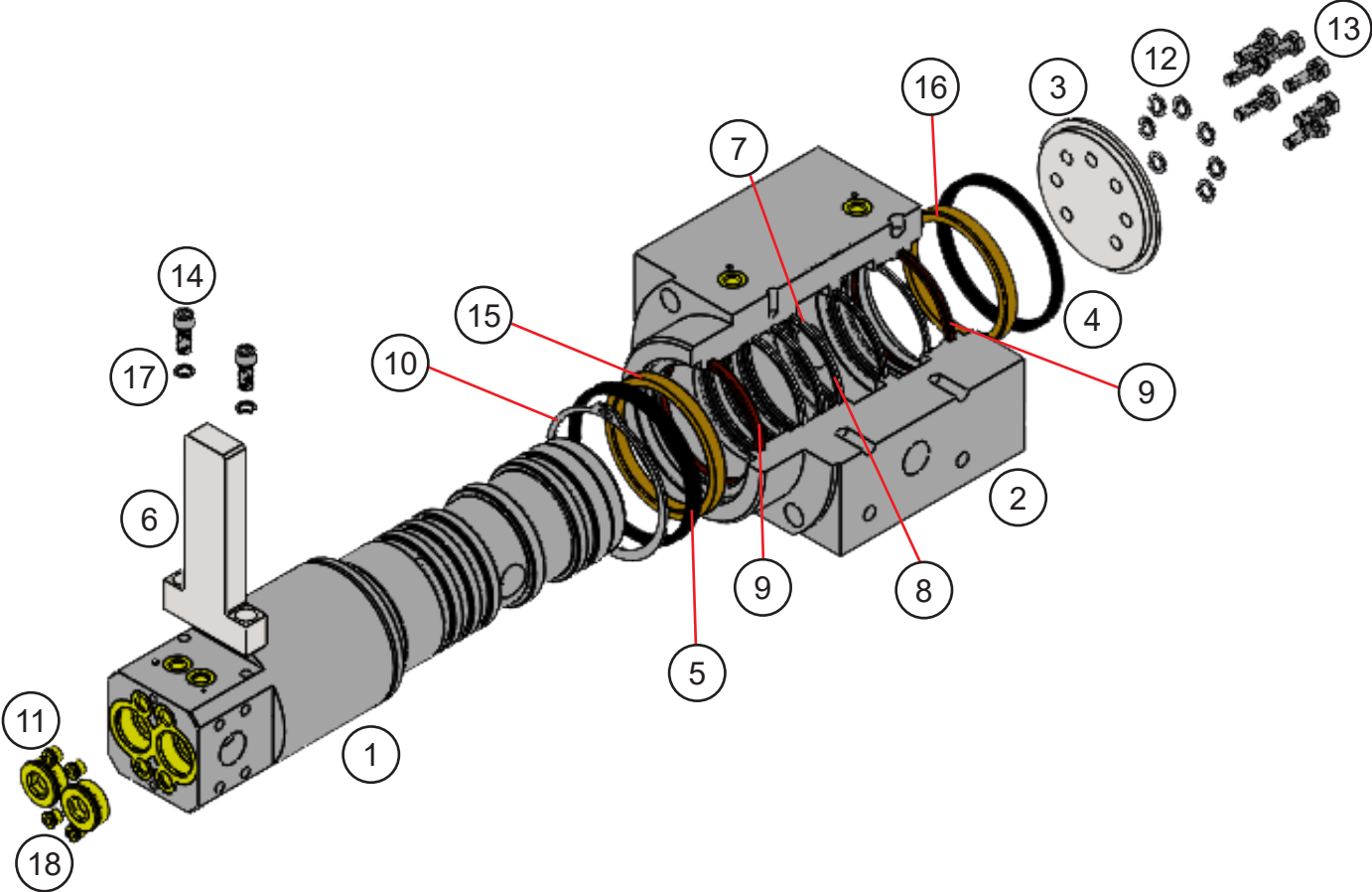

## ASSEMBLY SWIVEL MANIFOLD 6350135

ITEM	QTY	PART NUMBER	DESCRIPTION
1	1	For replacement parts call the Genesis Parts Department. USA 715-395-3488 Europe +49 83 31 9 25 98 0	Spool
2	1		Housing
3	1		Spool Plate
4	1		V-Ring Seal
5	1		V-Ring Seal
6	1		Torque Arm
7	5		Cap Seal
8	5		Energizer
9	2		U-Cup Seal
10	1		Ext Retaining Ring
11	2		Zero Leak Plug
12	7		Lock Washer
13	7		M12 x 1.75 x 35 C10.9 HHCS
14	2		M12 x 1.75 x 30 C12.9 SHCS
15	1		Head End Sleeve Bearing
16	1		Cap End Sleeve Bearing
17	2		M12 Hi-Collar Lock Washer
18	4		Zero Leak Plug

## SPLIT FLANGE KITS USED IN THIS MANUAL

### 1" Split Flange Kit - Code 61 - M10

QTY	PART NUMBER	DESCRIPTION
2	H0261100	Split Flange Half 1.00 Code 61
4	F0110035	Hex Head Capscrew M10 x 1.50 x 35
4	F1401000	Lock Washer M10
1	S0190219	O-Ring

### 1" Split Flange Kit - Code 62 - M10

QTY	PART NUMBER	DESCRIPTION
2	H0262100	Split Flange Half 1.00 Code 62
4	F0110040	Hex Head Capscrew M10 x 1.50 x 40
4	F1401000	Lock Washer M10
1	S0190219	O-Ring

### 1" Split Flange Kit - Code 62 - M12

QTY	PART NUMBER	DESCRIPTION
2	H0262100	Split Flange Half 1.00 Code 62
4	F0112040	Hex Head Capscrew M12 x 1.75 x 40
4	F1401200	Lock Washer M12
1	S0190219	O-Ring

### 1-1/4" Split Flange Kit - Code 62 - M12

QTY	PART NUMBER	DESCRIPTION
2	H0262125	Split Flange Half 1.25 Code 62
4	F0112050	Hex Head Capscrew M12 x 1.75 x 50
4	F1401200	Lock Washer M12
1	S0190222	O-Ring

### 1-1/4" Split Flange Kit - Code 62 - M14

QTY	PART NUMBER	DESCRIPTION
2	H0262125	Split Flange Half 1.25 Code 62
4	F0114050	Hex Head Capscrew M14 x 2.00 x 50
4	F1401400	Lock Washer M14
1	S0190222	O-Ring



## BOLT TORQUE SPECIFICATIONS

Reference the product Thread Treatment Diagrams beginning on page 34 to determine whether to use wet or dry torque values for specific bolts.

Reference Procedures on page 36 for threadlocker or anti-seize application and bolt and bolt hole cleaning.

Prior to torquing, clean all bolt holes, bolts and nuts to remove dirt, grease and oil, and identify bolt type.

Never re-torque bolts that use Loctite. If a bolt becomes loose or damaged after the initial use when Loctite was applied and the bolt was torqued, the bolt must be replaced.

Never break tightened bolts loose with a torque wrench. Doing so may break the torque wrench or take it out of calibration.

Torque wrenches should be calibrated on an annual basis.

When using a torque multiplier with a torque wrench, incorrect settings will be multiplied by the ratio of the torque wrench.

Never use an impact driver on a torque multiplier.

# THREAD TREATMENT DIAGRAM

## Mobile Shears

Use this diagram to determine what thread treatment, if any, is required for each fastener.

For thread treatment application procedures, see page 36. For prescribed torque values, see page 38.

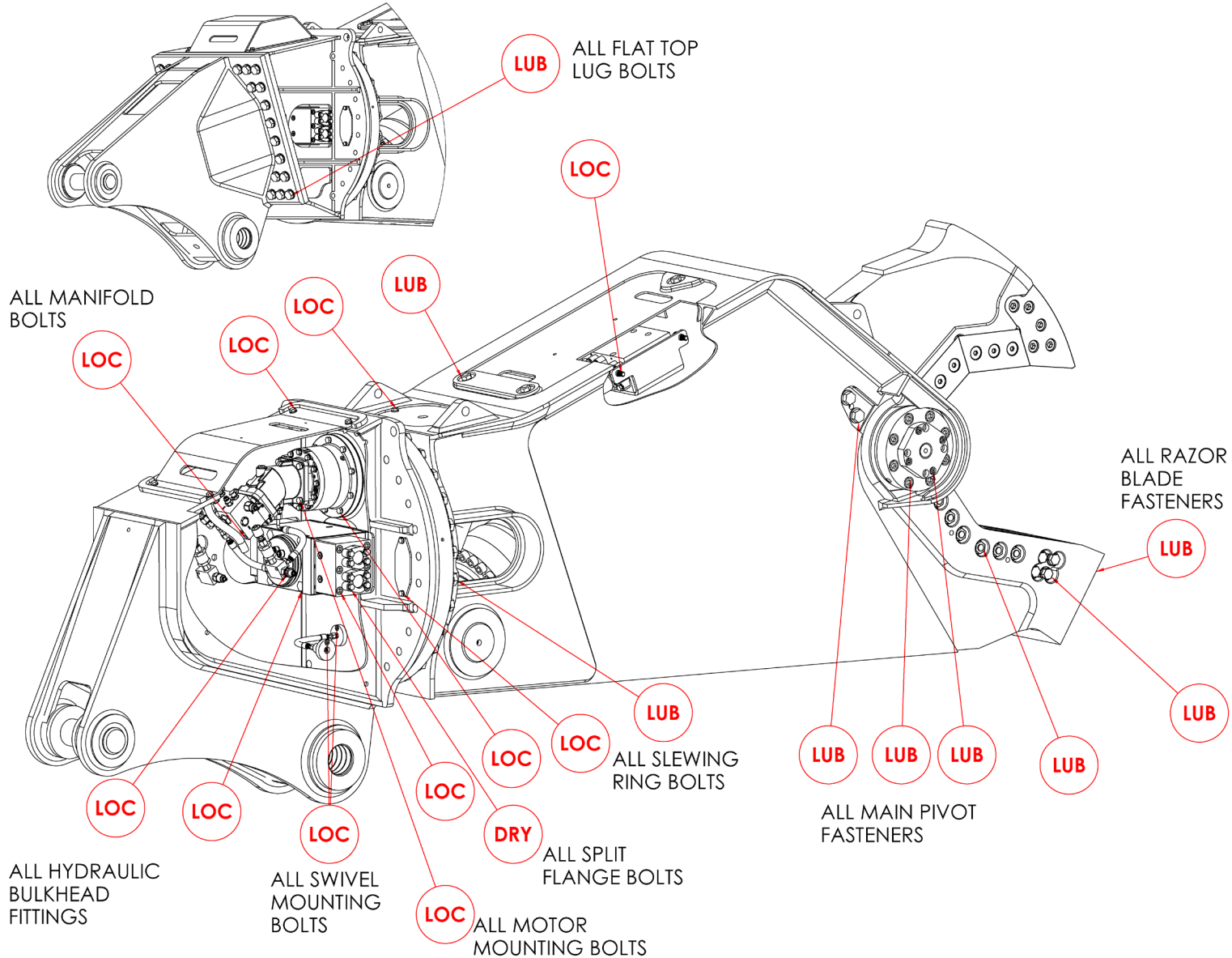

# THREAD TREATMENT DIAGRAM

## Processors

Use this diagram to determine what thread treatment, if any, is required for each fastener.

For thread treatment application procedures, see page 36. For prescribed torque values, see page 38.

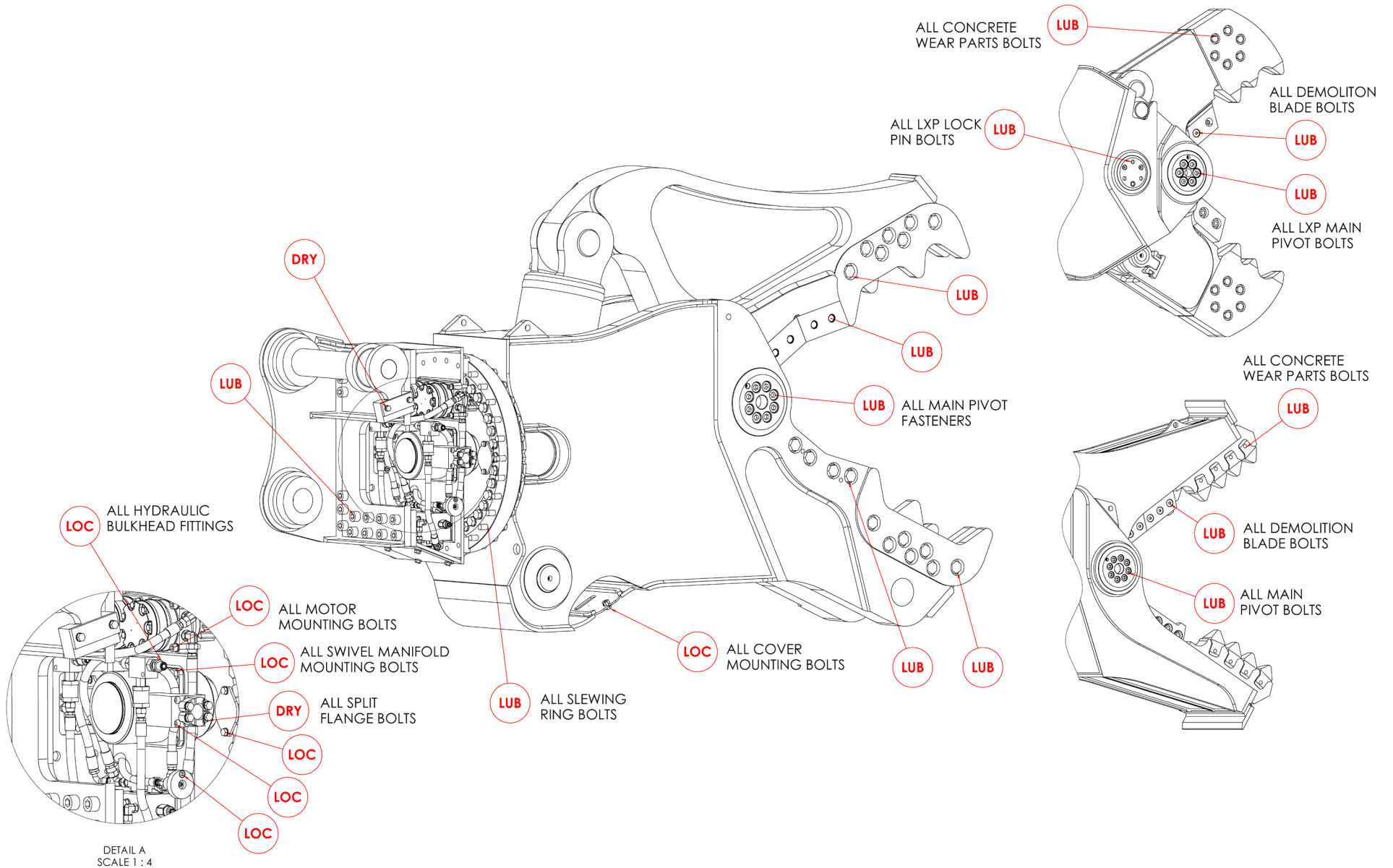

# PROCEDURES

Reference the product Thread Treatment Diagrams beginning on page 34 to determine which of the following procedures is required.

## Cleaning

To ensure proper performance of thread treatment and accurate torque values, clean and degrease **all internal and external threads** prior to application of threadlocker, anti-seize or primer and before installation of hardware.

- Ensure both internal and external threads are free of dirt or debris.
- Use brake cleaner or similar cleaning solvent on all threads to remove any grease or oil.
- Allow threads to dry.

## NOTICE

Failure to properly clean threads will cause threadlocker, primer, and/or anti-seize to not properly cure!

LOC

## Threadlocker

For bolted connections requiring threadlocker, use **Loctite 263** or equivalent applied using the following procedure:

- Clean and degrease all threads.
- For thru holes or nuts, apply threadlocker to bolt threads.
- For blind holes, apply stripe of threadlocker along the length of the hole (applying to the bolt can cause escaping air to remove threadlocker as the bolt is inserted).
- Torque bolt to specified **Wet Torque Value**, see page 38.

For threaded hydraulic fitting connections, use **Loctite 5452** or equivalent thread sealant in conjunction with **Loctite 7471** primer using the following procedure:

- Clean and degrease all threads.
- Apply Loctite 7471 primer to both external and internal threads and allow to dry.
- Apply threadlocker to 360 degrees of the threads on the male fitting, ensuring adequate coverage.
- Assemble fitting per directions in operator's manual.
- For O-ring boss and flat face O-ring connections, torque fittings to values specified on page 39.

Threadlocker

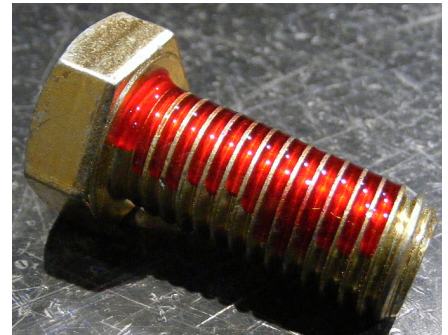

Blind Hole

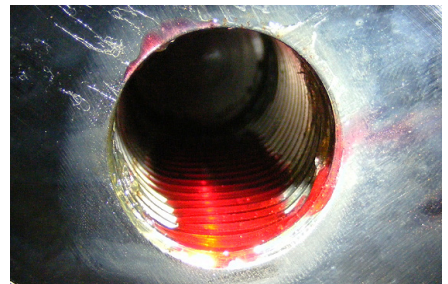

Hydraulic Fitting



## PROCEDURES

LUB

### Anti-Seize

For bolted connections requiring anti-seize lubrication, use **Loctite LB8008** or equivalent using the following procedure:

- Clean and degrease all threads.
- Apply thin coat of anti-seize to internal and external threads and under bolt head and/or nut, ensuring complete coverage.
- Torque bolt to specified **Wet Torque Value**, see page 38.

Anti-Seize









DRY

### No Thread Treatment

- Clean and degrease all threads.
- Torque bolt to specified **Dry Torque Value**, see page 38.

# BOLT TORQUE SPECIFICATIONS

<b>Dry Torque Values</b>						
		<b>Hex/Socket Head</b>		<b>Flat Head</b>		
						
Fastener Grade	Size x Pitch	Nm	Ft-lb	Nm	Ft-lb	
CL 10.9	M8 x 1.25	35	26	27	20	
	M10 x 1.50	71	53	58	42	
	M12 x 1.75	124	92	101	73	
	M14 x 1.50	200	148	163	118	
	M14 x 2.00	200	148	163	118	
	M16 x 2.00	311	230	254	184	
	M20 x 1.50	610	450	498	360	
	M20 x 2.50	608	449	497	359	
	M24 x 3.00	1054	778	861	622	
	M27 x 3.00	1543	1138	1260	910	
	M30 x 3.50	2095	1545	1712	1236	
	M36 x 4.00	3659	2699	2991	2159	
8	1/4-20	14	11	11	8	
	5/16-18	32	24	26	19	
	3/8-16	59	44	48	35	
	7/16-14	94	70	77	56	
	1/2-13	143	106	116	84	
	1/2-20	162	120	133	96	
	5/8-11	287	212	234	169	
	3/4-10	509	376	415	300	
	7/8-9	821	606	670	484	
	1.00-8	1232	909	1007	727	
	1.00-14	1383	1020	1130	816	
	1.25-7	2463	1817	2013	1453	
8/L9	1.50-6	4287	3162	3504	2529	

<b>Wet Torque Values</b>						
		<b>Hex/Socket Head</b>		<b>Flat Head</b>		
						
Fastener Grade	Size x Pitch	Nm	Ft-lb	Nm	Ft-lb	
CL 10.9	M8 x 1.25	29	22	23	17	
	M10 x 1.50	61	45	49	36	
	M12 x 1.75	105	78	85	62	
	M14 x 1.50	150	111	121	88	
	M14 x 2.00	170	126	138	100	
	M16 x 2.00	265	196	216	156	
	M20 x 1.50	456	337	372	269	
	M20 x 2.50	517	382	422	305	
	M24 x 3.00	894	660	731	528	
	M27 x 3.00	1312	968	1072	774	
	M30 x 3.50	1779	1312	1453	1049	
	M36 x 4.00	3110	2294	2542	1835	
8	1/4-20	13	10	11	8	
	5/16-18	27	20	22	16	
	3/8-16	50	37	40	29	
	7/16-14	80	59	65	47	
	1/2-13	122	90	99	72	
	1/2-20	138	102	112	81	
	5/8-11	244	180	199	144	
	3/4-10	433	320	354	256	
	7/8-9	698	515	570	412	
	1.00-8	1046	772	854	617	
	1.00-14	1175	867	960	693	
	1.25-7	2095	1545	1712	1236	
8/L9	1.50-6	3644	2688	2979	2150	

# O-RING BOSS & FLAT FACE O-RING TORQUE SPECIFICATIONS

O-Ring Boss Torque Values		
Size Dash	Nm	Ft-lb
-4	22	16
-5	27	20
-6	36	26
-8	83	60
-10	110	80
-12	187	135
-14	249	180
-16	304	220
-20	387	280
-24	498	360

Flat Face O-Ring Torque Values		
Size Dash	Nm	Ft-lb
-4	18	13
-6	30	22
-8	60	44
-10	85	62
-12	121	88
-14	121	88
-16	160	116
-20	213	154
-24	274	198

# BOLT DRIVE SPECIFICATIONS

Thread Size x Pitch	Hex Head	Socket Head	Flat Head
			
Wrench/Drive Size			
M8 x 1.25	13mm	6mm	5mm
M10 x 1.50	17mm	8mm	6mm
M12 x 1.75	19mm	10mm	8mm
M14 x 1.50	22mm	12mm	10mm
M14 x 2.00	22mm	12mm	10mm
M16 x 2.00	24mm	14mm	10mm
M20 x 1.50	30mm	17mm	12mm
M20 x 2.50	30mm	17mm	12mm
M24 x 3.00	36mm	19mm	14mm
M27 x 3.00	41mm	19mm	-
M30 x 3.50	46mm	22mm	-
M36 x 4.00	55mm	27mm	-
1/4-20	7/16"	3/16"	5/32"
5/16-18	1/2"	1/4"	3/16"
3/8-16	9/16"	5/16"	7/32"
7/16-14	5/8"	3/8"	1/4"
1/2-13	3/4"	3/8"	5/16"
1/2-20	3/4"	3/8"	5/16"
5/8-11	15/16"	1/2"	3/8"
3/4-10	1-1/8"	5/8"	1/2"
7/8-9	1-5/16"	3/4"	9/16"
1.00-8	1-1/2"	3/4"	5/8"
1.00-14	1-1/2"	3/4"	5/8"
1.25-7	1-7/8"	7/8"	7/8"
1.50-6	2-1/4"	1"	1"



# WARRANTY

## **Claim Procedure**

Notify the Genesis Service Department of the potential warranty claim prior to making the repair. Digital pictures are very helpful for diagnosing problems and recommending repairs.

Contact the Genesis Service Department before making alterations, changes or repairs to any component that is going to be considered for warranty. Not doing so will void all Genesis warranty consideration.

The Genesis Service Department will issue an authorization number to track the repair costs, outgoing parts, and/or defective parts returning to the factory.

Replacement parts must be ordered using a purchase order number. Shipping is standard ground. Overnight shipping is available by request, and Genesis will not cover the shipping charge.

When the repair is complete, submit an invoice to the Genesis Service Department within 30 days. Include itemized internal labor reporting, parts lists and invoices for outside contractors. Reference the authorization number on all invoices.

When returning parts for warranty consideration, include a copy of any related Genesis paperwork along with any other necessary documentation to ensure proper processing and credit. The Genesis Service Department will provide the necessary forms.

Your account will be credited when the warranty claim is accepted.

## **Blade Warranty**

Standard warranty on blades will only be considered on the first edge, and wear on the edge must be 1/8" radius or less. Genesis does not warranty cutting blades that are cracked or broken from top to bottom (perpendicular to the long edge of the blade). Genesis also does not cover fasteners, the labor to replace wear components or collateral damage, such as blade seats, from broken blades, the piercing blade tang or adjustment plates.

**Please direct any questions to the Genesis Service Department: 715-395-5252**

# PARTS ORDER POLICY AND PROCEDURE

## **Parts Orders Should Include**

- Purchase order number
- Model and serial number of attachment
- Part number and quantity needed
- Shipping and billing address
- Method of shipment or required delivery date

## **Placing Orders**

Orders may be placed by phone or e-mail. To e-mail an order, use the form on the following page or your purchase order form. Contact information is located at the front of this manual.

## **Part Numbers**

Part numbers are listed in a separate Parts Manual or, if included, the Parts section of this manual. Contact the Genesis Parts Department with questions regarding part numbers, availability and pricing.

## **Shipping**

All orders will be shipped best way surface unless an alternate shipping method is requested. Shipping charges are not included in the purchase price of parts.

## **Invoices**

All invoices are due upon receipt. Any accounts with invoices open beyond 60 days are subject to review and may be placed on C.O.D. status without further notice.

## **Returns**

Many unused Genesis parts may be returned with proper documentation. Return shipping is the responsibility of the purchaser. Credit will be issued upon return, less a 25% restocking fee. Documentation is required for credit of returned parts. Contact the Genesis Service Department at 715-395-5252 for an RGA (Return Goods Authorization) number and form. An RGA must accompany every return. Items shipped without an RGA may be returned to sender.

## **Warranty Returns**

All parts returned to Genesis for warranty consideration must be returned with a completed RGA (Return Goods Authorization) provided by the Genesis Service Department. The form needs to be completed in its entirety, including any additional information requested by the Service Department. Return shipping is the responsibility of the sender and will be credited upon claim approval. A determination to accept or deny the claim will be made based upon the information available to Genesis. Warranty on purchased parts other than wear components is 6 months. Genesis does not cover labor costs to replace purchased parts replaced under warranty. There is no warranty period on wear parts or components.



# INDEX

1-1/4" Split Flange Kit - Code 62 - M12	32	3502503 Wtmg Lower Jaw	5
1-1/4" Split Flange Kit - Code 62 - M14	32	3502509 Mach Main Shaft	7
1" Split Flange Kit - Code 61 - M10	32	3502512 Mach Pin Teeth Lower	9
1" Split Flange Kit - Code 62 - M10	32	3502513 Mach Pin Teeth Upper	9
1" Split Flange Kit - Code 62 - M12	32	3502533 Wtmg Sub-Head	25
1101955 Mach Blade Razor	11	3502542 Hose	25, 27
1103607 Mach Pin Keeper	21	3502543 Hose	25, 27
1103609 Mach Bolt Socket Head Capscrew 1 - 8 x 4½	13	3502544 Hose	25, 27
1105397 Shim Set, Blade	11	3502545 Hose	25, 27
1105883 Cover	25, 27	3502546 Cover	25, 27
1105939 Mach Blade Tip Right	13	3502619 Wtmg Upper Jaw	5
1105940 Mach Blade Tip Left	13	3502620 Wtmg Lower Jaw	5
1105941 Mach Blade Guide	11	3502642 Cast Tooth Inside Upper	15
1106413 Mach Guide Blade Adjust Plate	11	3502644 Cast Tooth Inside Lower	15
1106414 Mach Guide Blade Adjust Plate	11	3502647 Mach Teeth Pin	15
1106477 Shim Set, Guide Blade	11	3502652 Mach Main Shaft	7
1106876 Mach Blade	11, 13	3502657 Mach Tooth Inside Lower	15
1106877 Mach Adjust Plate	11	3502658 Mach Tooth Inside Upper	15
1106879 Mach Adjust Plate	11	3502680 Hose	25, 27
1107091 Mach Port Block	25, 27	3502681 Hose	25
1108183 Mach Socket Head Capscrew Custom	25, 27	3503533 Wtmg Sub-Head	27
2200232 Mach Washer	25, 27	3503591 Hose	27
3101235 Motor Pinion	25, 27	3503592 Hose	27
3500023 Mach Orifice	23	3503593 Hose	27
3500360 Shim Set	7	5512411 Mach Grease Bulkhead Adapter	25, 27
3501099 Mach End Cap	7	5512419 Mach Slewing Ring Grease Adapter	25, 27
3501100 Mach Bearing	7	6200002 Grease Fitting	7, 21, 25, 27
3501835 Mach Spacer	25, 27	6300017 Adapter	25, 27
3501915 Mach Pin Rotation Lock	25, 27	6300018 Adapter	27
3502013 Mach Blade	9	6300061 Valve Check COHA-XCV	23
3502035 Shim Set	9	6300075 Plug Socket Head 02MB	23
3502090 Mach Tooth Lower Inside	9	6300134 Mach Dowel	7
3502094 Mach Tooth Lower Outside	9	6300153 Zero Leak Plug	23, 25, 27
3502291 Mach Tooth Upper RH	9	6300361 Valve Flow Control	29
3502293 Mach Tooth Upper LH	9	6300364 Filter	29
3502297 Mach Tooth Outside	15	6300407 Adapter	25, 27
3502299 Mach Blade	15	6300429 Slewing Ring	25, 27
3502301 Shim Set	15	6300497 Adaptor Bulkhead 08MB-08MO	29
3502405 Wtmg Upper Jaw	5	6300609 Valve Line Body	29
3502409 Wtmg Lower Jaw	5	6300621 Valve Shuttle CSAB-XXV	23
3502414 Mach Bearing	7	6300623 Valve Logic DKHS-XHV	23
3502447 Wtmg Body	5	6300625 Valve PSI Reducer PRDB-LWV	23
3502453 Mach Pin	21	6300638 O-Ring 1p-3705 High PSI Seal 2.0 OD	23
3502454 Mach Pin	21	6300723 O-Ring 1p-3705 High PSI Seal 2.25 OD	23
3502455 Mach Pin Link	21	6300731 Adapter	25, 27
3502457 PLT Cover	21	6300737 Hose Clamp	21
3502458 Plt Cover	21	6300763 Valve - GenFlow	19
3502459 Hose	19	6300770 Adapter	21
3502460 Hose	19	6300796 Mach Regen Manifold	23
3502461 Mach Main Shaft	7	6300883 Adapter	21
3502464 Hose	21	6301202 Flow Control Sub-Assy	25, 27
3502465 Hose	21	6310004 Flange Adapter	19
3502466 Hose	19	6310011 Adapter	19, 21, 25, 27
3502474 Wtmg Upper Jaw	5	6310049 Adapter	25, 27
		6310082 Adapter	25, 27

# INDEX

- 6310183 Adaptor 08MB-08MB 29  
6310256 Mach Port Spacer 19  
6310264 Adapter 27  
6310297 Adapter 25  
6310343 Adapter Bulkhead 25  
6350135 Swivel Manifold Assy 25, 27  
6350137 Hydraulic Cylinder 21  
6350149 Hydraulic Cylinder 19  
6360098 Rotate Manifold 25, 27  
6360106 Cyl Lock Valve 21  
6360121 Dump Valve 27  
6380083 Hydraulic Motor 25, 27  
6830050 Assy Selector Valve GRX (12V) 25  
6830056 Assy Wiring Harness 25  
6830064 Assy Wiring Harness 27  
6830065 Assy Selector Valve GRX (24V) 25, 27  
Assembly Blade Kit Cracker Jaw 5, 8, 9  
Assembly Blade Kit Pulverizer Jaw 5, 14, 15  
Assembly Body Cylinders 20, 21  
Assembly Lower Blades Shear Jaw 5, 10, 11  
Assembly Lugs 5, 16, 17  
Assembly Main Cylinder 18, 19  
Assembly Pivot Group 5, 6, 7  
Assembly Sub-Head 5, 24, 25  
Assembly Sub-Head with Dump Valve 26, 27  
Assembly Swivel Manifold 6350135 30, 31  
Assembly Upper Blades Shear Jaw 5, 12, 13  
Bar Strap 17  
Bolt Drive Specifications 40  
Bolt Torque Specifications 33, 38  
Bracket Fasteners 17  
Cap End Sleeve Bearing 31  
Cap Seal 31  
Contact Information 2, 47  
Energizer 31  
Ext Retaining Ring 31  
F0108045 Hex Head Capscrew M8 x 1.25 x 45 21  
F0108060 Hex Head Capscrew M8 x 1.25 x 60 27  
F0110020 Hex Head Capscrew M10 x 1.5 x 20 25, 27  
F0110035 Hex Head Capscrew M10 x 1.50 x 35 19, 32  
F0110040 Hex Head Capscrew M10 x 1.50 x 40 32  
F0112025 Hex Head Capscrew M12 x 1.75 x 25 21, 27  
F0112040 Hex Head Capscrew M12 x 1.75 x 40 32  
F0112050 Hex Head Capscrew M12 x 1.75 x 50 25, 27,  
32  
F0112130 Hex Head Capscrew M12 x 1.75 x 130 19  
F0114050 Hex Head Capscrew M14 x 2.00 x 50 32  
F0120260 Hex Head Capscrew M20 x 2.50 x 260 25,  
27  
F0124050 Hex Head Capscrew M24 x 3.0 x 50 25, 27  
F0127070 Hex Head Capscrew M27 x 3 x 70 15  
F0127080 Hex Head Capscrew M27 x 3 x 80 15  
F0127100 Hex Head Capscrew M27 x 3 x 100 9  
F0127120 Hex Head Capscrew M27 x 3 x 120 9  
F0127130 Hex Head Capscrew M27 x 3 x 130 25, 27  
F0127140 Hex Head Capscrew M27 x 3 x 140 9, 15  
F0127160 Hex Head Capscrew M27 x 3 x 160 9  
F0288200 Hex Head Capscrew  $\frac{7}{8}$  - 9 x 2 11  
F0288350 Hex Head Capscrew  $\frac{7}{8}$  - 9 x 3 $\frac{1}{2}$  11  
F0288450 Hex Head Capscrew  $\frac{7}{8}$  - 9 x 4 $\frac{1}{2}$  11  
F0588450 Flat Head Capscrew  $\frac{7}{8}$  - 9 x 4 $\frac{1}{2}$  11  
F0588500 Flat Head Capscrew  $\frac{7}{8}$  - 9 x 5 13  
F0588600 Flat Head Capscrew  $\frac{7}{8}$  - 9 x 6 13  
F0608075 Socket Head Capscrew M8 x 1.25 x 75 25,  
27  
F0610025 Socket Head Capscrew M10 x 1.50 x 25 25,  
27  
F0612030 Socket Head Capscrew M12 x 1.75 x 30 21  
F0612040 Socket Head Capscrew M12 x 1.75 x 40 21  
F0616170 Socket Head Capscrew M16 x 2.0 x 170 25,  
27  
F0620100 Socket Head Capscrew M20 x 2.5 x 100 19  
F0620180 Socket Head Capscrew M20 x 2.5 x 180 21  
F0624060 Socket Head Capscrew M24 x 3 x 60 7  
F0731300 Socket Head Capscrew 5/16 - 18 x 3 25, 27  
F0908809 Hex Nut  $\frac{7}{8}$  - 9 11, 13  
F1020250 Nylock Nut 21  
F1201021 Flat Washer M10 25, 27  
F1202750 Flat Washer M27 9, 15  
F1300088 Flat Washer Narrow  $\frac{7}{8}$  11, 13  
F1401000 Lock Washer M10 19, 32  
F1401200 Lock Washer M12 32  
F1401400 Lock Washer M14 32  
F1900031 Nord Lock Washer 21  
F1900050 Nord Lock Washer 19, 21, 25, 27  
F1900075 Nord Lock Washer 25, 27  
F2588088 Set Screw Socket Head  $\frac{7}{8}$  - 9 x  $\frac{7}{8}$  11  
F2802700 Hytorc Washer 25, 27  
General Arrangement 4, 5  
H0261100 Split Flange Half 1.00 Code 61 19, 32  
H0262100 Split Flange Half 1.00 Code 62 32  
H0262125 Split Flange Half 1.25 Code 62 19, 25, 27,  
32  
H0362125 Split Flange Plug 25, 27  
Head End Sleeve Bearing 31  
Hex Head Capscrew 17  
Hex Head Capscrew, M12-1.75 25  
Housing 31  
Lock Washer 31  
M12 Hi-Collar Lock Washer 31  
M12 x 1.75 x 30 C12.9 SHCS 31  
M12 x 1.75 x 35 C10.9 HHCS 31  
Mach Pin Keeper 17  
Mach Spacer Sleeve 17  
O-Ring Boss & Flat Face O-Ring Torque Specifica-  
tions 39  
Parts Order Form 43  
Parts Order Policy and Procedure 42  
Procedures 36, 37  
Regen Block Sub-Assembly 6300763 22, 23

# INDEX

S0190219 O-Ring	19, 32
S0190222 O-Ring	19, 25, 27, 32
S0190270 O-Ring	7
S0190372 O-Ring	7
Seal Kit 6300622	23
Seal Kit 6300624	23
Seal Kit 6300634	29
Seal Kit SK00024	23
Seal Kit SK00047	23
Split Flange Kits Used in This Manual	32
Spool	31
Spool Plate	31
Stick Pin Decal	17
Sub-Assembly Line Mount Manifold	28, 29
Table of Contents	3
Thread Treatment Diagram	34, 35
Torque Arm	31
U-Cup Seal	31
V-Ring Seal	31
Warranty	41
Washer	17
Wldt Link Pin	17
Wldt Stick Pin	17
Wtmg Lugs	17
Zero Leak Plug	31



**GENESIS®**

The Promise of Performance.

## CONTACT INFORMATION

### Genesis Attachments

1000 Genesis Drive  
Superior, WI 54880 USA

Toll Free: 888-SHEAR-IT  
(888-743-2748)

Phone: 715.395.5252

E-mail:  
info@genesisattachments.com

### Europe/Africa/Middle East Genesis GmbH

Teramostrasse 23  
87700 Memmingen, Germany

Phone: +49 83 31 9 25 98 0

Fax: +49 83 31 9 25 98 80

genesis-europe.com

E-mail:  
info@genesis-europe.com

### Asia Pacific Representative Office

24 Upper Serangoon View #12-28  
Singapore 534205

Phone: +65 9673 9730

E-mail:  
tchoo@genesisattachments.com

### Central America & Colombia

Cra 13A #89-38 / Ofi 613  
Bogota, Colombia

Phone: +57 1 610 8160 / 795 8747

E-mail:  
contact@themsagroup.com

View and download all manuals: [genesisattachments.com/manuals](http://genesisattachments.com/manuals)

Patents: [genesisattachments.com/products/patents](http://genesisattachments.com/products/patents)