

GENESIS[®]

The Promise of Performance.

GRP 480 Rebar Processor

PARTS MANUAL



CONTACT INFORMATION

Genesis Attachments

1000 Genesis Drive
Superior, WI 54880 USA

Toll Free: 888-SHEAR-IT
(888-743-2748)

Phone: 715.395.5252

E-mail:
info@genesisattachments.com

Europe/Africa/Middle East Genesis GmbH

Teramostrasse 23
87700 Memmingen, Germany

Phone: +49 83 31 9 25 98 0
Fax: +49 83 31 9 25 98 80
genesis-europe.com

E-mail:
info@genesis-europe.com

Asia Pacific Representative Office

24 Upper Serangoon View #12-28
Singapore 534205

Phone: +65 9673 9730

E-mail:
tchoo@genesisattachments.com

Central America & Colombia

Cra 13A #89-38 / Ofi 613
Bogota, Colombia

Phone: +57 1 610 8160 / 795 8747

E-mail:
contact@themsagroup.com

View and download all manuals: genesisattachments.com/manuals
Patents: genesisattachments.com/products/patents

TABLE OF CONTENTS

CONTACT INFORMATION	2
GENERAL ARRANGEMENT	4
ASSEMBLY PIVOT GROUP - RIGHT SIDE	6
ASSEMBLY PIVOT GROUP - LEFT SIDE	8
ASSEMBLY LOWER BLADES	10
ASSEMBLY UPPER BLADES & WEAR PLATE	12
ASSEMBLY AUTO GUIDES	14
ASSEMBLY CYLINDER PINS	16
ASSEMBLY ACCESS COVERS	18
ASSEMBLY UPPER HEAD - SECOND-MEMBER	20
ASSEMBLY UPPER HEAD - THIRD-MEMBER	22
ASSEMBLY LUGS FOR FLATTOP HEAD	24
ASSEMBLY ROTATION	26
ASSEMBLY ROTATION CIRCUIT	28
SUB-ASSEMBLY LINE MOUNT MANIFOLD - 6302659	30
ASSEMBLY OPEN AND CLOSE CIRCUIT	32
ASSEMBLY SWIVEL MANIFOLD	34
REGEN BLOCK SUB-ASSEMBLY - 6360021	36
ASSEMBLY SLEWING RING LUBRICATION	38
BOLT TORQUE SPECIFICATIONS	40
THREAD TREATMENT DIAGRAM	41
Mobile Shears.....	41
PROCEDURES	42
Cleaning.....	42
Threadlocker.....	42
Anti-Seize.....	43
No Thread Treatment.....	43
BOLT TORQUE SPECIFICATIONS	44
Dry Torque Values.....	44
Wet Torque Values.....	44
O-RING BOSS & FLAT FACE O-RING TORQUE SPECIFICATIONS	45
BOLT DRIVE SPECIFICATIONS	46
WARRANTY	47
Claim Procedure.....	47
Blade Warranty.....	47
PARTS ORDER POLICY AND PROCEDURE	48
Parts Orders Should Include.....	48
Placing Orders.....	48
Part Numbers.....	48
Shipping.....	48
Invoices.....	48
Returns.....	48
Warranty Returns.....	48
PARTS ORDER FORM	49
INDEX	50
CONTACT INFORMATION	52

GENERAL ARRANGEMENT

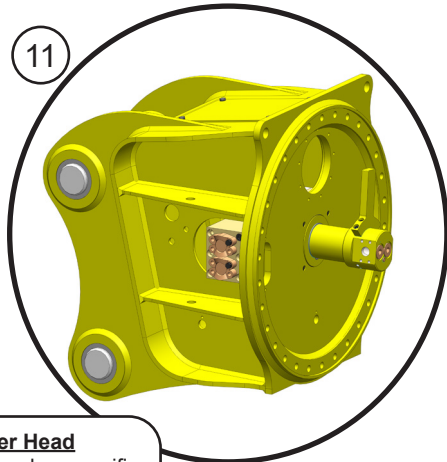
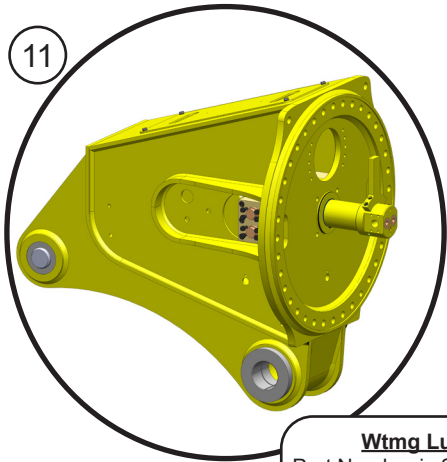
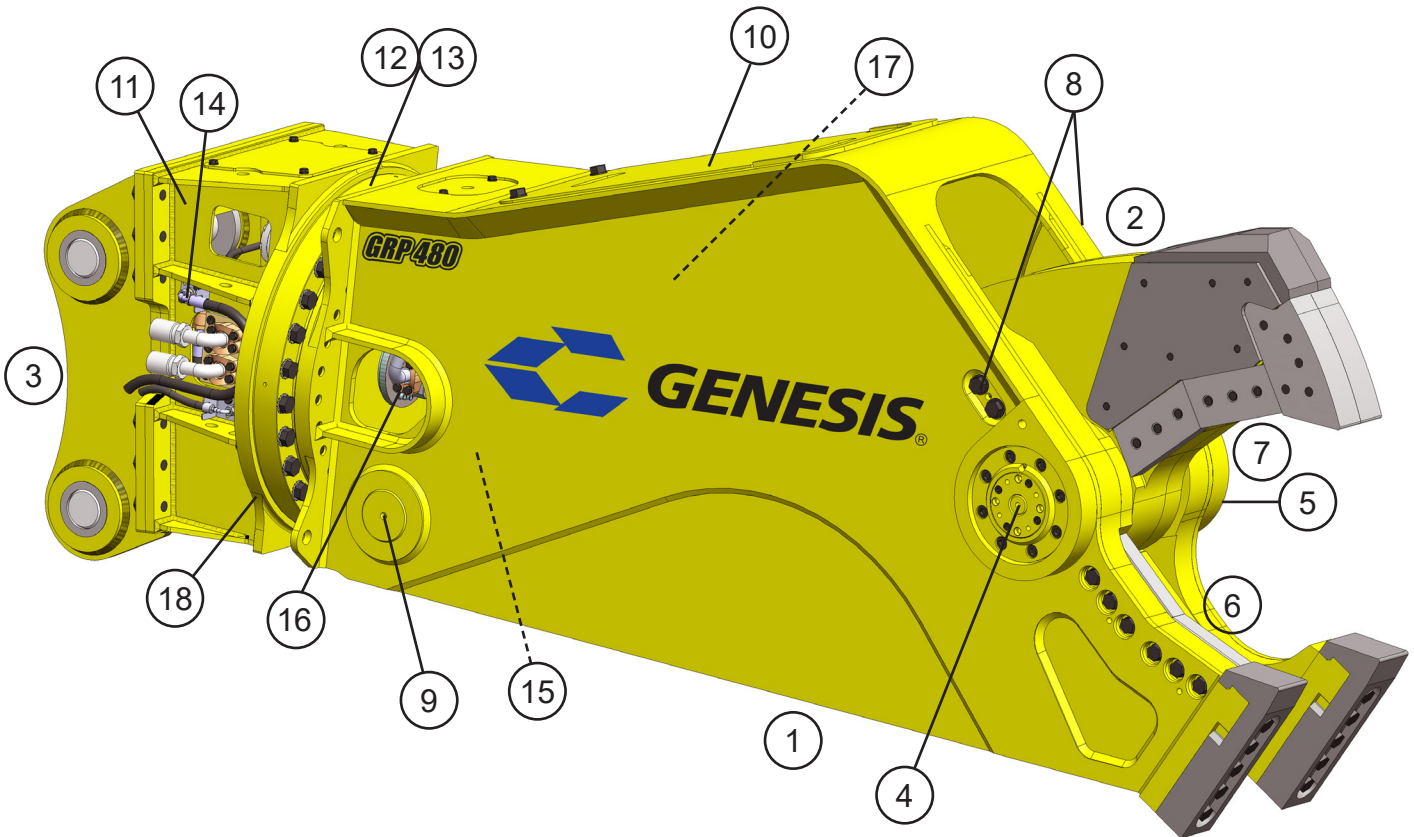

Wtmg Lug Upper Head
 Part Number is Serial Number specific.
 For replacement parts call the Genesis
 Parts Department.

USA	Europe
715-395-3488	+49 83 31 9 25 98 0



GENERAL ARRANGEMENT

ITEM	QTY	PART NUMBER	DESCRIPTION
1	1	*	Wtmg Stick
2	1	*	Wtmg Upper
3		*	Assembly Lugs for Flat-top Head
4		See page 6	Assembly Pivot Group - Right Side
5		See page 8	Assembly Pivot Group - Left Side
6		See page 10	Assembly Lower Blades
7		See page 12	Assembly Upper Blades & Wear Plate
8		See page 14	Assembly Auto Guides
9		See page 16	Assembly Cylinder Pins
10		See page 18	Assembly Access Covers
11		See page 20 - page 23	Assembly Upper Head Second-Member/Third-Member
12		See page 26	Assembly Rotation
13		See page 28	Assembly Rotation Circuit
14		See page 30	Sub-Assembly Line Mount Manifold
15		See page 32	Assembly Open and Close Circuit
16		See page 34	Assembly Swivel Manifold
17		See page 36	Sub-Assembly Regen Block
18		See page 38	Assembly Slewing Ring Lubrication

* Part numbers are Serial Number specific. For replacement parts call the Genesis Parts Department.

USA

715-395-3488

Europe

+49 83 31 9 25 98 0

ASSEMBLY PIVOT GROUP - RIGHT SIDE

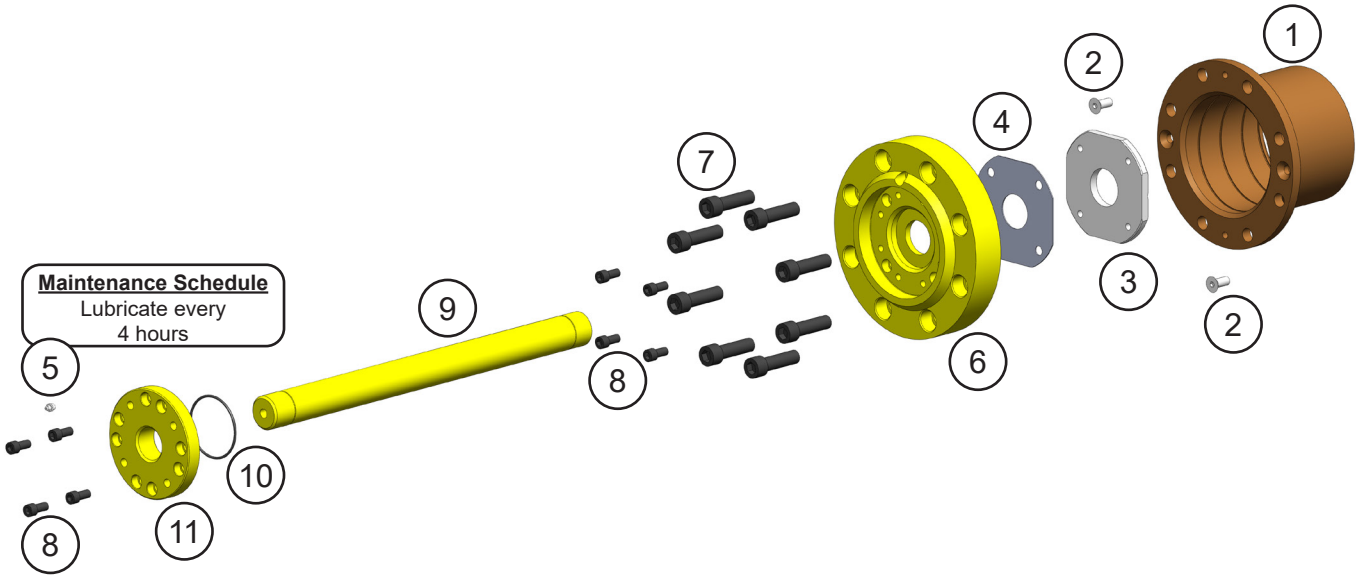

ASSEMBLY PIVOT GROUP - RIGHT SIDE

ITEM	QTY	PART NUMBER	DESCRIPTION
1	1	1109586	Mach Bearing RH
2	2	F0412030	Flat Head Capscrew M12 x 1.75 x 30
3	1	1109592	Mach Thrust Washer
4	1	1109594	Shim Set Thrust Washer
5	1	6200002	Grease Fitting
6	1	1109588	Mach End Cap
7	8	F0620070	Socket Head Capscrew M20 x 2.50 x 70
8	8	F0612025	Socket Head Capscrew M12 x 1.75 x 25
9	1	1109593	Mach Tie Rod
10	1	S0190238	O-Ring
11	1	1106542	Mach Tie Rod Nut

ASSEMBLY PIVOT GROUP - LEFT SIDE

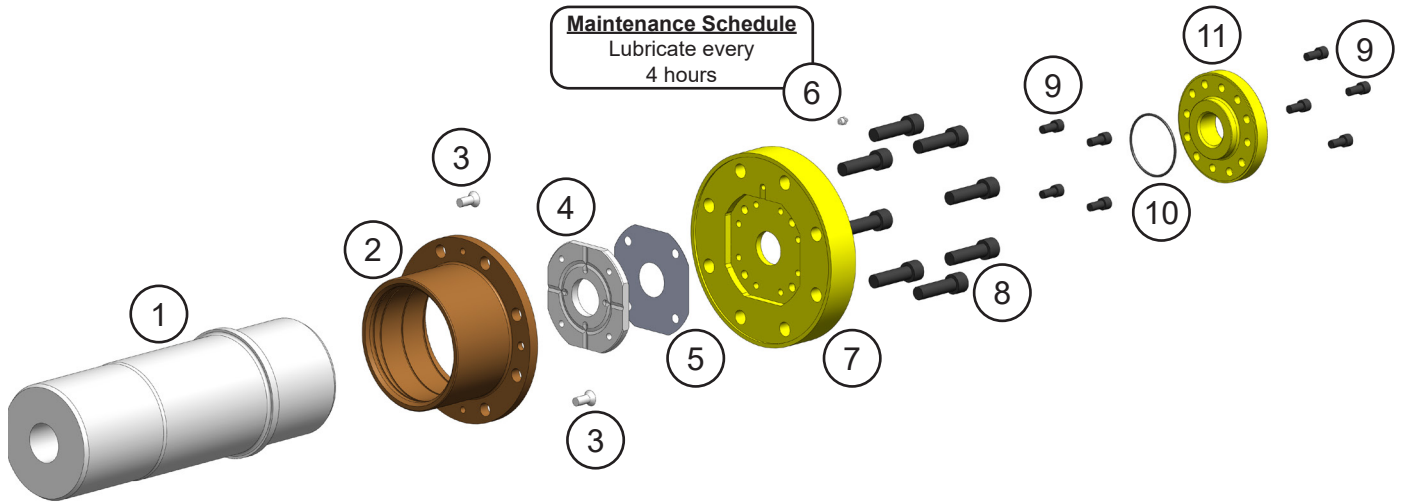

ASSEMBLY PIVOT GROUP - LEFT SIDE

ITEM	QTY	PART NUMBER	DESCRIPTION
1	1	1109595	Mach Main Shaft
2	1	1109587	Mach Bearing LH
3	2	F0412030	Flat Head Capscrew M12 x 1.75 x 30
4	1	1109592	Mach Thrust Washer
5	1	1109594	Shim Set Thrust Washer
6	1	6200002	Grease Fitting
7	1	1109588	Mach End Cap
8	8	F0620070	Socket Head Capscrew M20 x 2.50 x 70
9	4	F0612025	Socket Head Capscrew M12 x 1.75 x 25
10	1	S0190238	O-Ring
11	1	1109590	Mach Tie Rod Nut

ASSEMBLY LOWER BLADES

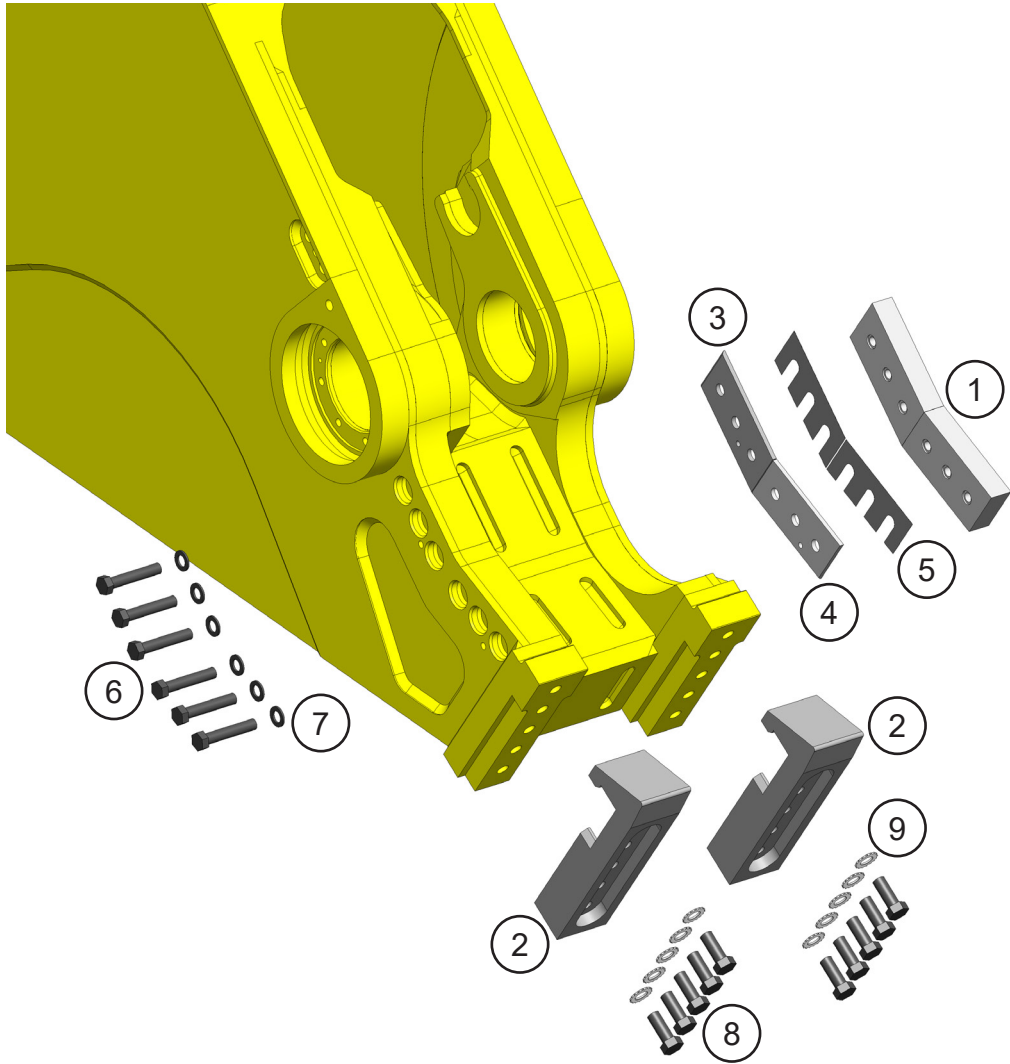

ASSEMBLY LOWER BLADES

ITEM	QTY	PART NUMBER	DESCRIPTION
1	2	3503690	Mach Blade
2	1	1109599	Mach Tusk
3	1	1109621	Mach Adjust Plate Primary
4	1	1109623	Mach Adjust Plate Secondary
5	2	3502808	Blade Shim Set
6	6	F0124130	Hex Head Capscrew M24 x 3 x 130
7	6	F1202444	Flat Washer M24
8	10	F0127070	Hex Head Capscrew M27
9	10	F2802700	Hytorc Reaction Washer M27

ASSEMBLY UPPER BLADES & WEAR PLATE

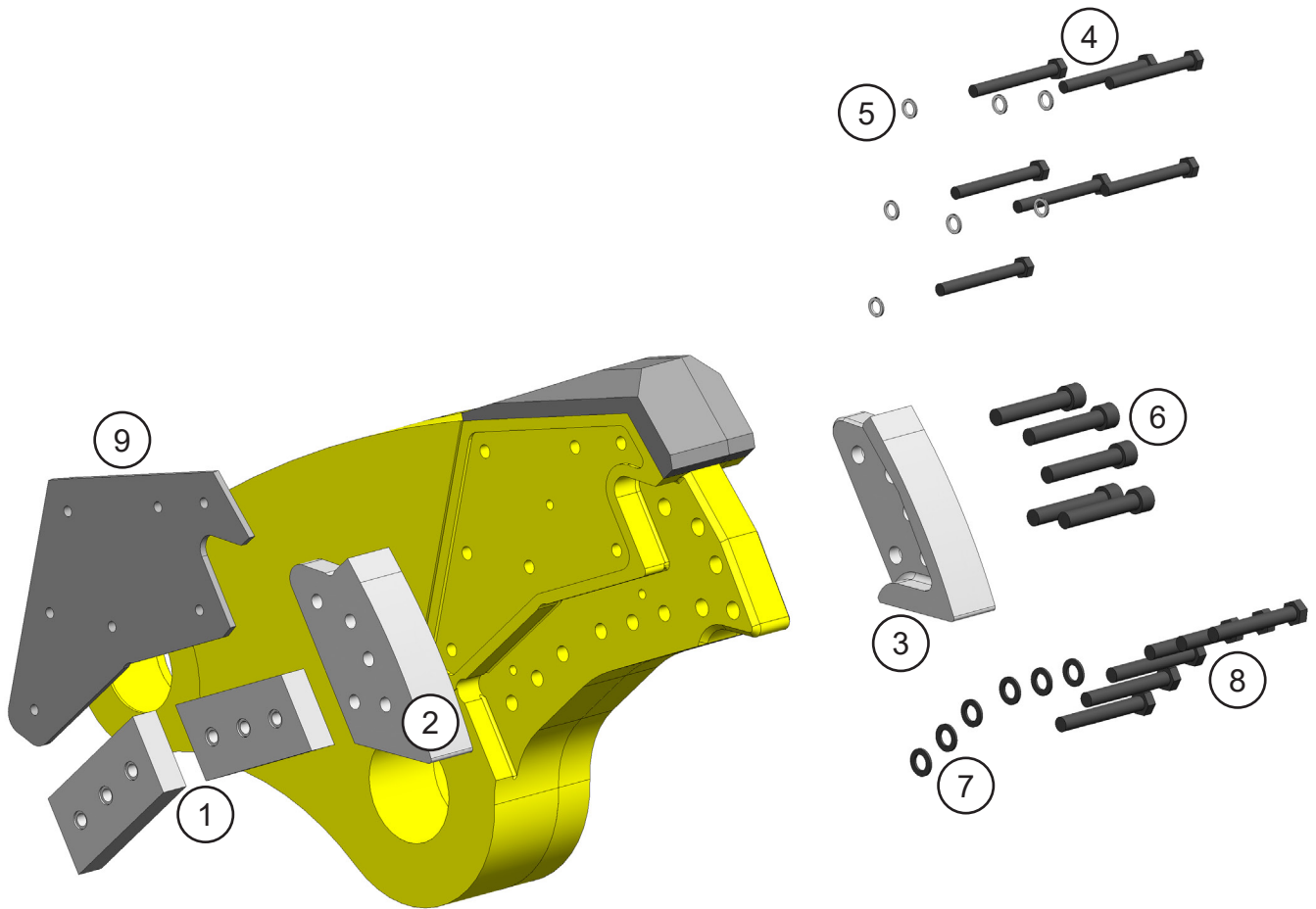

ASSEMBLY UPPER BLADES & WEAR PLATE

ITEM	QTY	PART NUMBER	DESCRIPTION
1	2	3503690	Mach Blade
2	1	1109612	Mach Blade Tip Right
3	1	1109611	Mach Blade Tip Left
4	7	F0120180	Hex Head Capscrew M20 x 2.5 x 180
5	7	F1900075	Washer M20
6	5	F0627155	Socket Head Capscrew M20
7	6	F1202444	Flat Washer M24
8	6	F0124175	Hex Head Capscrew M24 x 3 x 175
9	1	1109618	Mach Upper Side Wear Plt

ASSEMBLY AUTO GUIDES

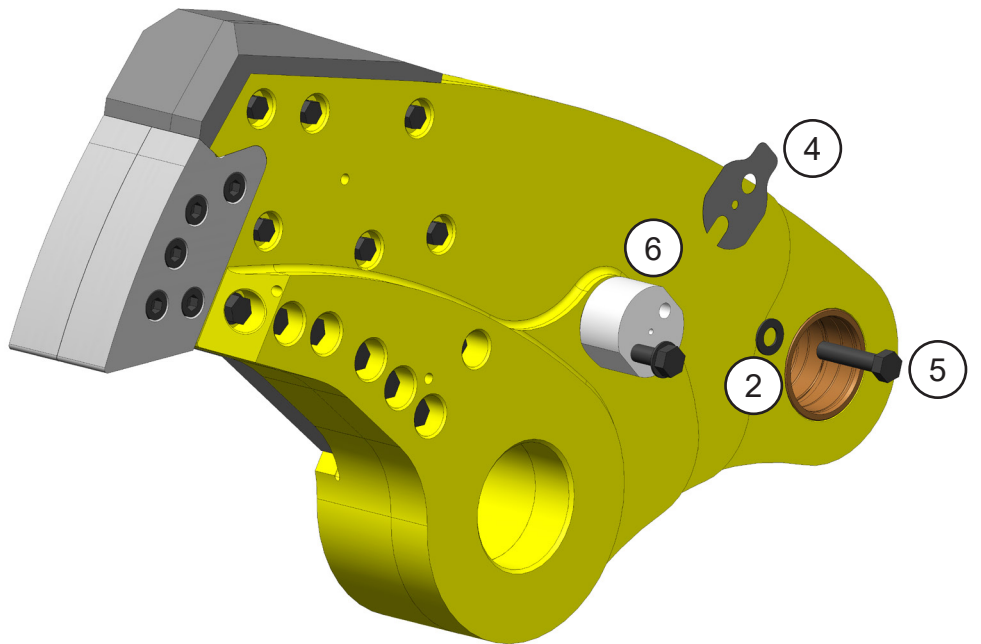
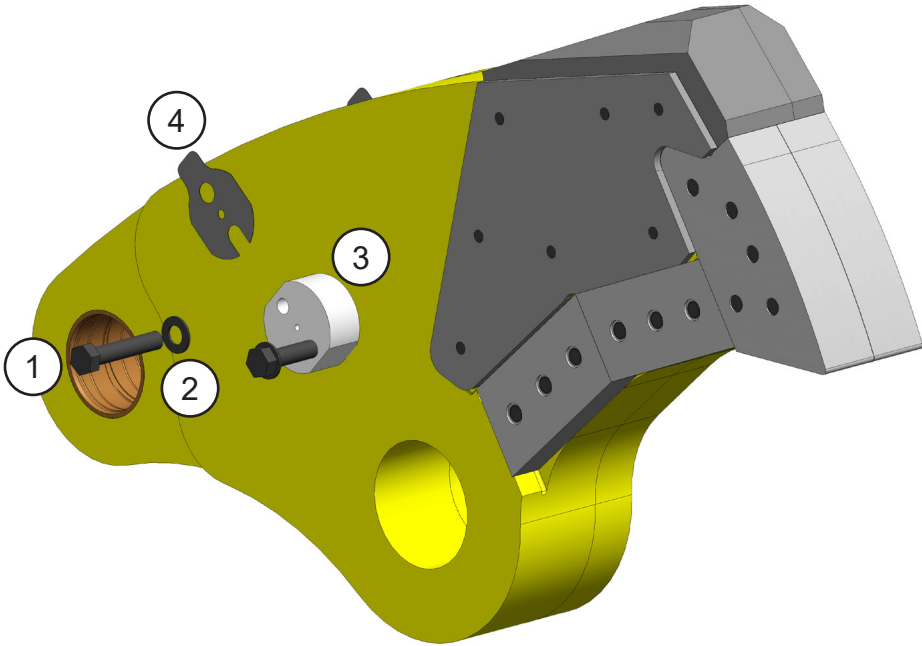

ASSEMBLY AUTO GUIDES

ITEM	QTY	PART NUMBER	DESCRIPTION
1	2	F0210500	Hex Head Capscrew 1 - 8 x 5
2	2	F1300100	Flat Washer Narrow 1"
3	1	*	Mach Auto Guide - Blade Side
4	2	1106478	Shim Set, Auto Guide
5	2	50210450	Hex Head Capscrew 1 - 8 x 4.50
6	1	*	Mach Auto Guide - Guide Side

* Part numbers are Serial Number specific. For replacement parts call the Genesis Parts Department.

USA

715-395-3488

Europe

+49 83 31 9 25 98 0

ASSEMBLY CYLINDER PINS

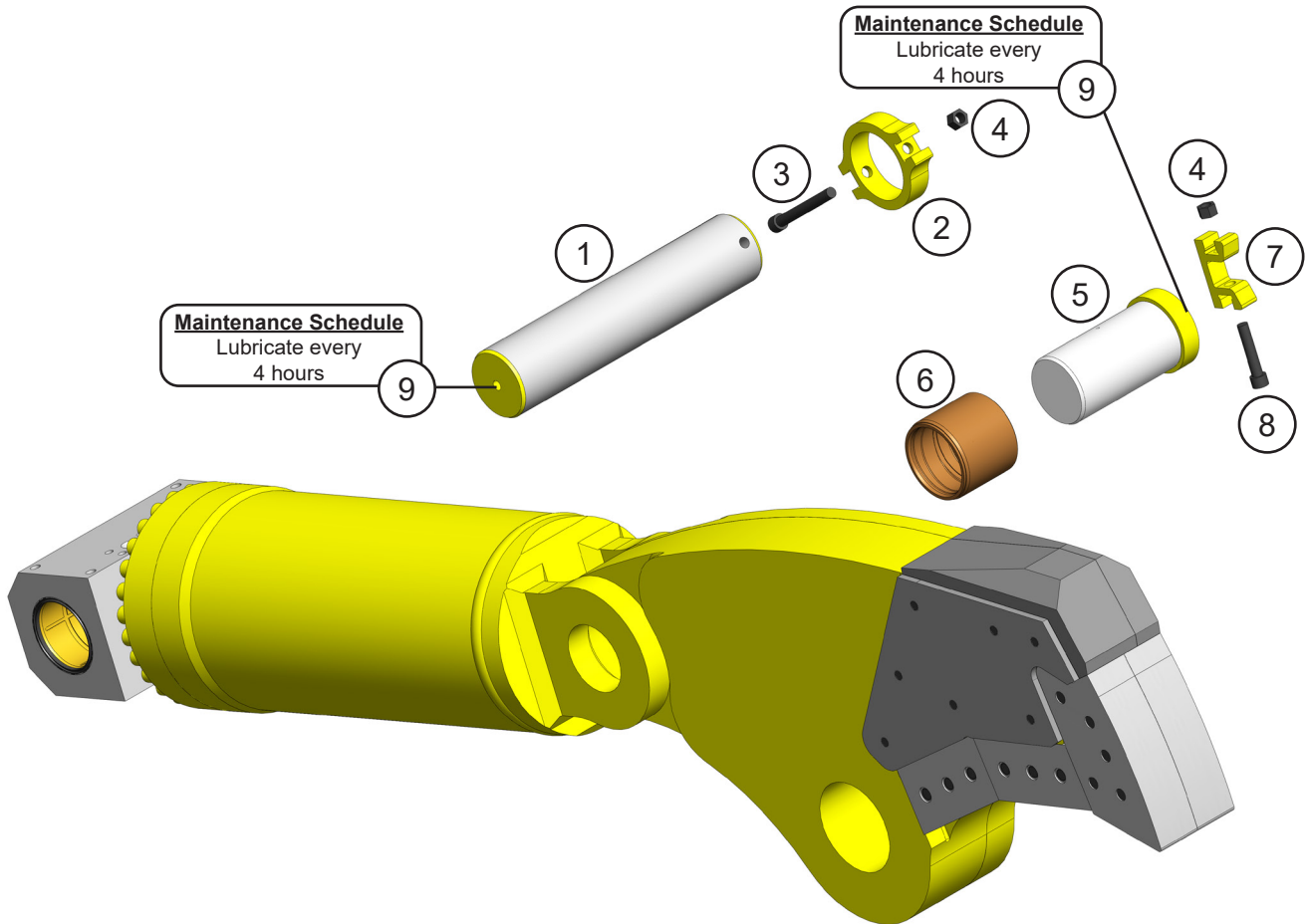

ASSEMBLY CYLINDER PINS

ITEM	QTY	PART NUMBER	DESCRIPTION
1	1	1109142	Mach Rear Cyl Pin
2	1	1106571	Mach Pin Keeper Rear
3	1	F0620180	Socket Head Capscrew M20 x 2.50 x 180
4	2	F1020250	Nylock Hex Nut M20 x 2.50
5	1	1106546	Wldt Front Cyl Pin
6	1	1106592	Mach Bearing Upper Cylinder Connection
7	1	3500350	Mach Pin Keeper (Clevis)
8	1	F0620100	Socket Head Capscrew M20 x 2.50 x 100
9	2	6200002	Grease Fitting

ASSEMBLY ACCESS COVERS

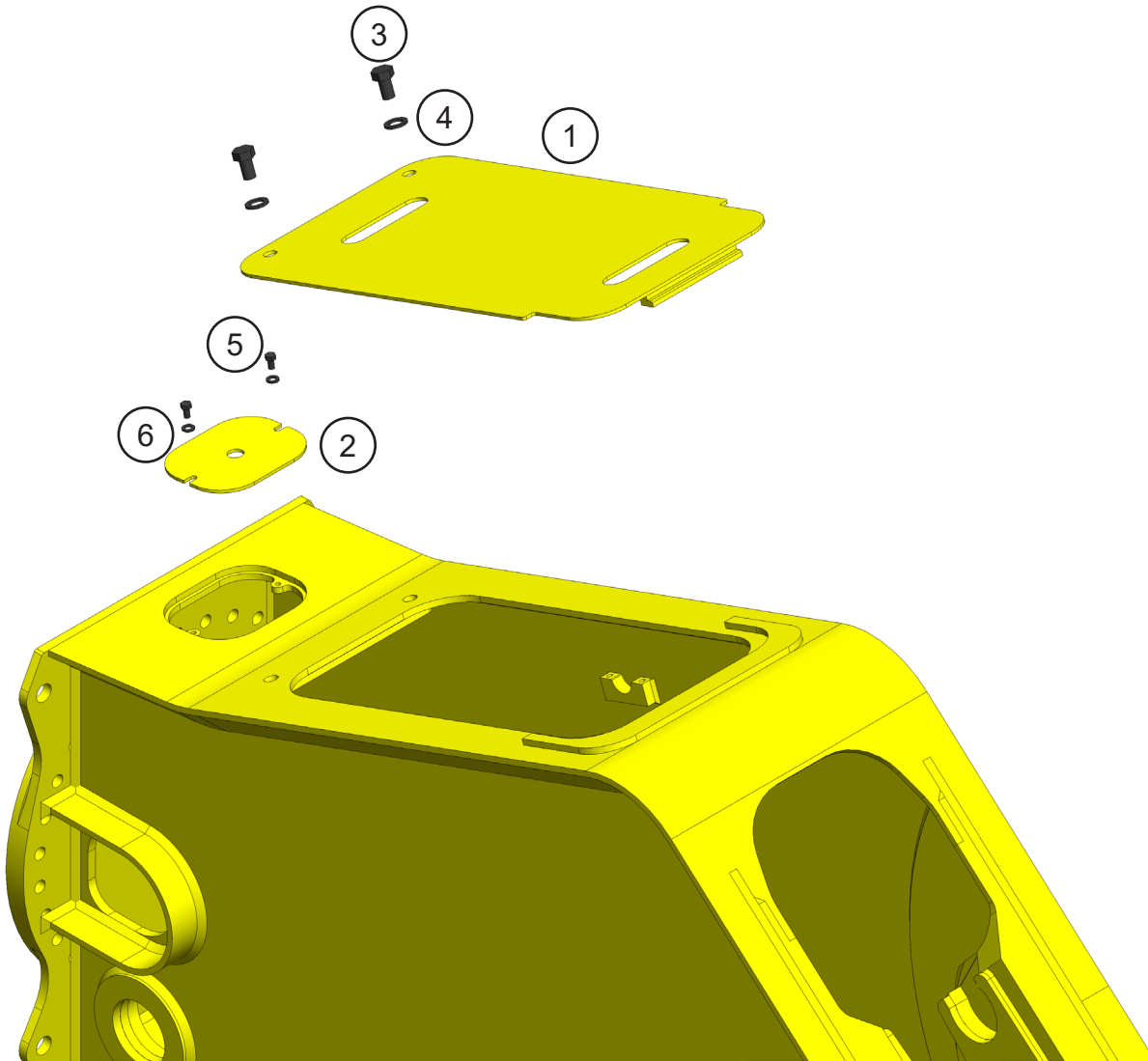

ASSEMBLY ACCESS COVERS

ITEM	QTY	PART NUMBER	DESCRIPTION
1	1	1109632	Wldt Cover
2	1	1109143	Plt Rear Cover
3	2	F0124040	Hex Head Capscrew M24 x 3 x 40
4	2	F1202444	Flat Washer M24
5	2	F0112020	Hex Head Capscrew M12 x 1.75 x 20
6	2	F1201224	Flat Washer M12

ASSEMBLY UPPER HEAD - SECOND-MEMBER

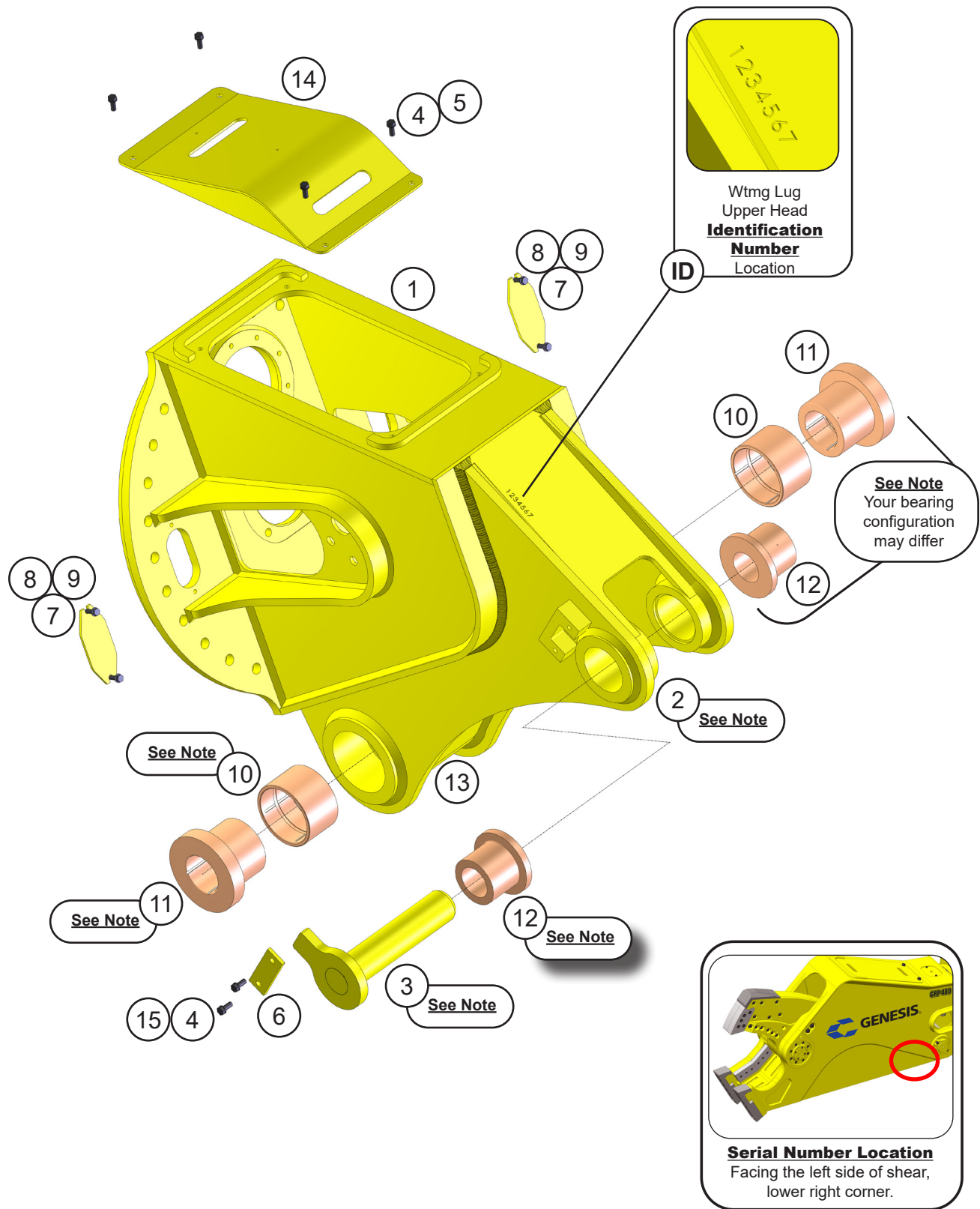

ASSEMBLY UPPER HEAD - SECOND-MEMBER

ITEM	QTY	PART NUMBER	DESCRIPTION
1	1	*	Wtmg Sub Head
2	1	*	Wtmg Lug Upper Head
3	1	*	Wldt Pin
4	6	F0112030	Hex Head Capscrew M12 x 1.75 x 30
5	4	F1201224	Flat Washer M12
6	1	5500752	Plt Strap
7	2	1105883	Plt Bolt Cover
8	4	F0110030	Hex Head Capscrew M10 x 1.50 x 30
9	4	F1201021	Flat Washer M10
10	2	*	Mach Bearing
11	2	*	Mach Boom Bearing
12	2	*	Mach Spacer Sleeve
13	1	6200002	Grease Fitting
14	2	1105878	Wtmg Sub Head Cover
15	2	F1401200	Lock Washer M12

* Part numbers are Serial Number specific. For replacement parts call the Genesis Parts Department.

USA

715-395-3488

Europe

+49 83 31 9 25 98 0

ASSEMBLY UPPER HEAD - THIRD-MEMBER

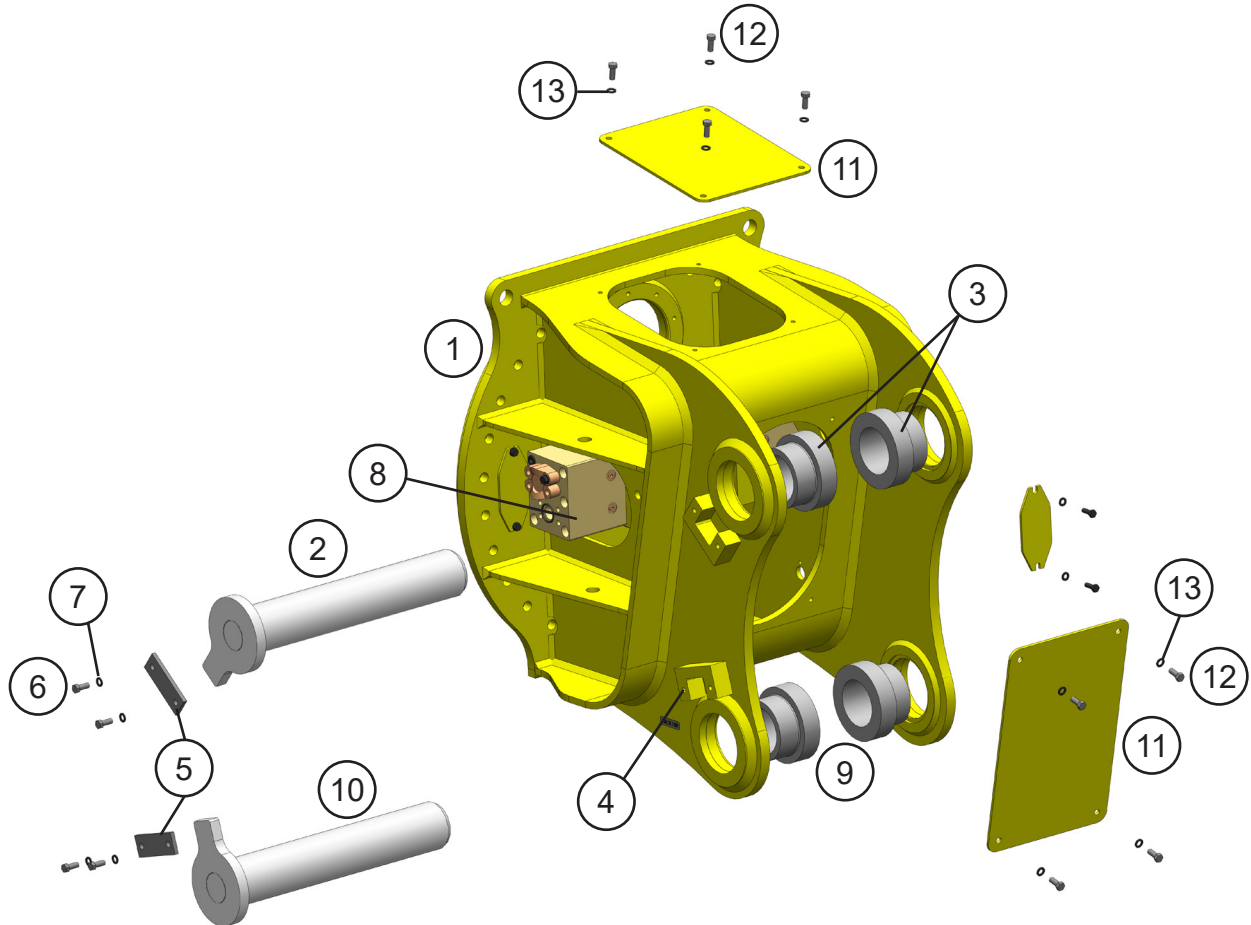

ASSEMBLY UPPER HEAD - THIRD-MEMBER

ITEM	QTY	PART NUMBER	DESCRIPTION
1	1	**	Upper Head
2	1	**	Cylinder Link Pin
3	*	**	Spacer Sleeves, Cylinder Link Pin
4	2	**	Pin Keeper
5	2	**	Strap
6	4	**	Hex Head Capscrew
7	4	**	Lock Washer
8	1	**	Port Block Assembly
9	*	**	Bearings and/or Spacer Sleeves, where used
10	1	**	Stick Pin
11	1	**	Inspection/Access Cover
12	4	**	Hex Head Capscrew
13	4	**	Flat Washer

* Quantity is dependent upon the bracket.

** Part numbers are Serial Number specific. For replacement parts call the Genesis Parts Department.

USA

715-395-3488

Europe

+49 83 31 9 25 98 0

ASSEMBLY LUGS FOR FLATTOP HEAD

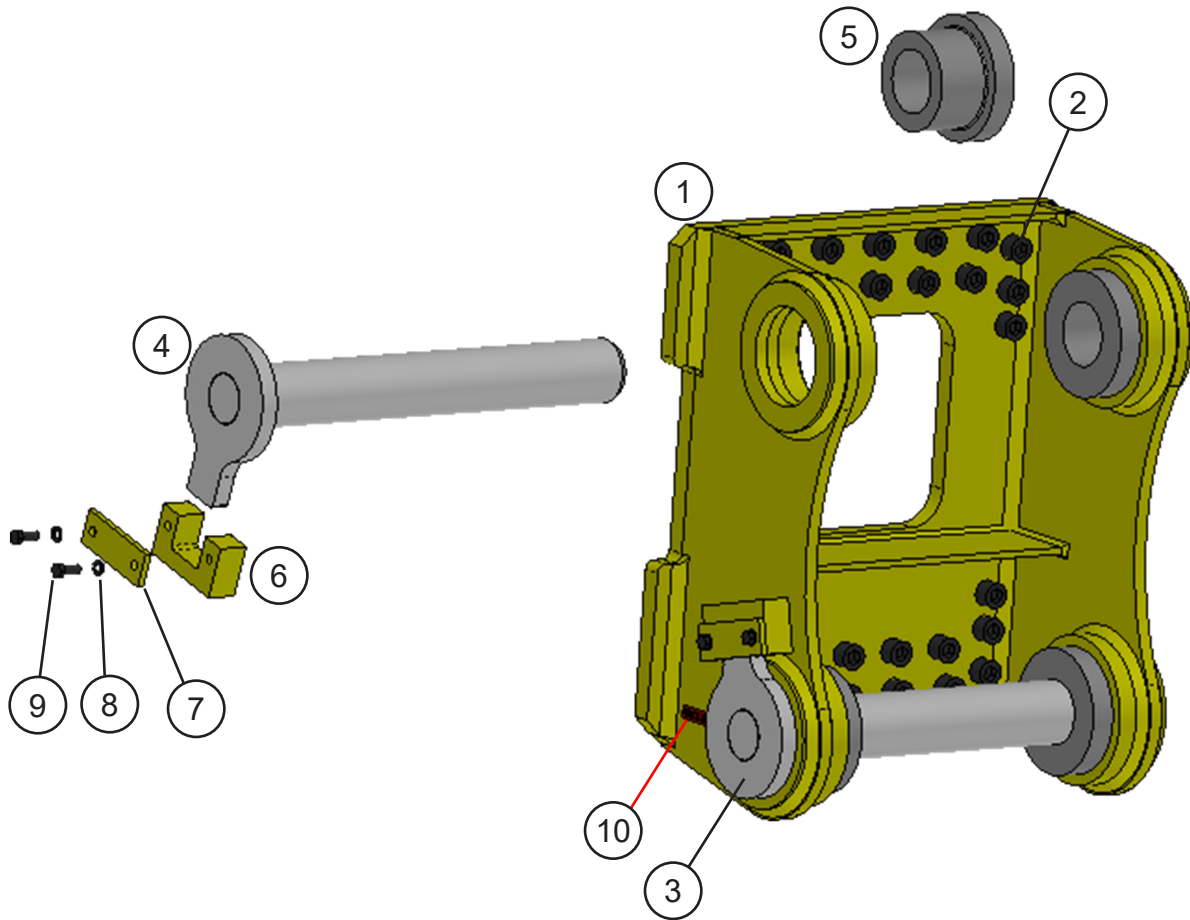

ASSEMBLY LUGS FOR FLATTOP HEAD

ITEM	QTY	PART NUMBER	DESCRIPTION
1	1	**	Wtmg Lugs
2	*	**	Bracket Fasteners
3	1	**	Wldt Stick Pin
4	1	**	Wldt Link Pin
5	*	**	Mach Spacer Sleeve
6	2	**	Mach Pin Keeper
7	2	**	Bar Strap
8	4	**	Washer
9	4	**	Hex Head Capscrew
10	1	**	Stick Pin Decal

* Quantity is dependent upon the bracket.

** Part numbers are Serial Number specific. For replacement parts call the Genesis Parts Department.

USA

715-395-3488

Europe

+49 83 31 9 25 98 0

ASSEMBLY ROTATION

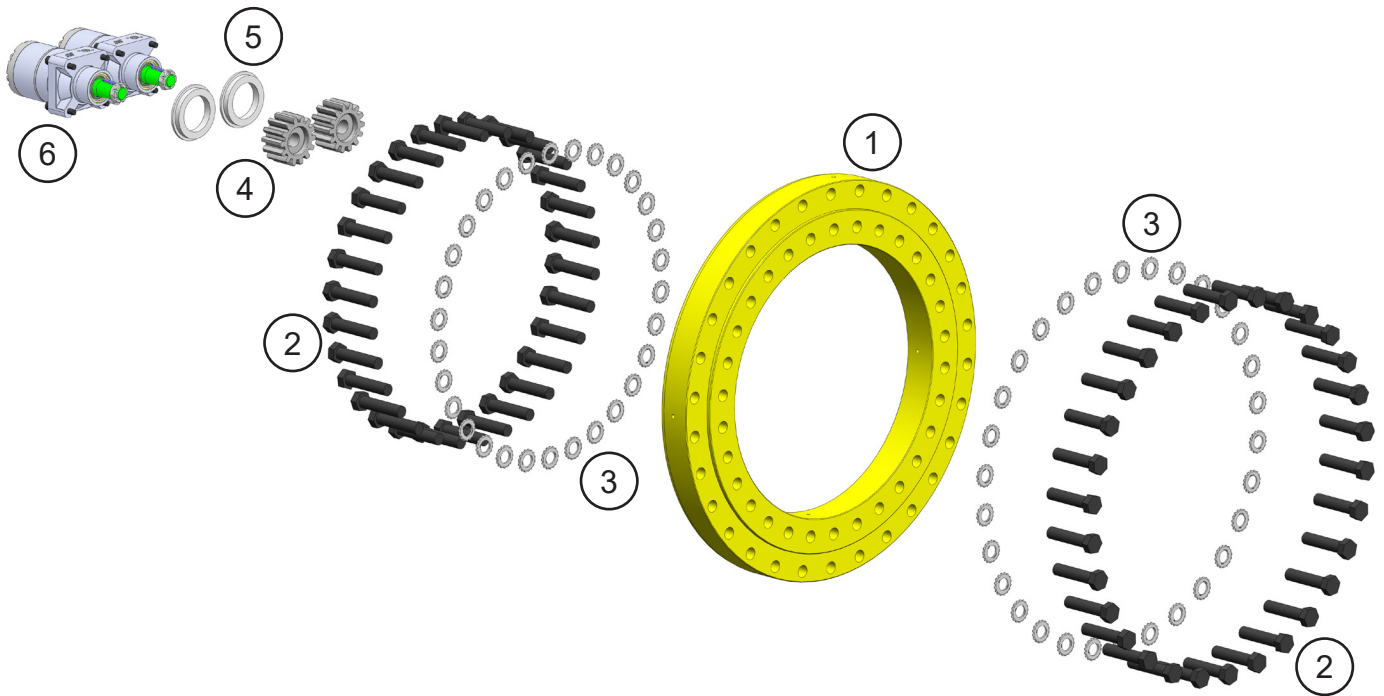

ASSEMBLY ROTATION

ITEM	QTY	PART NUMBER	DESCRIPTION
1	1	6300429	Bearing Slewing
2	60	F0127120	Hex Head Capscrew M27 x 3 x 120
3	60	F2802700	Hytorc Washer
4	2	3101235	Pinion Gear, Tapered Shaft
5	2	3501835	Mach Spacer
6	2	6380090	Motor

ASSEMBLY ROTATION CIRCUIT

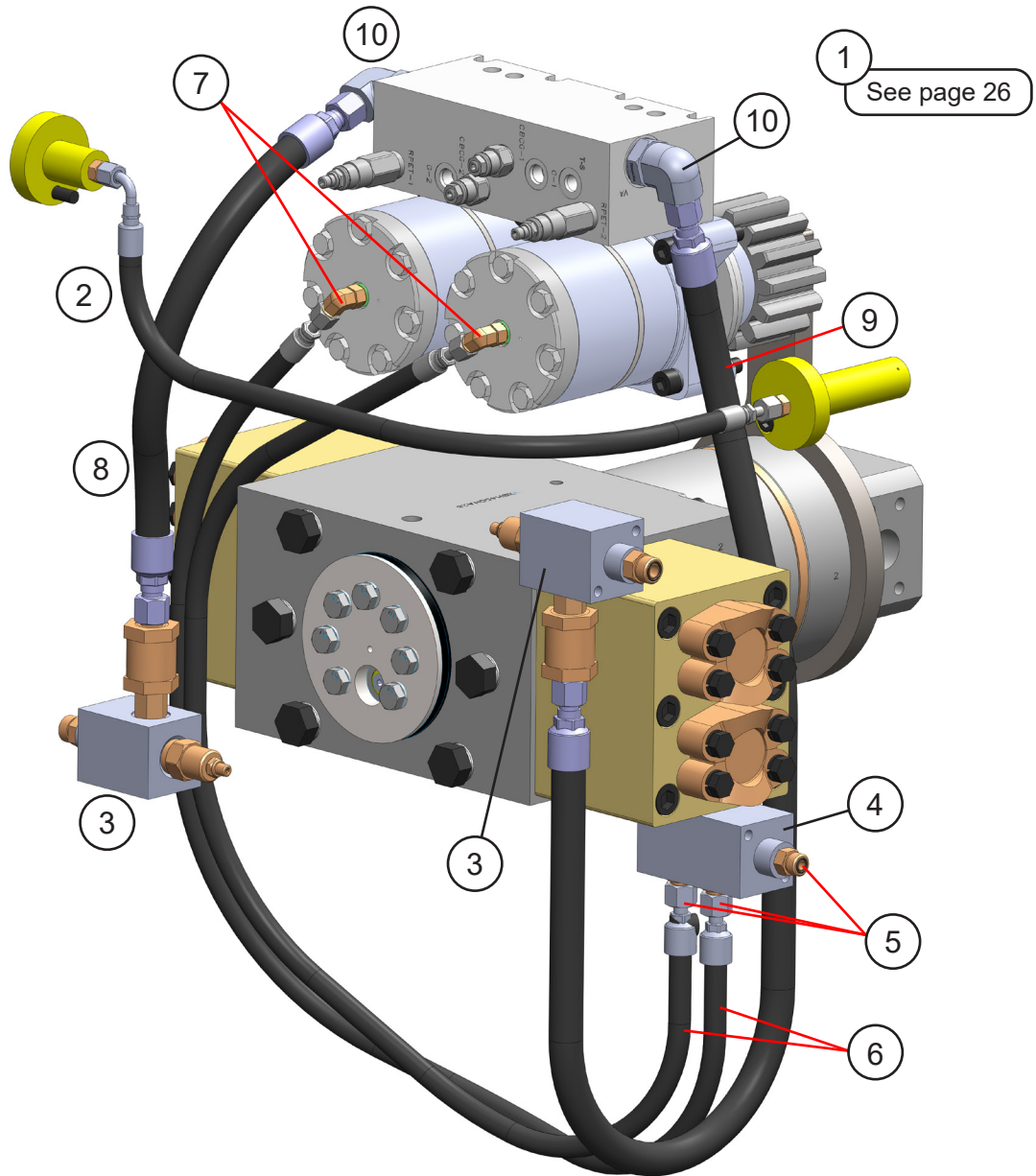

ASSEMBLY ROTATION CIRCUIT

ITEM	QTY	PART NUMBER	DESCRIPTION
1	1	See page 26	Assembly Rotation
2	1	See page 38	Assembly Slewing Ring Lubrication
3	2	See page 30	Sub-Assembly Line Mount Manifold
4	1	6302661	Case Drain Manifold
5	3	6300018	Adapter 06MB-06MO
6	2	5517832	Hose
7	2	6300768	Adapter 04MB-04MO-90
8	1	5517828	Hose
9	1	5517829	Hose
10	2	6310082	Adapter 12MB-08MO-90

SUB-ASSEMBLY LINE MOUNT MANIFOLD - 6302659

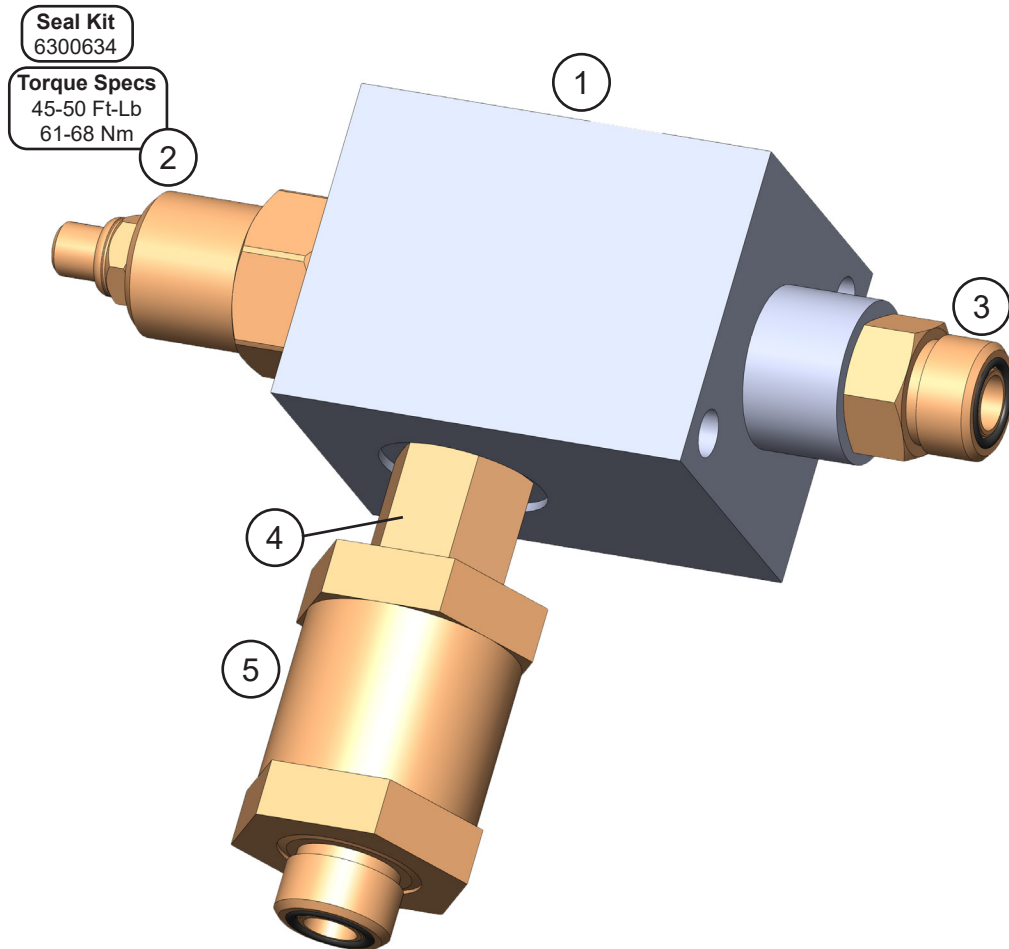

SUB-ASSEMBLY LINE MOUNT MANIFOLD - 6302659

ITEM	QTY	PART NUMBER	DESCRIPTION
1	1	6302658	Valve Line Body
2	1	6300361	Valve Flow Control Seal Kit 6300634
3	1	6310050	Adapter 08MB-08MO
4	1	6310183	Adapter 08MB-08MB
5	1	6300364	Filter

ASSEMBLY OPEN AND CLOSE CIRCUIT

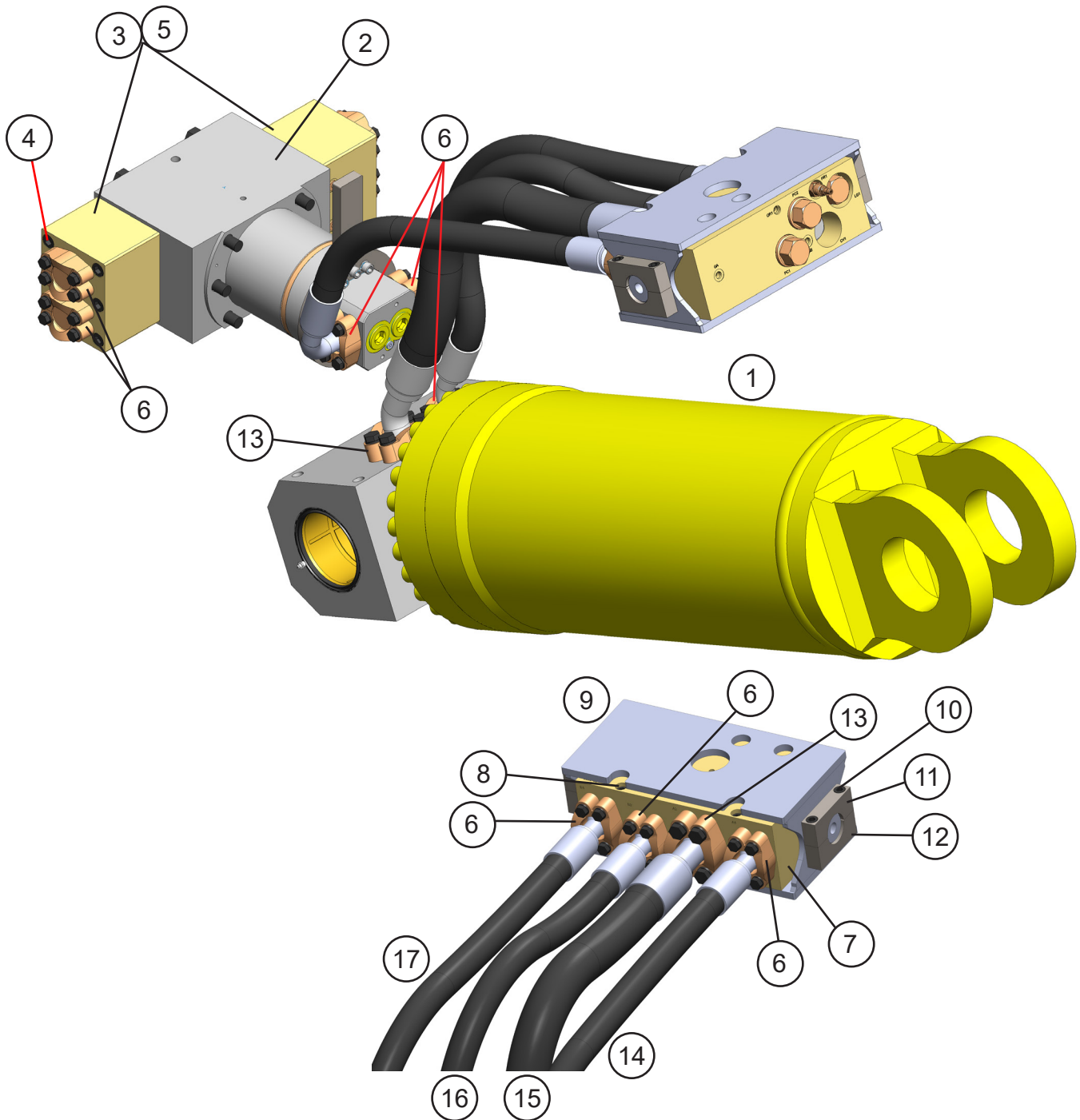

ASSEMBLY OPEN AND CLOSE CIRCUIT

ITEM	QTY	PART NUMBER	DESCRIPTION
1	1	*	Assembly Cylinder B13.0 R8.5 S26.00
2	1	See page 34	Assembly Swivel Manifold
3	2	*	Mach Port Block
4	12	F0616130	Socket Head Capscrew M16 x 2 x 130
5	4	*	O-Ring
6	10	1-1/4" Split Flange Kit	
	2	H0262125	Split Flange Half 1.25 Code 62
	4	F0112050	Hex Head Capscrew M12 x 1.75 x 50
	4	F1401200	Lock Washer M12
	1	S0190222	O-Ring
7	1	See page 36	Valve Regen
8	4	F0612120	Socket Head Capscrew M12 x 1.75 x 120
9	1	1109201	Wldt Pivot Valve Tray
10	2	F0612055	Socket Head Capscrew M12 x 1.75 x 55
11	2	1109210	Upper Regen Tray Bar
12	2	1109209	Lower Regen Tray Bar
13	2	1-1/2" Split Flange Kit	
	2	H0262150	Split Flange Half 1.50 Code 62
	4	F0116060	Hex Head Capscrew M16 x 2.00 x 60
	4	F1401628	Lock Washer M16
	1	S0190225	O-Ring
14	1	1109637	Hose
15	1	1109639	Hose
16	1	1109638	Hose
17	1	1109636	Hose

* Part numbers are Serial Number specific. For replacement parts call the Genesis Parts Department.

USA
715-395-3488

Europe
+49 83 31 9 25 98 0

ASSEMBLY SWIVEL MANIFOLD

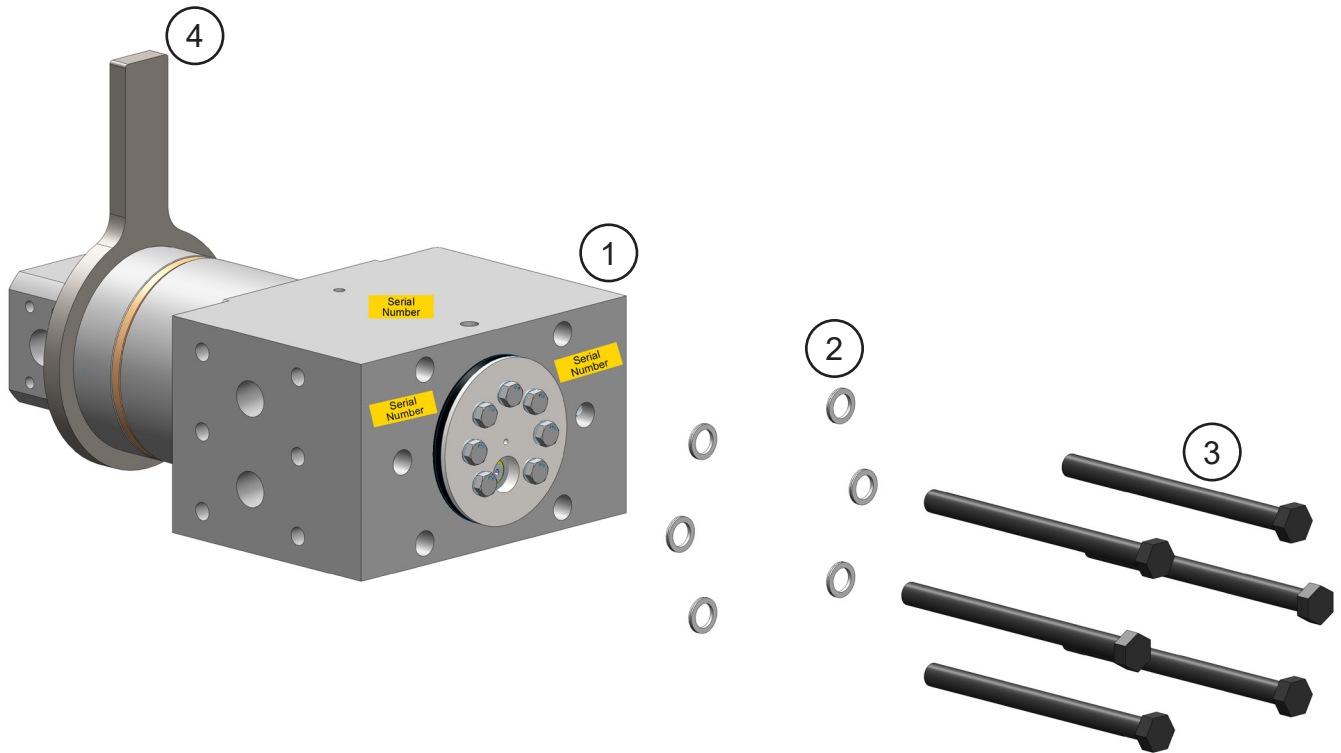

ASSEMBLY SWIVEL MANIFOLD

ITEM	QTY	PART NUMBER	DESCRIPTION
1	1	*	Assembly Swivel Manifold
2	6	F1900075	Wedge Lock Washer ¾
3	6	F0120260	Hex Head Capscrew M20 x 2.5 x 260
4	1	*	Torque Arm Kit

* Part numbers are Serial Number specific.

For replacement parts and seal kit, call the Genesis Parts Department.

The swivel Serial Number, located in one of the three highlighted areas, is required for **any** parts order.

USA

715-395-3488

Europe

+49 83 31 9 25 98 0

REGEN BLOCK SUB-ASSEMBLY - 6360021

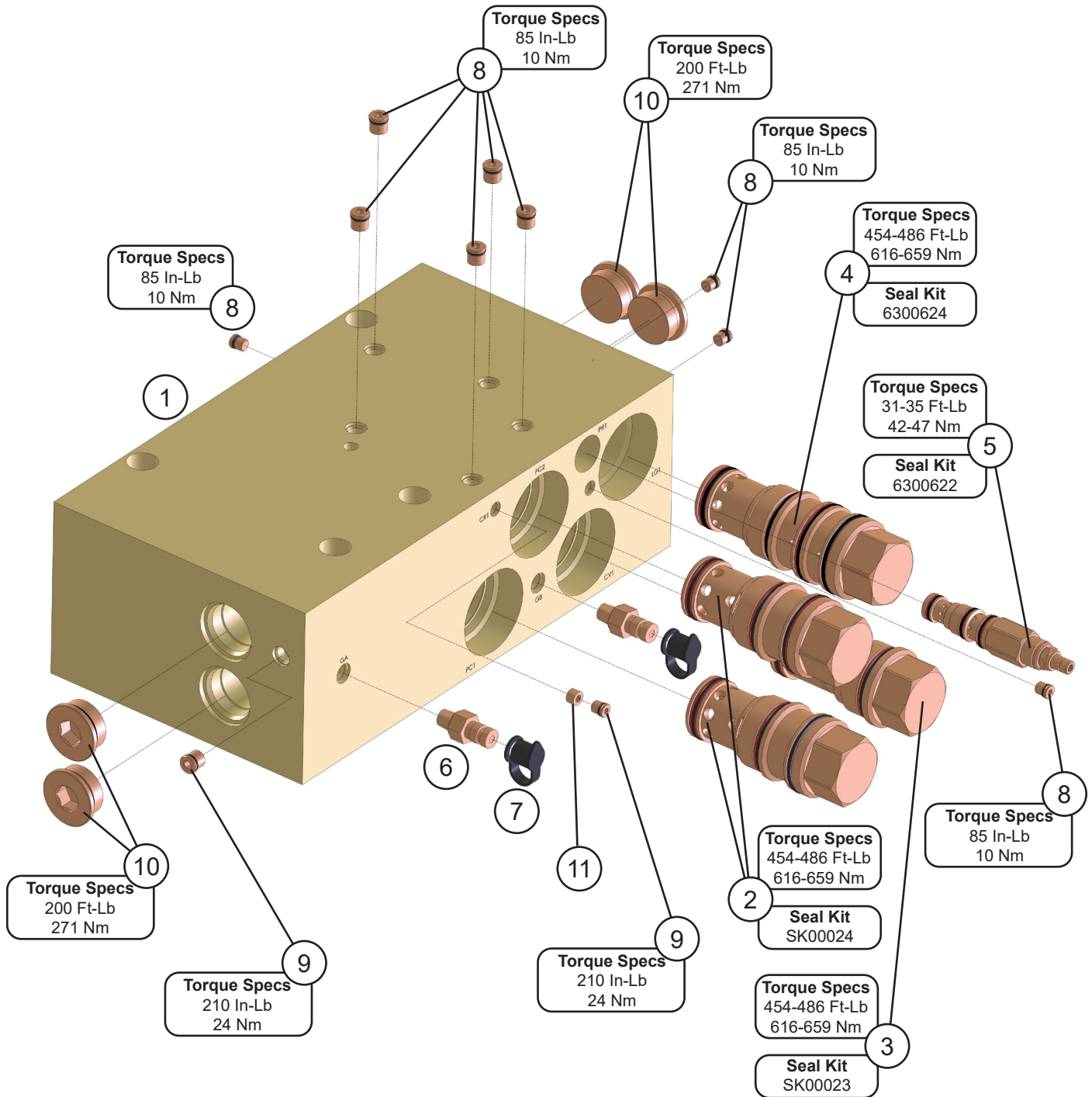

REGEN BLOCK SUB-ASSEMBLY - 6360021

ITEM	QTY	PART NUMBER	DESCRIPTION	
1	1	6360021	Manifold Block	Seal Kit SK00129
2	2	6300061	Pilot to Close Check Valve	Seal Kit SK00024
3	1	6380011	Check Valve	Seal Kit SK00023
4	1	6300623	Logic Element	Seal Kit 6300624
5	1	6300625	Pressure Reducing Valve	Seal Kit 6300622
6	2	6300088	Diagnostic Nipple	
7	2	6310001	Diagnostic Nipple Dust Cap	
8	9	6300075	Plug Socket Head 02MB	
9	4	6300076	Plug Socket Head 04MB	
10	4	6300078	Plug Socket Head 16MB	
11	1	6300903	Plug Pipe Orifice 01MP 1/16-27 NPT	

ASSEMBLY SLEWING RING LUBRICATION

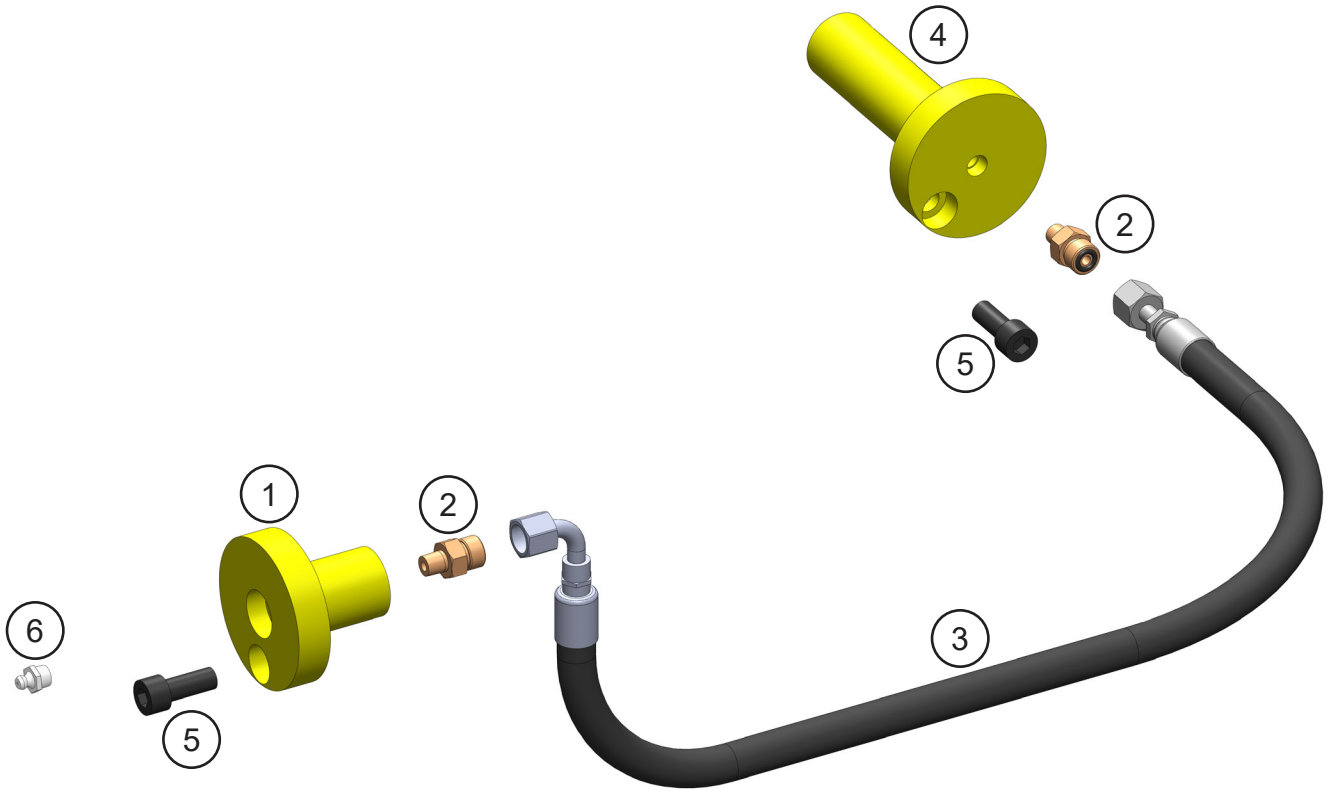

ASSEMBLY SLEWING RING LUBRICATION

ITEM	QTY	PART NUMBER	DESCRIPTION
1	1	5512411	Mach Grease Bulkhead Adapter
2	2	6300731	Adaptor 02MP-04MO
3	1	5517830	Hose
4	1	5512419	Mach Slewing Ring Grease Adapter
5	2	F0610025	Socket Head Capscrew M10 x 1.50 x 25
6	1	6200002	Grease Fitting

BOLT TORQUE SPECIFICATIONS

Reference the product Thread Treatment Diagram on page 41 to determine whether to use wet or dry torque values for specific bolts.

Reference Procedures on page 42 for threadlocker or anti-seize application and bolt and bolt hole cleaning.

Prior to torquing, clean all bolt holes, bolts and nuts to remove dirt, grease and oil, and identify bolt type.

Never re-torque bolts that use Loctite. If a bolt becomes loose or damaged after the initial use when Loctite was applied and the bolt was torqued, the bolt must be replaced.

Never break tightened bolts loose with a torque wrench. Doing so may break the torque wrench or take it out of calibration.

Torque wrenches should be calibrated on an annual basis.

When using a torque multiplier with a torque wrench, incorrect settings will be multiplied by the ratio of the torque wrench.

Never use an impact driver on a torque multiplier.

THREAD TREATMENT DIAGRAM

Mobile Shears

Use this diagram to determine what thread treatment, if any, is required for each fastener.

For thread treatment application procedures, see page 42. For prescribed torque values, see page 44.

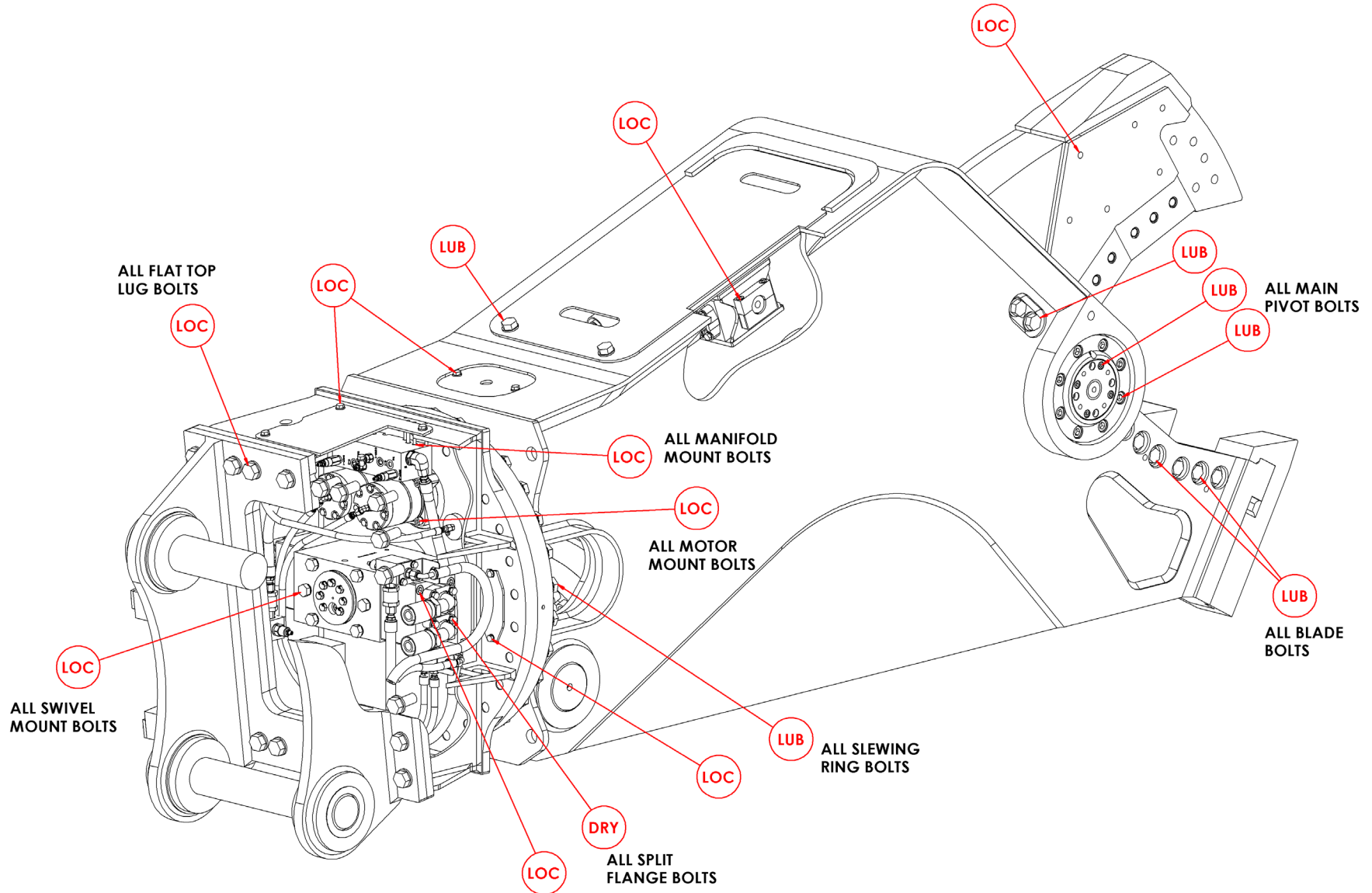

PROCEDURES

Reference the product Thread Treatment Diagram on page 41 to determine which of the following procedures is required.

Cleaning

To ensure proper performance of thread treatment and accurate torque values, clean and degrease **all internal and external threads** prior to application of threadlocker, anti-seize or primer and before installation of hardware.

- Ensure both internal and external threads are free of dirt or debris.
- Use brake cleaner or similar cleaning solvent on all threads to remove any grease or oil.
- Allow threads to dry.

NOTICE

Failure to properly clean threads will cause threadlocker, primer, and/or anti-seize to not properly cure!

LOC

Threadlocker

For bolted connections requiring threadlocker, use **Loctite 263** or equivalent applied using the following procedure:

- Clean and degrease all threads.
- For thru holes or nuts, apply threadlocker to bolt threads.
- For blind holes, apply stripe of threadlocker along the length of the hole (applying to the bolt can cause escaping air to remove threadlocker as the bolt is inserted).
- Torque bolt to specified **Wet Torque Value**, see page 44.

For threaded hydraulic fitting connections, use **Loctite 5452** or equivalent thread sealant in conjunction with **Loctite 7471** primer using the following procedure:

- Clean and degrease all threads.
- Apply Loctite 7471 primer to both external and internal threads and allow to dry.
- Apply threadlocker to 360 degrees of the threads on the male fitting, ensuring adequate coverage.
- Assemble fitting per directions in operator's manual.
- For O-ring boss and flat face O-ring connections, torque fittings to values specified on page 45.

Threadlocker

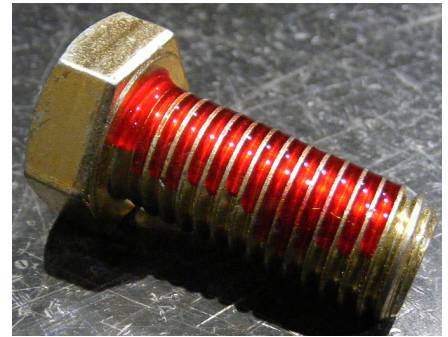

Blind Hole

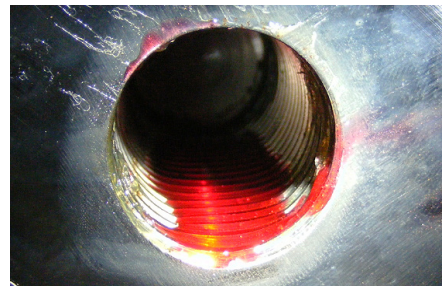

Hydraulic Fitting



PROCEDURES

LUB

Anti-Seize

For bolted connections requiring anti-seize lubrication, use **Loctite LB8008** or equivalent using the following procedure:

- Clean and degrease all threads.
- Apply thin coat of anti-seize to internal and external threads and under bolt head and/or nut, ensuring complete coverage.
- Torque bolt to specified **Wet Torque Value**, see page 44.

Anti-Seize









DRY

No Thread Treatment

- Clean and degrease all threads.
- Torque bolt to specified **Dry Torque Value**, see page 44.

BOLT TORQUE SPECIFICATIONS

Dry Torque Values					
		Hex/Socket Head		Flat Head	
		 			
Fastener Grade	Size x Pitch	Nm	Ft-lb	Nm	Ft-lb
CL 10.9	M8 x 1.25	35	26	27	20
	M10 x 1.50	71	53	58	42
	M12 x 1.75	124	92	101	73
	M14 x 1.50	200	148	163	118
	M14 x 2.00	200	148	163	118
	M16 x 2.00	311	230	254	184
	M20 x 1.50	610	450	498	360
	M20 x 2.50	608	449	497	359
	M24 x 3.00	1054	778	861	622
	M27 x 3.00	1543	1138	1260	910
	M30 x 3.50	2095	1545	1712	1236
	M36 x 4.00	3659	2699	2991	2159
8	1/4-20	14	11	11	8
	5/16-18	32	24	26	19
	3/8-16	59	44	48	35
	7/16-14	94	70	77	56
	1/2-13	143	106	116	84
	1/2-20	162	120	133	96
	5/8-11	287	212	234	169
	3/4-10	509	376	415	300
	7/8-9	821	606	670	484
	1.00-8	1232	909	1007	727
	1.00-14	1383	1020	1130	816
	1.25-7	2463	1817	2013	1453
8/L9	1.50-6	4287	3162	3504	2529

Wet Torque Values					
		Hex/Socket Head		Flat Head	
		 			
Fastener Grade	Size x Pitch	Nm	Ft-lb	Nm	Ft-lb
CL 10.9	M8 x 1.25	29	22	23	17
	M10 x 1.50	61	45	49	36
	M12 x 1.75	105	78	85	62
	M14 x 1.50	150	111	121	88
	M14 x 2.00	170	126	138	100
	M16 x 2.00	265	196	216	156
	M20 x 1.50	456	337	372	269
	M20 x 2.50	517	382	422	305
	M24 x 3.00	894	660	731	528
	M27 x 3.00	1312	968	1072	774
	M30 x 3.50	1779	1312	1453	1049
	M36 x 4.00	3110	2294	2542	1835
8	1/4-20	13	10	11	8
	5/16-18	27	20	22	16
	3/8-16	50	37	40	29
	7/16-14	80	59	65	47
	1/2-13	122	90	99	72
	1/2-20	138	102	112	81
	5/8-11	244	180	199	144
	3/4-10	433	320	354	256
	7/8-9	698	515	570	412
	1.00-8	1046	772	854	617
	1.00-14	1175	867	960	693
	1.25-7	2095	1545	1712	1236
8/L9	1.50-6	3644	2688	2979	2150

O-RING BOSS & FLAT FACE O-RING TORQUE SPECIFICATIONS

O-Ring Boss Torque Values		
Size Dash	Nm	Ft-lb
-4	22	16
-5	27	20
-6	36	26
-8	83	60
-10	110	80
-12	187	135
-14	249	180
-16	304	220
-20	387	280
-24	498	360

Flat Face O-Ring Torque Values		
Size Dash	Nm	Ft-lb
-4	18	13
-6	30	22
-8	60	44
-10	85	62
-12	121	88
-14	121	88
-16	160	116
-20	213	154
-24	274	198

BOLT DRIVE SPECIFICATIONS

Thread Size x Pitch	Hex Head	Socket Head	Flat Head
			
Wrench/Drive Size			
M8 x 1.25	13mm	6mm	5mm
M10 x 1.50	17mm	8mm	6mm
M12 x 1.75	19mm	10mm	8mm
M14 x 1.50	22mm	12mm	10mm
M14 x 2.00	22mm	12mm	10mm
M16 x 2.00	24mm	14mm	10mm
M20 x 1.50	30mm	17mm	12mm
M20 x 2.50	30mm	17mm	12mm
M24 x 3.00	36mm	19mm	14mm
M27 x 3.00	41mm	19mm	-
M30 x 3.50	46mm	22mm	-
M36 x 4.00	55mm	27mm	-
1/4-20	7/16"	3/16"	5/32"
5/16-18	1/2"	1/4"	3/16"
3/8-16	9/16"	5/16"	7/32"
7/16-14	5/8"	3/8"	1/4"
1/2-13	3/4"	3/8"	5/16"
1/2-20	3/4"	3/8"	5/16"
5/8-11	15/16"	1/2"	3/8"
3/4-10	1-1/8"	5/8"	1/2"
7/8-9	1-5/16"	3/4"	9/16"
1.00-8	1-1/2"	3/4"	5/8"
1.00-14	1-1/2"	3/4"	5/8"
1.25-7	1-7/8"	7/8"	7/8"
1.50-6	2-1/4"	1"	1"

WARRANTY

Claim Procedure

Notify the Genesis Service Department of the potential warranty claim prior to making the repair. Digital pictures are very helpful for diagnosing problems and recommending repairs.

Contact the Genesis Service Department before making alterations, changes or repairs to any component that is going to be considered for warranty. Not doing so will void all Genesis warranty consideration.

The Genesis Service Department will issue an authorization number to track the repair costs, outgoing parts, and/or defective parts returning to the factory.

Replacement parts must be ordered using a purchase order number. Shipping is standard ground. Overnight shipping is available by request, and Genesis will not cover the shipping charge.

When the repair is complete, submit an invoice to the Genesis Service Department within 30 days. Include itemized internal labor reporting, parts lists and invoices for outside contractors. Reference the authorization number on all invoices.

When returning parts for warranty consideration, include a copy of any related Genesis paperwork along with any other necessary documentation to ensure proper processing and credit. The Genesis Service Department will provide the necessary forms.

Your account will be credited when the warranty claim is accepted.

Blade Warranty

Standard warranty on blades will only be considered on the first edge, and wear on the edge must be 1/8" radius or less. Genesis does not warranty cutting blades that are cracked or broken from top to bottom (perpendicular to the long edge of the blade). Genesis also does not cover fasteners, the labor to replace wear components or collateral damage, such as blade seats, from broken blades, the piercing blade tang or adjustment plates.

Please direct any questions to the Genesis Service Department: 715-395-5252

PARTS ORDER POLICY AND PROCEDURE

Parts Orders Should Include

- Purchase order number
- Model and serial number of attachment
- Part number and quantity needed
- Shipping and billing address
- Method of shipment or required delivery date

Placing Orders

Orders may be placed by phone or e-mail. To e-mail an order, use the form on the following page or your purchase order form. Contact information is located at the front of this manual.

Part Numbers

Part numbers are listed in a separate Parts Manual or, if included, the Parts section of this manual. Contact the Genesis Parts Department with questions regarding part numbers, availability and pricing.

Shipping

All orders will be shipped best way surface unless an alternate shipping method is requested. Shipping charges are not included in the purchase price of parts.

Invoices

All invoices are due upon receipt. Any accounts with invoices open beyond 60 days are subject to review and may be placed on C.O.D. status without further notice.

Returns

Many unused Genesis parts may be returned with proper documentation. Return shipping is the responsibility of the purchaser. Credit will be issued upon return, less a 25% restocking fee. Documentation is required for credit of returned parts. Contact the Genesis Service Department at 715-395-5252 for an RGA (Return Goods Authorization) number and form. An RGA must accompany every return. Items shipped without an RGA may be returned to sender.

Warranty Returns

All parts returned to Genesis for warranty consideration must be returned with a completed RGA (Return Goods Authorization) provided by the Genesis Service Department. The form needs to be completed in its entirety, including any additional information requested by the Service Department. Return shipping is the responsibility of the sender and will be credited upon claim approval. A determination to accept or deny the claim will be made based upon the information available to Genesis. Warranty on purchased parts other than wear components is 6 months. Genesis does not cover labor costs to replace purchased parts replaced under warranty. There is no warranty period on wear parts or components.

PARTS ORDER FORM

Customer: _____ Date: _____

Phone: _____ Contact: _____

Shipping Address: _____ E-mail: _____

_____ Billing Address: _____

Purchase Order: _____ Shipping Method: _____

Model: _____ Serial Number: _____

Quantity	Part Number	Description	Price

E-mail to the Genesis Parts Department: genesisparts@genesisattachments.com
For assistance, call 715-395-5252

INDEX

- 1-1/4" Split Flange Kit 33
- 1105878 Wtmg Sub Head Cover 21
- 1105883 Plt Bolt Cover 21
- 1106478 Shim Set, Auto Guide 15
- 1106542 Mach Tie Rod Nut 7
- 1106546 Wldt Front Cyl Pin 17
- 1106571 Mach Pin Keeper Rear 17
- 1106592 Mach Bearing Upper Cylinder Connection 17
- 1109142 Mach Rear Cyl Pin 17
- 1109143 Plt Rear Cover 19
- 1109201 Wldt Pivot Valve Tray 33
- 1109209 Lower Regen Tray Bar 33
- 1109210 Upper Regen Tray Bar 33
- 1109586 Mach Bearing RH 7
- 1109587 Mach Bearing LH 9
- 1109588 Mach End Cap 7, 9
- 1109590 Mach Tie Rod Nut 9
- 1109592 Mach Thrust Washer 7, 9
- 1109593 Mach Tie Rod 7
- 1109594 Shim Set Thrust Washer 7, 9
- 1109595 Mach Main Shaft 9
- 1109599 Mach Tusk 11
- 1109611 Mach Blade Tip Left 13
- 1109612 Mach Blade Tip Right 13
- 1109618 Mach Upper Side Wear Plt 13
- 1109621 Mach Adjust Plate Primary 11
- 1109623 Mach Adjust Plate Secondary 11
- 1109632 Wldt Cover 19
- 1109636 Hose 33
- 1109637 Hose 33
- 1109638 Hose 33
- 1109639 Hose 33
- 3101235 Pinion Gear, Tapered Shaft 27
- 3500350 Mach Pin Keeper (Clevis) 17
- 3501835 Mach Spacer 27
- 3502808 Blade Shim Set 11
- 3503690 Mach Blade 11, 13
- 5500752 Plt Strap 21
- 5512411 Mach Grease Bulkhead Adapter 39
- 5512419 Mach Slewing Ring Grease Adapter 39
- 5517828 Hose 29
- 5517829 Hose 29
- 5517830 Hose 39
- 5517832 Hose 29
- 6200002 Grease Fitting 7, 9, 17, 21, 39
- 6300018 Adapter 06MB-06MO 29
- 6300061 Pilot to Close Check Valve 37
- 6300075 Plug Socket Head 02MB 37
- 6300076 Plug Socket Head 04MB 37
- 6300078 Plug Socket Head 16MB 37
- 6300088 Diagnostic Nipple 37
- 6300361 Valve Flow Control 31
- 6300364 Filter 31
- 6300429 Bearing Slewing 27
- 6300623 Logic Element 37
- 6300625 Pressure Reducing Valve 37
- 6300731 Adapter 02MP-04MO 39
- 6300768 Adapter 04MB-04MO-90 29
- 6300903 Plug Pipe Orifice 01MP 1/16-27NPT 37
- 6302658 Valve Line Body 31
- 6302661 Case Drain Manifold 29
- 6310001 Diagnostic Nipple Dust Cap 37
- 6310050 Adapter 08MB-08MO 31
- 6310082 Adapter 12MB-08MO-90 29
- 6310183 Adapter 08MB-08MB 31
- 6360021 Manifold Block 37
- 6380011 Check Valve 37
- 6380090 Motor 27
- 50210450 Hex Head Capscrew 1 - 8 x 4.50 15
- Assembly Access Covers 5, 19
- Assembly Auto Guides 5, 14, 15
- Assembly Cylinder 5
- Assembly Cylinder B13.0 R8.5 S26.00 33
- Assembly Cylinder Pins 5, 16, 17
- Assembly Lower Blades 5, 10, 11
- Assembly Lugs for Flat-top Head 5, 24, 25
- Assembly Open and Close Circuit 5, 32, 33
- Assembly Pivot Group - Left Side 5, 8, 9
- Assembly Pivot Group - Right Side 5, 6, 7
- Assembly Rotation 5, 26, 27, 29
- Assembly Rotation Circuit 5, 28, 29
- Assembly Slewing Ring Lubrication 5, 29, 38, 39
- Assembly Swivel Manifold 5, 33, 35
- Assembly Swivel Manifold - 6350063 34, 35
- Assembly Upper Blades & Wear Plate 5, 12, 13
- Assembly Upper Head - Second-Member 20, 21
- Assembly Upper Head Second-Member/Third-Member 5
- Assembly Upper Head - Third-Member 22, 23
- Bar Strap 25
- Bearings and/or Spacer Sleeves 23
- Bolt Drive Specifications 46
- Bolt Torque Specifications 40, 44
- Bracket Fasteners 25
- Contact Information 2, 52
- Cylinder Link Pin 23
- F0110030 Hex Head Capscrew M10 x 1.50 x 30 21
- F0112020 Hex Head Capscrew M12 x 1.75 x 20 19
- F0112030 Hex Head Capscrew M12 x 1.75 x 30 21
- F0112050 Hex Head Capscrew M12 x 1.75 x 50 33
- F0116060 Hex Head Capscrew M16 x 2.00 x 60 33
- F0120180 Hex Head Capscrew M20 x 2.5 x 180 13
- F0120260 Hex Head Capscrew M20 x 2.5 x 260 35
- F0124040 Hex Head Capscrew M24 x 3 x 40 19
- F0124130 Hex Head Capscrew M24 x 3 x 130 11
- F0124175 Hex Head Capscrew M24 x 3 x 175 13
- F0127070 Hex Head Capscrew M27 11
- F0127120 Hex Head Capscrew M27 x 3 x 120 27
- F0210500 Hex Head Capscrew 1 - 8 x 5 15
- F0412030 Flat Head Capscrew M12 x 1.75 x 30 7, 9

INDEX

F0610025 Socket Head Capscrew M10 x 1.50 x 25	39	Strap	23
F0612025 Socket Head Capscrew M12 x 1.75 x 25	7, 9	Sub-Assembly Line Mount Manifold - 6302659	5, 29, 30, 31
F0612055 Socket Head Capscrew M12 x 1.75 x 55	33	Sub-Assembly Regen Block	5
F0612120 Socket Head Capscrew M12 x 1.75 x 120	33	Table of Contents	3
F0616130 Socket Head Capscrew M16 x 2 x 130	33	Thread Treatment Diagram	41
F0620070 Socket Head Capscrew M20 x 2.50 x 70	7, 9	Torque Arm Kit	35
F0620100 Socket Head Capscrew M20 x 2.50 x 100	17	Upper Head	23
F0620180 Socket Head Capscrew M20 x 2.50 x 180	17	Valve Regen	33
F0627155 Socket Head Capscrew M20	13	Warranty	47
F1020250 Nylock Hex Nut M20 x 2.50	17	Washer	25
F1201021 Flat Washer M10	21	Wldt Link Pin	25
F1201224 Flat Washer M12	19, 21	Wldt Pin	21
F1202444 Flat Washer M24	11, 13, 19	Wldt Stick Pin	25
F1300100 Flat Washer Narrow 1"	15	Wtmg Lugs	25
F1401200 Lock Washer M12	21, 33	Wtmg Lug Upper Head	4, 21
F1401628 Lock Washer M16	33	Wtmg Stick	5
F1900075 Washer M20	13	Wtmg Sub Head	21
F1900075 Wedge Lock Washer ¾	35	Wtmg Upper	5
F2802700 Hytorc Reaction Washer M27	11		
F2802700 Hytorc Washer	27		
Flat Washer	23		
General Arrangement	4, 5		
H0262125 Split Flange Half 1.25 Code 62	33		
H0262150 Split Flange Half 1.50 Code 62	33		
Hex Head Capscrew	23, 25		
Inspection/Access Cover	23		
Lock Washer	23		
Mach Auto Guide - Blade Side	15		
Mach Auto Guide - Guide Side	15		
Mach Bearing	21		
Mach Boom Bearing	21		
Mach Pin Keeper	25		
Mach Port Block	33		
Mach Spacer Sleeve	21, 25		
O-Ring	33		
O-Ring Boss & Flat Face O-Ring Torque Specifications	45		
Parts Order Form	49		
Parts Order Policy and Procedure	48		
Pin Keeper	23		
Port Block Assembly	23		
Procedures	42, 43		
Regen Block Sub-Assembly - 6360021	36, 37		
S0190222 O-Ring	33		
S0190225 O-Ring	33		
S0190238 O-Ring	7, 9		
Seal Kit 6300622	36, 37		
Seal Kit 6300624	36, 37		
Seal Kit 6300634	30, 31		
Seal Kit SK00023	36, 37		
Seal Kit SK00024	36, 37		
Seal Kit SK00129	37		
Spacer Sleeves, Cylinder Link Pin	23		
Stick Pin	23		
Stick Pin Decal	25		



GENESIS®

The Promise of Performance.

CONTACT INFORMATION

Genesis Attachments

1000 Genesis Drive
Superior, WI 54880 USA

Toll Free: 888-SHEAR-IT
(888-743-2748)

Phone: 715.395.5252

E-mail:
info@genesisattachments.com

Europe/Africa/Middle East Genesis GmbH

Teramostrasse 23
87700 Memmingen, Germany

Phone: +49 83 31 9 25 98 0
Fax: +49 83 31 9 25 98 80
genesis-europe.com

E-mail:
info@genesis-europe.com

Asia Pacific Representative Office

24 Upper Serangoon View #12-28
Singapore 534205

Phone: +65 9673 9730

E-mail:
tchoo@genesisattachments.com

Central America & Colombia

Cra 13A #89-38 / Ofi 613
Bogota, Colombia

Phone: +57 1 610 8160 / 795 8747

E-mail:
contact@themsagroup.com

View and download all manuals: genesisattachments.com/manuals
Patents: genesisattachments.com/products/patents