



Handling Grapple (GHG) Models GHG 4 - GHG 50

SAFETY & OPERATOR'S MANUAL



CONTACT INFORMATION

Genesis Attachments

1000 Genesis Drive
Superior, WI 54880 USA

Toll Free: 888-SHEAR-IT
(888-743-2748)

Phone: 715.395.5252

E-mail:
info@genesisattachments.com

Europe/Africa/Middle East Genesis GmbH

Teramostrasse 23
87700 Memmingen, Germany

Phone: +49 83 31 9 25 98 0
Fax: +49 83 31 9 25 98 80
genesis-europe.com

E-mail:
info@genesis-europe.com

Asia Pacific Representative Office

24 Upper Serangoon View #12-28
Singapore 534205

Phone: +65 9673 9730

E-mail:
tchoo@genesisattachments.com

Central America & Colombia

Cra 13A #89-38 / Ofi 613
Bogota, Colombia

Phone: +57 1 610 8160 / 795 8747

E-mail:
contact@themsagroup.com

View and download all manuals: genesisattachments.com/manuals
Patents: genesisattachments.com/products/patents

PREFACE

To ensure years of safe, dependable service, only trained and authorized persons should operate and service your Genesis attachment. It is the responsibility of the product's owner to ensure the operator is trained in the safe operation of the product and has available this manual for review. It is the responsibility of the operator and maintenance personnel to read, fully understand and follow all operational and safety-related instructions in this manual. The attachment should not be operated until you have read and fully understand these instructions. Always use good safety practices to protect yourself and those around you.

Important

This operator's manual must accompany the attachment at all times and be readily available to the operator.

Manual Replacement

Should this manual become damaged or lost or if additional copies are required, immediately contact any authorized Genesis dealer or the Genesis Service Department at 888-743-2748 or 715-395-5252 for a replacement.

Registration Form

The Warranty Registration Form must be filled out by the dealer or customer and returned to Genesis indicating the date the attachment went into service.

Possible Variations

Genesis cannot anticipate every possible circumstance that might involve a potential hazard as the owner's requirements and equipment may vary. Therefore, the warnings in this publication and on the product may not be all-inclusive, and you must satisfy yourself that the procedure, application, work method or operating technique is safe for you and others before operating.

Public Notice

Genesis reserves the right to make changes and improvements to its products and technical literature at any time without public notice or obligation. Genesis also reserves the right to discontinue manufacturing any product at its discretion at any time.

Warranty

All work or repairs to be considered for warranty reimbursement must be pre-authorized by the Genesis Service Department. Any alterations, modifications or repairs performed before authorization by the Genesis Service Department will render all warranty reimbursement consideration null and void without exception. See page 53 for Warranty Claim Procedures.

Improper operation or improperly performed maintenance may render any warranty null and void.

TABLE OF CONTENTS

CONTACT INFORMATION	2
PREFACE	3
Important.....	3
Manual Replacement.....	3
Registration Form.....	3
Possible Variations.....	3
Public Notice.....	3
Warranty.....	3
SAFETY STATEMENTS	7
OPERATIONAL SAFETY	8
Read Manual Before Operating or Maintaining the Attachment.....	8
Personal Protection.....	8
Know Your Equipment.....	8
Before Operating.....	8
Check the Equipment.....	9
Stability.....	9
Know the Work Area.....	10
Starting Procedure.....	10
Place the Load Safely.....	10
Safely Operate Equipment.....	11
Transporting the Attachment.....	12
Equipment Condition.....	12
Working Overhead.....	12
Power Lines.....	12
Use Care with Hydraulic Fluid Pressure.....	13
Prioritized Oil Flow.....	14
Emergency Situations.....	14
Unsafe Conditions.....	14
Crystalline Silica Dust.....	14
Process Material Safely.....	15
Lift the Load Safely.....	15
Place the Load Safely.....	15
SERIAL NUMBER LOCATION	16
MAINTENANCE SAFETY	17
Pinch Points & Crush Points.....	17
Performing Maintenance.....	17
MAINTENANCE	20
Daily Inspection and Maintenance.....	20
Arm Maintenance.....	20
Frame Maintenance.....	20
Frame Crack Repair.....	20
SLEWING RING MAINTENANCE	21

TABLE OF CONTENTS

ROTARY JOINT MAINTENANCE	22
Hydraulic Rotary Joint Assembly.....	22
Seal Leakage.....	22
Testing the Rotary Joint Seals for Internal Leakage.....	22
Rotary Joint Seal Replacement.....	23
LUBRICATION POINTS	25
GENERAL WELDING GUIDELINES	26
Welding Ground Clamp.....	26
Welding Rules.....	26
HARD-SURFACING	27
HYDRAULIC FLOW AND PRESSURE	28
Flow and Pressure Specifications.....	28
HYDRAULIC INSTALLATION	29
Hydraulic Lines.....	29
Shut-Off Valves.....	29
Port Connection Diagram.....	30
HYDRAULIC CIRCUITS	31
Cylinder Hydraulic Circuit.....	31
Single Motor Hydraulic Circuit.....	32
Dual Motor Hydraulic Circuit.....	32
GRAPPLE INSTALLATION	33
Mounting to the Excavator.....	34
Removal from the Excavator.....	34
Grapple Storage.....	34
OPERATING TECHNIQUES AND PRECAUTIONS	35
TROUBLE-SHOOTING GUIDE	36
Determine the Type of Problem.....	36
Determine the Cause of the Problem.....	36
Guide for Power Loss.....	36
Measuring Operating Pressures.....	36
Relief Valve Checking and Setting.....	36
Counterbalance Valve Location.....	38
Low Power.....	39
Slow Cylinder Speed.....	40
Checking Hydraulic Flow at Rated Pressure.....	40
Slow Cylinder Speed.....	42
Jaw Drift.....	42
Slow Rotation Speed.....	43
Measuring Rotation Pressures.....	44
Checking Rotation Pressure.....	44
Rotation Speed Adjustment.....	45
Torque Charts.....	46
PINION GEAR INSTALLATION	49
CYLINDER TORQUE SPECIFICATIONS	50
Rod Nut and Piston Torques.....	50

TABLE OF CONTENTS

CONVERT FROM DUAL MOTOR TO SINGLE MOTOR	51
Models GHG 20 - GHG 40.....	51
COMPONENT KEYWORDS	52
WARRANTY	53
Claim Procedure.....	53
PARTS ORDER POLICY AND PROCEDURE	54
Parts Orders Should Include.....	54
Placing Orders.....	54
Part Numbers.....	54
Shipping.....	54
Invoices.....	54
Returns.....	54
Warranty Returns.....	54
PARTS ORDER FORM	55
CONTACT INFORMATION	56

SAFETY STATEMENTS



This symbol by itself or used with a safety signal word throughout this manual is used to call attention to instructions involving your personal safety or the safety of others. Failure to follow these instructions can result in injury or death.



This statement is used where serious injury or death will result if the instructions are not followed properly.



This statement is used where serious injury or death could result if the instructions are not followed properly.



This statement is used where minor or moderate injury could result if the instructions are not followed properly.

NOTICE

This statement is used where property damage could result if the instructions are not followed properly.

OPERATIONAL SAFETY

Read Manual Before Operating or Maintaining the Attachment



Read this manual before attempting to operate the attachment. This operator's manual should be regarded as part of the attachment. For proper installation, operation and maintenance of the attachment, operators and maintenance personnel must read this manual.



WARNING

Serious injury or death could result if appropriate protective clothing and safety devices are not used.

Personal Protection

Use protective clothing and safety devices appropriate for the working conditions. These may include but are not limited to:

- ✓ Hard hat
- ✓ Safety glasses, goggles or face shield
- ✓ Hearing protection
- ✓ Safety shoes
- ✓ Heavy gloves
- ✓ Reflective clothing
- ✓ Respirator or filter mask



Safety matters

Know Your Equipment

Know your attachment's capabilities, dimensions and functions before operating. Inspect your attachment before operating and never operate an attachment that is not in proper working order. Remove and replace any damaged or worn parts.

Before Operating

- ✓ Warn all others in the area that you are about to start operation.
- ✓ Perform the Check the Equipment steps outlined in this manual.
- ✓ Check underneath and around the machine. Make sure all personnel and equipment are clear from the area of operation and equipment movement. Check clearances in all directions, including overhead.
- ✓ Be properly seated in the operator's seat.
- ✓ Do not attempt to operate until you have read and fully understand this manual and the OEM manual for the carrier.

OPERATIONAL SAFETY

Check the Equipment

Before use, check the equipment to ensure it is in good operating condition.

Check the following:

- ✓ Grease fittings. Pump grease at all fitting locations, see page 25.
- ✓ Hydraulic fluid level. Add hydraulic fluid as required.
- ✓ Hydraulic hoses and hose connections for wear or leaks. Repair or replace any damaged hoses or connections.
- ✓ All control levers for proper operation.
- ✓ Rotation bearing. Visually check for loose or damaged bolts. If repair is required, refer to qualified personnel.
- ✓ Check cylinders for dents (barrel) or dings (rod).
- ✓ Do not operate without inspection/access covers in place.



**GOOD
CONDITION**



WARNING

Serious injury or death could result if carrier stability and compatibility warnings and instructions are not followed.

Stability

Your Genesis attachment is sized for carrier stability. However, improper operation, faulty maintenance or unauthorized modifications may cause instability. The excavator weight ranges below are intended as a guideline only. Other factors, such as stick length, counterweights and under-carriage must be taken into consideration.

Mounting an attachment that is too heavy for the excavator can be dangerous and damage the machine. Verify excavator stability with the attachment before transport or operation. Mounting an attachment that is too small for the excavator can damage the attachment and void the warranty. Contact Genesis for specific detailed information.

Model	Recommended Excavator Class 3 rd Member Mounting	
	US Pounds	Metric Ton
GHG 4	5,500 - 9,000	2 - 4
GHG 6	9,000 - 13,000	4 - 6
GHG 9	11,000 - 20,000	5 - 9
GHG 14	15,000 - 31,000	7 - 14
GHG 16	22,000 - 35,000	10 - 16
GHG 20	31,000 - 44,000	14 - 20
GHG 25	35,000 - 57,000	16 - 26
GHG 30	40,000 - 66,000	18 - 30
GHG 40	55,000 - 88,000	25 - 40
GHG 50	77,000 - 110,000	35 - 50

OPERATIONAL SAFETY

Know the Work Area

Check clearances in the work area. Keep all bystanders at a safe distance. Do not work under obstacles. Always check your location for overhead and buried power lines or other utilities before operation.

Check ground conditions. Avoid unstable or slippery areas. Position the carrier on firm level ground. If level ground is not possible, position the carrier to use the attachment to the front or back of the carrier. Avoid working over the side of the carrier.

For greater stability, knuckle the attachment to bring the load closer to the center of rotation (center of gravity) while lifting. Use extra caution during reaching to avoid tipping.

To reduce the risk of tipping and slipping, never park on a grade exceeding 10% (one-foot rise over the span of a ten-foot run).

Starting Procedure

Before operating, walk completely around the equipment to make certain no one is under it, on it or close to it. Keep all bystanders at least 75 feet away from the area of operation and equipment movement. Let all other workers and bystanders know you are preparing to start. DO NOT operate until everyone is clear.

Always be properly seated in the operator's seat before operating any carrier controls.

To start:

- ✓ Make sure all controls are in the center (neutral) position.
- ✓ Be properly seated.
- ✓ Slowly operate all functions to check for proper operation and to bleed air from the hydraulic system.

To shut down:

- ✓ Return your Genesis attachment to a rest position on the ground.
- ✓ Shut off the carrier engine.
- ✓ Work controls in all directions to relieve hydraulic pressure, per excavator manufacturer's instructions.



WARNING

Serious injury or death could result if warnings or instructions regarding safe operation are not followed properly.

Place the Load Safely

Do not move the attachment, or anything held in the jaws, over people, equipment or buildings. Do not throw or drop the contents. Operate the controls smoothly and gradually.

OPERATIONAL SAFETY

Safely Operate Equipment

Do not operate equipment until you are trained by a qualified operator in its use and capabilities.

See your carrier's manual for these instructions.

- ✓ Operate only from the operator's seat. Check the seat belt daily and replace if frayed or damaged.
- ✓ Do not operate without inspection (access) covers in place.
- ✓ Do not operate without an impact resistant shield between the grapple and the operator.
- ✓ Operate with extreme caution near walls or columns that may collapse and near concrete debris that may fall.
- ✓ Do not operate this or any other equipment under the influence of drugs or alcohol. If you are taking prescription medication or over-the-counter drugs ask your medical provider whether you can safely operate equipment.
- ✓ Never leave equipment unattended with the engine running or with the attachment in a raised position. Apply the brakes before exiting the equipment.
- ✓ Do not exceed the lifting capacity of your carrier.
- ✓ Avoid conditions that can lead to tipping. The carrier can tip when operated on hills, ridges, banks and slopes. Avoid operating across a slope which could cause the carrier to overturn.
- ✓ Reduce speed when driving over rough terrain, on a slope, or when turning to avoid overturning the carrier.
- ✓ Never use the attachment as a work platform or personnel carrier.
- ✓ Keep all step plates, grab bars, pedals and controls free of dirt, grease, debris and oil.
- ✓ Never allow anyone to be around the equipment when it is operating.
- ✓ Do not operate poorly maintained or otherwise faulty equipment. Inform the proper authority and DO NOT resume operation until the problem has been fixed.
- ✓ Do not alter or remove any safety features.
- ✓ Know your work site safety rules as well as traffic rules and flow. When in doubt on any safety issue, contact your supervisor or safety coordinator for an explanation.
- ✓ A heavy load can cause equipment instability. Use extreme care during travel. Slow down on turns and watch out for bumps. The equipment may need additional counterweights to counterbalance the weight of the attachment.



OPERATIONAL SAFETY

Transporting the Attachment

- ✓ Travel only with the attachment in a safe transport position to prevent uncontrolled movement. Drive slowly over rough ground and on slopes.
- ✓ When driving on public roads use safety lights, reflectors, Slow Moving Vehicle signs, etc., to prevent accidents. Check local government regulations that may affect you.
- ✓ Do not drive close to ditches, excavations, etc., as cave-in could result.
- ✓ Do not smoke when refueling the prime mover. Allow room in the fuel tank for expansion. Wipe up any spilled fuel. Secure cap tightly when done.

Equipment Condition

Never operate poorly maintained equipment. When maintenance is required, repair or replace parts immediately.



WARNING

Serious injury or death could result if warnings or instructions regarding working overhead are not followed properly.

Working Overhead

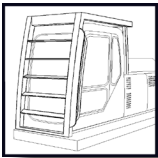

Avoid handling material overhead whenever possible. Safety glass and wire mesh cab guarding must be installed to protect the operator from flying debris that may be created during handling. Falling Object Protection Structures, or FOPS, are necessary for any application where material is to be handled overhead.



DANGER

Serious injury or death will result if warnings or instructions regarding power lines are not followed properly.

Power Lines

Do not operate the machine near energized power lines. All local, state/provincial and federal regulations must be met before approaching power lines, overhead or underground cables, or power sources of any kind with any part of the carrier or attachment. Always contact the appropriate utility when operating near power lines. The lines should be moved, insulated, disconnected or de-energized and grounded before operating in the area.



Current in high voltage lines may arc some distance from the wire to a nearby ground. Keep all parts of the machine at least 50 feet (16m) away from power lines.

OPERATIONAL SAFETY



WARNING

Serious injury or death could result if warnings or instructions regarding hydraulic fluid pressure are not followed properly.

Use Care with Hydraulic Fluid Pressure

Hydraulic fluid under pressure can penetrate the skin and cause serious injury or death. Hydraulic leaks under pressure may not be visible.

- ✓ Keep unprotected body parts, such as face, eyes and arms as far away as possible from a suspected leak. Flesh injected with hydraulic fluid may develop gangrene or other permanent injuries.
- ✓ If injured by injected fluid see a doctor immediately.
- ✓ Wear safety glasses and protective clothing and use a piece of cardboard or wood when searching for hydraulic leaks.

Do Not Use Your Hands!
See illustration below.

- ✓ Hydraulic oil becomes hot during operation. Do not let hydraulic oil or components contact skin, as it could cause severe burns. Allow hydraulic components to cool before working on them. Use appropriate protective clothing and safety equipment. If burned, seek immediate medical attention.

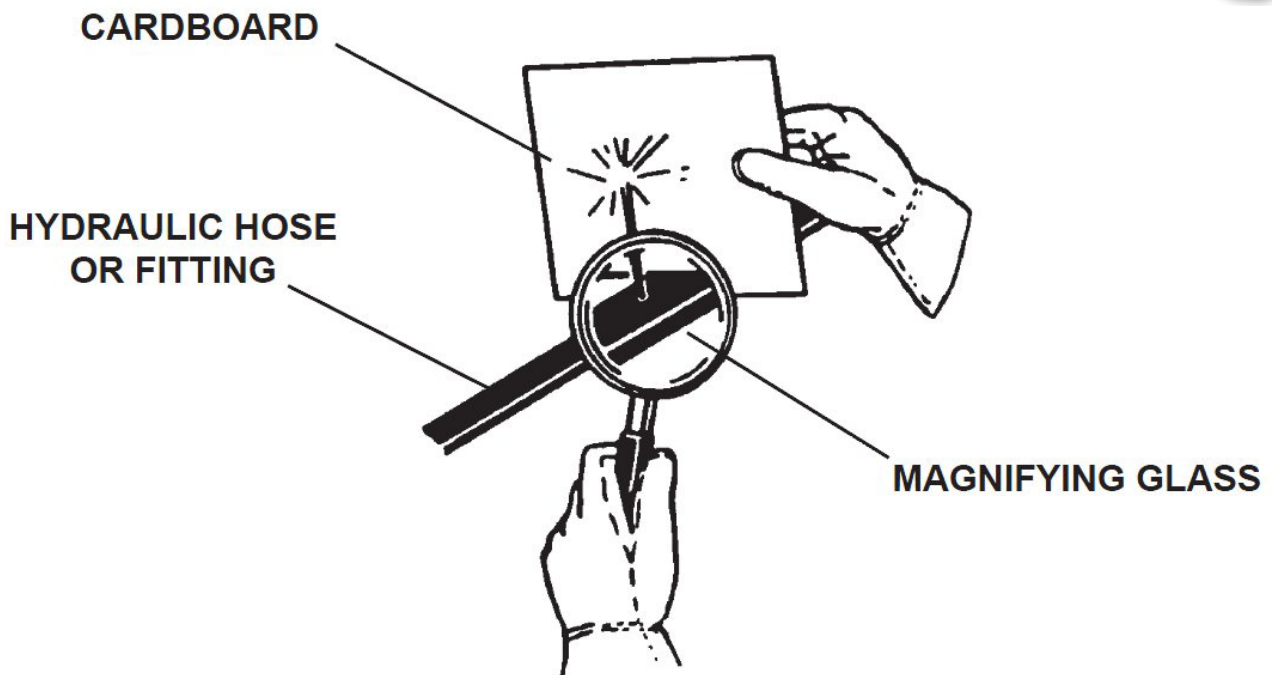

OPERATIONAL SAFETY

Prioritized Oil Flow

Equipment operators must ensure there is prioritized oil flow to the main valves in overhead operations or high reach conditions.

Emergency Situations

Always be prepared for emergencies. Make sure a fire extinguisher is available. Be familiar with its operation. Make sure to inspect and service the fire extinguisher regularly. Make sure a first aid kit is readily available.



Unsafe Conditions

Do not operate if an unsafe condition exists. Stop operation immediately, shut down the machine and report the unsafe condition to the proper authority. Equipment operation and maintenance practices directly affect your safety and the safety of those around you. Always use common sense while operating and be alert to unsafe conditions.

Crystalline Silica Dust

It is recommended to use dust suppression, dust collection and if necessary, personal protective equipment during the operation of any attachment that may cause high levels of dust.

 Exposure to respirable crystalline silica dust along with other hazardous dusts may cause serious or fatal respiratory disease.

IMPORTANT: Concrete and masonry products contain silica sand. Quartz, which is a form of silica and the most common mineral in the Earth's crust, is associated with many types of rock.

Some activities that may have silica dust present in the air include demolition, sweeping, loading, sawing, hammering, drilling or planing of rock, concrete or masonry.

It is recommended to use dust suppression (such as water) or dust collection (such as a vacuum) along with personal protective equipment if necessary during the operation of any attachment that may cause high levels of silica dust.



OPERATIONAL SAFETY



WARNING

Using your Genesis attachment in unauthorized applications may create an unsafe situation and will void the warranty.

Process Material Safely

- Do not pull down structures with your Genesis attachment. Doing so may cause falling debris or material may break free and exceed the capacities of the carrier, causing a tipping hazard.
- The rotator should only be used for positioning your Genesis attachment. Do not use the rotator to pry or break material.

Lift the Load Safely

- The hydraulic system has been preset and tested by your dealer. Do not alter hydraulic settings without consulting an authorized Genesis dealer or the Genesis Service Department. Doing so will void the warranty and may cause structural damage, accidents or tipping.
- Make sure the load is held securely in the tines. Do not move a loaded attachment if load is loose or dangling. Make sure the load is pinched between the tines – never cradle a load.

Place the Load Safely

- Do not move the attachment, or anything held in the tines, over people, equipment or buildings. Place the load gently. Do not throw or drop the contents.
- Operate the controls smoothly and gradually. Jerky controls are hazardous and may cause damage to the carrier.
- Avoid fire hazards. Keep the area clean. Remove all flammable materials from the area during any welding or heating process. Have a fire extinguisher nearby and know how to use it.
- Never substitute pins or bolts. Use factory supplied pins. Replace all bolts with the same size and grade. Failure to do so may cause serious injury or death.
- Use your Genesis attachment only as directed in this manual. Do not use the attachment to lift and move other objects. Doing so may cause instability and tipping.

SERIAL NUMBER LOCATION

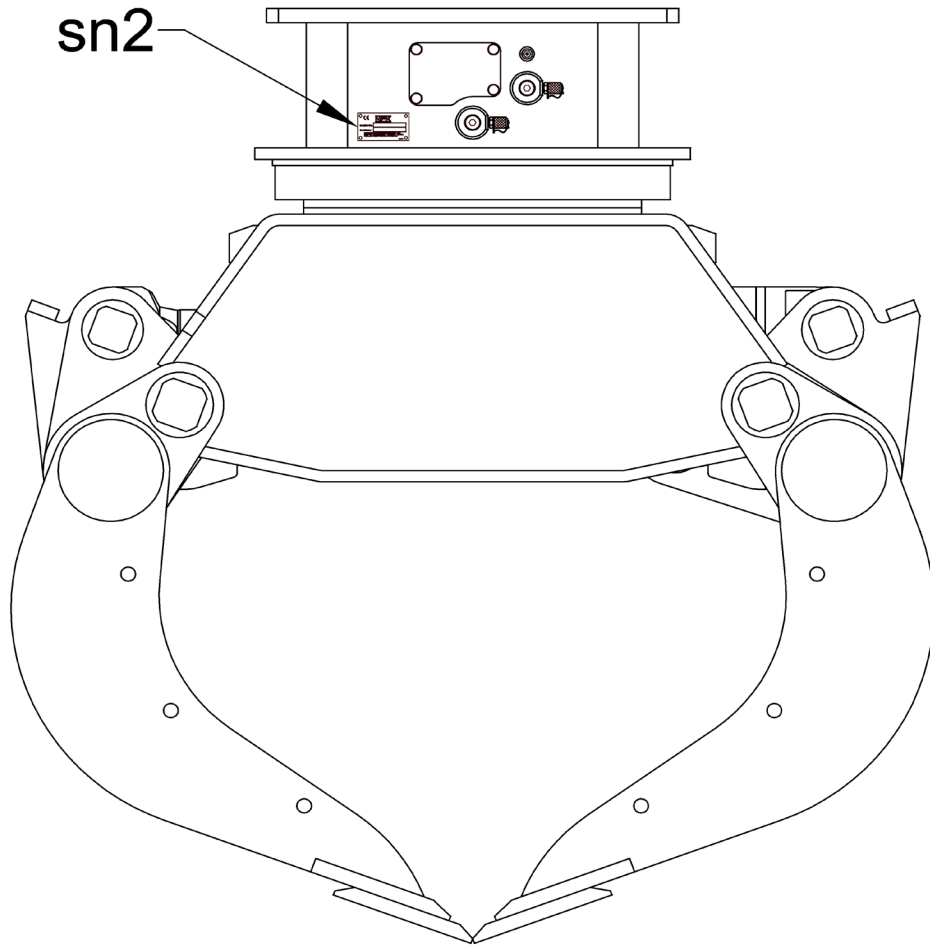

MAINTENANCE SAFETY

Only trained and authorized persons should perform maintenance on the attachment. To be qualified, you must understand the instructions in this manual, have training, and know the safety rules and regulations of the job site.

Do not alter the physical, mechanical or hydraulic operation of the attachment. Doing so may cause a dangerous situation for yourself and those around you and will void the warranty.

Do not attempt repairs you do not understand. If any questions arise regarding a safety or maintenance procedure, contact Genesis or your Genesis dealer.

Read this entire manual. All personnel must understand the maintenance and safety procedures.

Use only Genesis supplied replacement parts. Genesis specifically disclaims any responsibility for bodily injury or attachment damage that results from the use of parts not sold or approved by Genesis.

Use extreme caution in handling. A fully assembled grapple can weigh over 2 tons. Sub-assemblies range in weight from hundreds to thousands of pounds. To avoid bodily harm, use lifting and securing mechanisms of adequate capacity to support loads. Seek the aid of an assistant as much as possible, and always when handling heavier sub-assemblies.

The supplied safety bar (t79) **MUST** always be installed during transport, repairs, dismounting and mounting to the carrier, changing the cutters and all other routines at the attachment (GZ).

Follow the maintenance schedules in this manual. Extreme conditions may dictate shorter maintenance intervals.

Do not exceed bolt torque specifications.

Do not weld on structural components without consulting Genesis. Doing so may cause structural failure and void the warranty.

Do not operate an attachment without the case-drain line properly installed if the attachment uses a rotation system that requires a case drain. Doing so will cause immediate failure of the rotate motor and gearbox.

Do not work on the attachment before ensuring it will not move. Completely lower the boom to the ground or a rest position and relieve hydraulic pressure.

Never operate poorly maintained equipment. When maintenance is required, repair or replace parts immediately. When removing or installing mounting pins, beware of flying metal chips.

Do not operate under unsafe conditions. If an unsafe condition arises during operation, immediately shut down the equipment and report the situation to the proper authority.

Pinch Points & Crush Points

During maintenance or servicing, lifting the attachment by the top pins may cause the attachment to unexpectedly close, creating a crushing point. The grapple and tines must be properly blocked during maintenance. With the grapple hydraulic system drained of oil, this condition may cause the unexpected movement.

Performing Maintenance

Prior to maintenance, make sure the attachment is properly blocked to prevent accidental rotation. Do not rely on the rotation motor or other rotation components to inhibit movement during maintenance or servicing. Always perform appropriate Lockout/Tagout procedures.

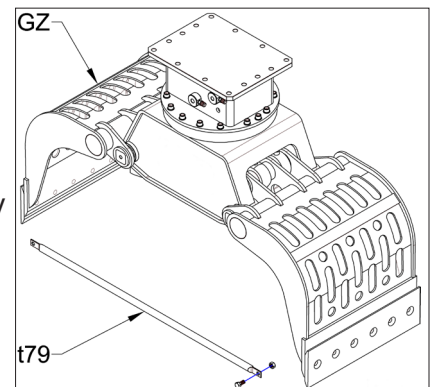

MAINTENANCE SAFETY

Do not work on any hydraulic lines or components while they are pressurized. Escaping hydraulic fluid can penetrate the skin, causing serious injury or death. Relieve pressure before performing maintenance. Keep hands and body parts away from pin holes and nozzles, which eject fluids under high pressure. Use a piece of cardboard to search for leaks.



If fluid is injected into the skin, seek medical assistance immediately from a doctor familiar with this type of injury.

NOTICE

See “Use Care with Hydraulic Fluid Pressure”, page 13

Hydraulic oil becomes hot during operation. Do not let hydraulic oil or components contact skin, as it could cause severe burns. Allow hydraulic components to cool before working on them. Use protective clothing and safety equipment.



Remove paint before welding or heating. Hazardous fumes/dust can be generated when paint is heated by welding, soldering or using a torch. Do all work outside or in a well ventilated area and dispose of paint and solvent properly.

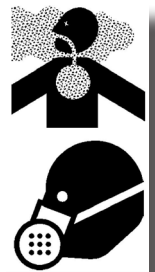

When sanding or grinding paint, avoid breathing the dust. Wear an approved respirator. If you use solvent or paint stripper, remove stripper with soap and water before welding. Remove solvent or paint stripper containers and other flammable materials from area. Allow fumes to disperse at least 15 minutes before welding or heating.

Avoid fire hazards. Keep the area clean. Remove all flammable materials from the area during any welding or heating process. Have a fire extinguisher nearby and know how to use it.



Never substitute pins or bolts. Use factory supplied pins. Replace all bolts with the same size and grade. Failure to do so may cause serious injury or death.

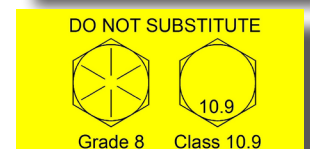

MAINTENANCE SAFETY

Maintenance of and repairs to the attachment should be performed by an experienced service technician, thoroughly familiar with all standard practices and procedures, and most importantly, all safety precautions. The following is a review of common standard practices to be followed when working with hydraulic equipment and is not meant to be all-inclusive. Rather, this review is presented as a reminder as to some of the unique characteristics of hydraulic equipment.

The prevention of foreign contaminant damage is critical when working with hydraulic equipment. Protect exposed holes and parts to guard against entry of contaminants. Install metal or plastic plugs/caps where applicable to prevent entry of debris into the hydraulic system.

Mark the location and position of mating parts as an aid to re-assembly. Mark corresponding parts uniquely to reflect their relationship, including proper location, position, orientation, and/or alignment.

During assembly, observe all markings made during disassembly, and all corresponding features of mating parts to ensure proper location, position, orientation, and alignment.

During disassembly of a sub-assembly, place removed components on a clean, dry surface, in proper relative position as an aid in re-assembly.

Always inspect threaded areas on components. Repair or replace as required. Never apply uncured thread adhesive to a fastener that has cured adhesive on it. Clean the fastener and the threaded bore. A tap and die may be helpful for this task. Be sure to remove loose debris from the threaded bore.

Use care to avoid scratches, nicks, dents or other damage to machined surfaces of mating components.

When securing a component, always tighten cap screws gradually in an opposing pattern, applying the specified torque.

Grease can be used to temporarily hold a part in place while the abutting part is placed into position.

Always use common sense and exercise standard safety precautions when working with all tools and equipment required to maintain, repair or troubleshoot the attachment.

MAINTENANCE

Performing scheduled maintenance will promote safe, reliable operation of your attachment. Use maintenance procedures described in this manual. If you are not able to safely and competently perform these procedures, have a Genesis dealer perform them.

Daily Inspection and Maintenance

- Grease all lubrication points. Use a lithium-based premium EP #2 in normal conditions above 32° F (0° C). Use Grade 0 in temperatures below freezing. **Do not use grease containing Molybdenum (Moly).** Genesis GLG-2® anti-wear, extreme-pressure lithium grease, PN 6302601, is recommended for all temperature conditions. See page 25 for lubrication point locations.
- Check for oil leaks at the cylinder piston rod and all of the hoses and fittings.
- Check all fasteners for looseness. Retighten if necessary.
- Inspect all welds and repair as necessary.
- Inspect the hydraulic hoses for wear, damage or oil leakage.

Arm Maintenance

Check for wear of the replaceable cutters (dg3 and dg4). If the cutters no longer touch, they must be replaced. The diagram below shows new (CY) and worn (CZ) cutters.

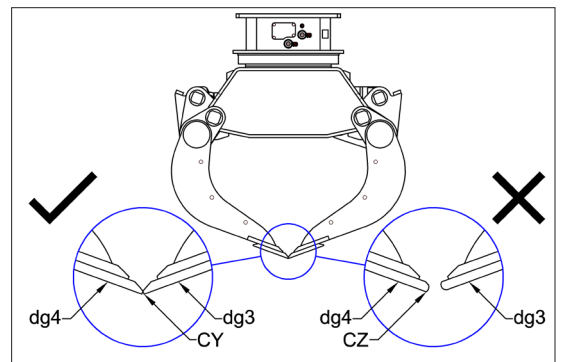

Frame Maintenance

Inspect frame welds for cracks or other deformities.

Frame Crack Repair

Drill a 3/16" (5 mm) hole through the plate at the end of the crack to prevent further crack propagation.

Grind out the crack and weld as shown. Use AWS E7018 or equivalent welding rod.

For plate sizes up to 3/4" (20 mm) thick, use the weld joint shown.

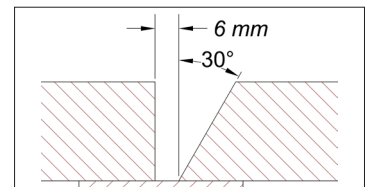
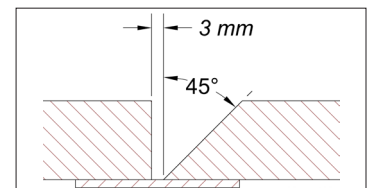

For plate sizes over 3/4" (20 mm) thick, use weld joint shown.

22 - Direction of grinding
23 - Direction of principle stress

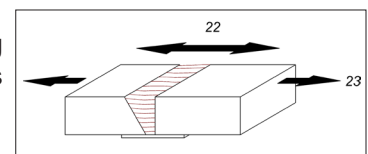

Grind weld flush as shown.

NOTICE

Extreme operating conditions may require shortened maintenance intervals.

SLEWING RING MAINTENANCE

Measuring Maximum Axial Movement

While the unit is attached to the excavator, position the grapple in the vertical position.

Using a dial indicator (t40), lock the base of the dial indicator onto the lower frame. Indicate the other end of the dial onto the top bracket face as shown. Using the excavator, slightly rock the grapple back and forth using slight stick movement. Note the movement shown by the dial. Take this reading (d59) in four places. If your readings are greater than shown, contact the Genesis Service Department at 715-395-5252.

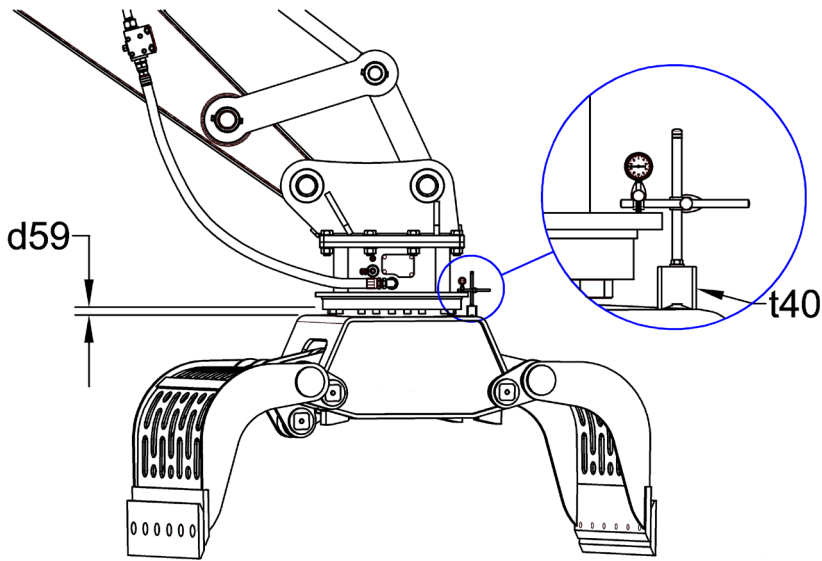

Model	New Maximum inch (mm)
All	<0.010 (0.25)
Model	Maximum Allowable Wear inch (mm)
All	0.138 (3.50)

ROTARY JOINT MAINTENANCE

Hydraulic Rotary Joint Assembly

The hydraulic rotary joint assembly (BN) is mounted inside the swivel top assembly (m27) which is under the top bracket (m7) that pins to the carrier and is bolted to the slewing ring (BT) which rotates the grapple's main frame. Hydraulic oil for both open and close operations passes through it. The rotary joint assembly consists of two main parts, the spindle case, which contains the oil seals, and the spindle, which rotates the grapple's main frame.

Seal Leakage

External leakage or internal (bypassing) of hydraulic oil will require the replacement of the seals in the rotary joint assembly. For external leakage, review the seal replacement procedure in the next section. If internal leakage is suspected, see below.

Testing the Rotary Joint Seals for Internal Leakage

If internal seal leakage is suspected, before disassembling the rotary joint assembly (BN), the counterbalance valve cartridge (cb1) pressure setting should be checked. Internal leakage will most likely prevent the unit from reaching relief pressure in the close function. The relief cartridge is located below the rotary joint in a block that the hose connections to the cylinder are located. Access to the relief valve cartridge is through the cover plates of the swivel top assembly.

Note: Before attempting to adjust the relief setting, check that the relief valve cartridge has not loosened in the block.

Procedure

Install a 0 – 5,000 psi gauge (g8f) in the Genesis shut-off (k4) located on the carrier stick. Close the arms, keep the function activated and read the pressure. Compare the pressure reached with the specifications for your GHG model (GZ). If the proper relief pressure cannot be reached, you must disassemble the rotary joint to check for failed seals.

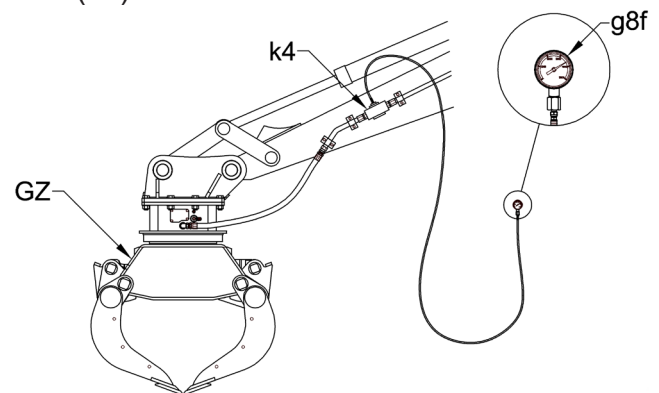
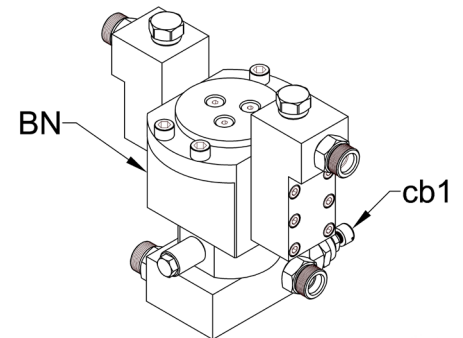
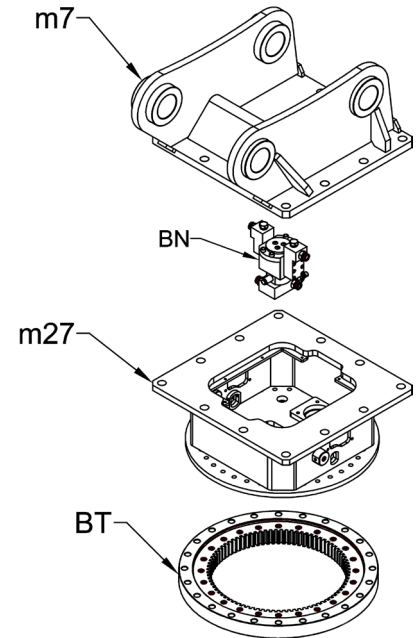

ROTARY JOINT MAINTENANCE

CAUTION

The GHG arms (dg1 and dg2) should be open and the safety bar (t79) installed during repair. Close the Genesis shut-off valves on the carrier stick.

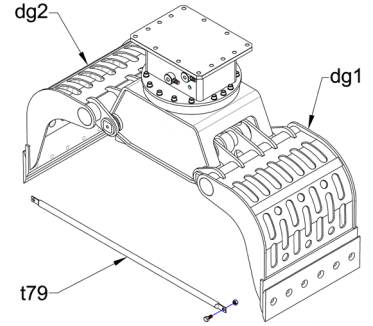

Rotary Joint Seal Replacement

Step 1

- Remove the top bracket from the swivel flat top assembly.
- Remove the joint fitting adapter fittings (m44) from the spindle case manifold blocks.
- Remove the hoses (AO) from the spindle base manifold.
- Remove the bolt (AF) and spacer (ZZ) from the spindle base manifold.
- Remove the four mounting bolts (AF1) from the spindle case.
- Pull the rotary joint assembly (BN) from the swivel flat top assembly.

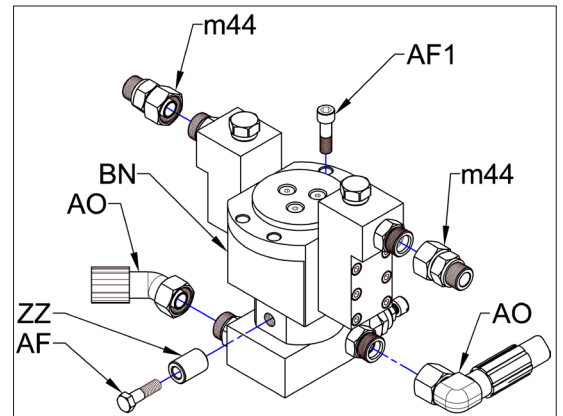

Step 2

- Remove the three flat head socket screws (AF9).
- Remove the top plate (CH) and O-ring (RR) from the spindle case (BZ).
- Remove the spindle case and O-ring from the spindle (CA).

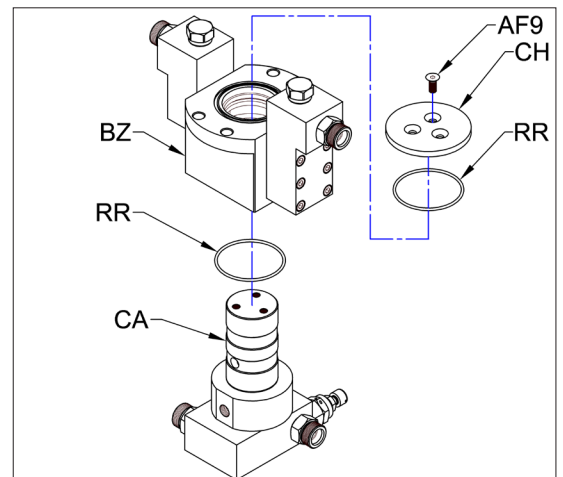

ROTARY JOINT MAINTENANCE

Rotary Joint Seal Replacement (cont'd)

Step 3 - Inspection

Visually inspect the sealing surfaces of the spindle (CA) for damage, which may hamper the ability of the main seals to seal.

Polishing the surfaces (120) may clean up light scratching. Heavy scratching or galling may indicate rotator bearing play.

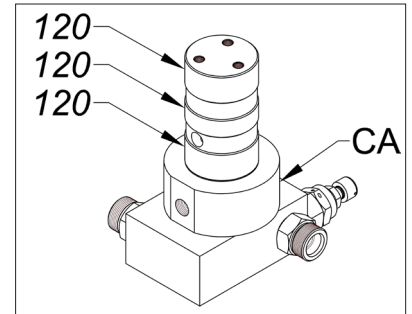

Step 4 - Seal Removal and Replacement

Sealing is accomplished by using main seals, which ride against the spindle and glide bearings.

Remove the main seals and glide rings with a seal pick (note the proper placement of main seals and glide bearings).

Check the grooves (118) in the spindle case (BZ) for burrs or scoring damage. Light grinding or polishing may be required.

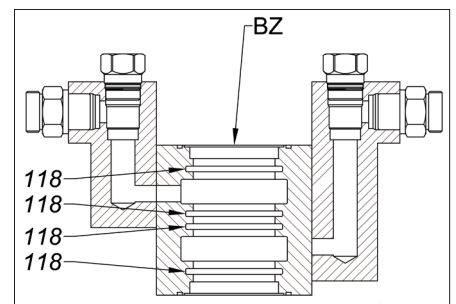

Step 5 - Rotary Joint Reassembly

- Lubricate the main seals (dg8), glide bearings (dg7) and O-rings (RR) with grease.
- Install the main seals into the spindle case (BZ) first.
- Install the first O-ring and glide bearing to the underside of the spindle case.
- Slide the spindle case over the spindle (CA).
- Install the second glide bearing and O-ring.
- Install the cover plate (CH) and three flat head socket screws (AF9). Make sure the counterbalance valve cartridge (cb1) is tight.

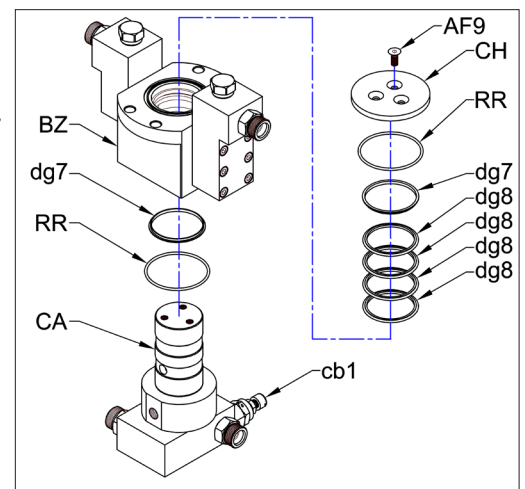

LUBRICATION POINTS



Shut off excavator and disable hydraulics per OEM instructions before greasing.

Use a lithium-based premium EP #2 in normal conditions above 32° F (0° C). Use Grade 0 in temperatures below freezing. **Do not use grease containing Molybdenum (Moly).** Genesis GLG-2[®] anti-wear, extreme-pressure lithium grease, PN 6302601, is recommended for all temperature conditions.

Grease Locations

- GR1** Cylinder rod pin: one lubrication point located at drive arm attachment end. 10 strokes from grease gun every 4 hours.
- GR3** Jaw pivot pin: one lubrication point for each pin, located on main frame. 15 strokes from grease gun per fitting every 4 hours.
- GR4** Slewing ring/pinion teeth: three lubrication points on outside diameter of the slewing ring. 5 strokes from grease gun per fitting once per shift.
- GR5** Motor pinion: one lubrication point. 5 strokes from grease gun once per shift.
- GR6** Cylinder base end pin: one lubrication point located at arm attachment end. 10 strokes from grease gun every 4 hours.
- GR9** Link plate pivot pins: one lubrication point each end per link. 10 strokes from grease gun every 4 hours.

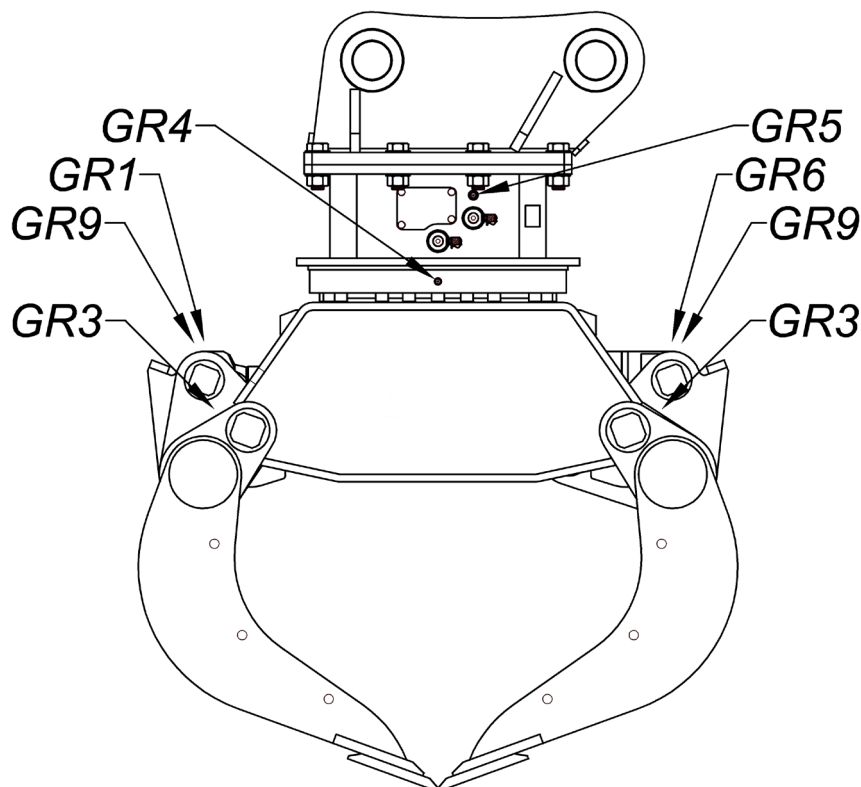

GENERAL WELDING GUIDELINES

Build-up and hard-surfacing are welding procedures that protect the parent material of the arms and keep the tool in good condition. Build-up is the welding procedure that restores the arms to their original shape and increases the life of the attachment. Hard-surfacing is the welding material added over the parent material (or build-up material) to create a wear-resistant surface.

Welding should not be performed until the arms are work-hardened. Work-hardening can take up to 80 hours.

Welding Ground Clamp

Disconnect all battery ground cables or shut off master battery switch, if equipped.

Failure to do so may cause excavator electrical problems, including permanent damage to onboard computer systems.

Connect ground clamp as close as possible to the area being welded without allowing current to pass through the pivot pins, cylinder pin, cylinder, swivel, motor or slewing ring.

If you are welding on the frame, connect weld clamp to the frame. If you are welding on the arms, connect to the arms but not to the cylinder clevis. If needed, weld a piece of steel to the area for the grounding clamp and cut the piece off when welding is completed.

Welding Rules

Before you begin:

- Wearing an approved respirator, grind the area to clean it and remove all existing hard-surfacing.
- Preheat area to 350° F (177° C). Maintain this temperature throughout the procedure. Do not exceed 450° F interpass temperature.

During welding:

- Always grind and weld with the grain of the material.
- Peen each weld pass to relieve stress and harden the welds.
- Do not undercut the ends of the welds.

After welding maintenance is complete:

- Cover the area with a heat blanket and allow it to cool slowly, approximately eight hours.
- Do not put the attachment into operation until the welds have been allowed to cool.

HARD-SURFACING

Do not apply hard-surfacing directly to the parent material as this could cause toe cracking, and the hard-surfacing will break away.

Procedure:

Follow the General Welding Guidelines and Rules.

Apply a single pass stringer bead pattern, with the grain, using E7018 electrode. Peen each pass.

Do not apply a stringer directly on the edge. Start the first pass 1/4" from the edge.

Stagger the ends of the stringer welds so they do not end in a straight line.

Cap each stringer bead with one pass of GenWire or GenRod to hard-surface. Do not apply more than two layers of hard-surfacing. Peen each pass.

Grind the ends of all stringer welds, with the grain to taper 1" to 1-1/2" (25 - 38 mm) to the parent material.

See the previous page for hard-surfacing illustrations and instructions specific to each area of the jaws.

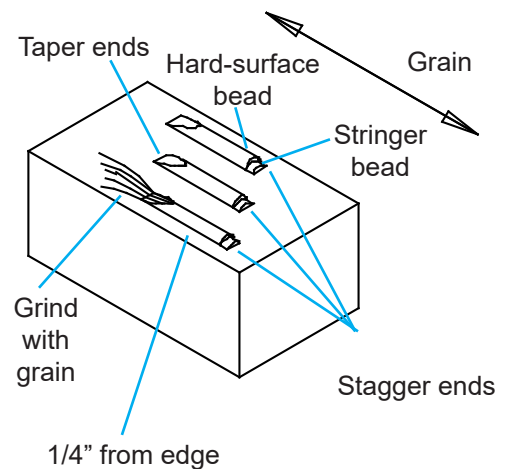

HYDRAULIC FLOW AND PRESSURE

Flow and Pressure Specifications

Operating the attachment below the recommended flow and/or pressure range will adversely affect performance and may damage the rotate motor. Rotation is 360°.

Operating the attachment above the recommended flow and/or pressure range may damage the attachment and its hydraulic components.

Main Jaws

Model	Oil Flow		Pressure	
	GPM	LPM	PSI	BAR
GHG 4	4 - 9	15 - 35	2,610 - 3,770	180 - 260
GHG 6	5 - 10	20 - 40	2,900 - 4,060	200 - 280
GHG 9	8 - 13	30 - 50	3,190 - 4,640	220 - 320
GHG 14	8 - 16	30 - 60	3,625 - 5,075	250 - 350
GHG 16	16 - 26	60 - 100	3,625 - 5,075	250 - 350
GHG 20				
GHG 25				
GHG 30	21 - 32	80 - 120		
GHG 40				
GHG 50	26 - 37	100 - 140		

Rotation

Model	Oil Flow		Pressure	
	GPM	LPM	PSI	BAR
GHG 4	3 - 6	12 - 22	1,500 - 2,000	103 - 138
GHG 6	2.5 - 4	10 - 15	1,450 - 1,885 100 - 130	
GHG 9	3 - 4	12 - 15		
GHG 14	5 - 8	20 - 30	1,450 - 2,030	100 - 140
GHG 16				
GHG 20	8 - 13	30 - 50		
GHG 20 Optional Single Motor	5 - 8	20 - 30		
GHG 25	8 - 13	30 - 50		
GHG 25 Optional Single Motor	5 - 8	20 - 30		
GHG 30	8 - 13	30 - 50		
GHG 30 Optional Single Motor	5 - 8	20 - 30		
GHG 40	8 - 13	30 - 50		
GHG 40 Optional Single Motor	5 - 8	20 - 30		
GHG 50	8 - 13	30 - 50	1,450 - 2,320	100 - 160

HYDRAULIC INSTALLATION

Hydraulic Lines

Typically, the pressure line to close is arranged on the left side of the boom and the open line is on the right side.

Shut-Off Valves

Some hydraulic installation kits use two shut-off valves (k4) on the dipper stick (k1) of the carrier. These valves control the hydraulic oil going to the close side (m3) and the open side (m4) from the grapple.

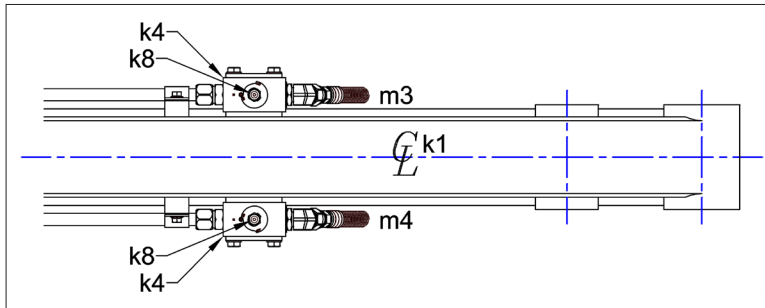

Pressure test ports (k8) are in the shut-off valves (k4). Each shut-off valve has an on (k5) and an off (k6) position.

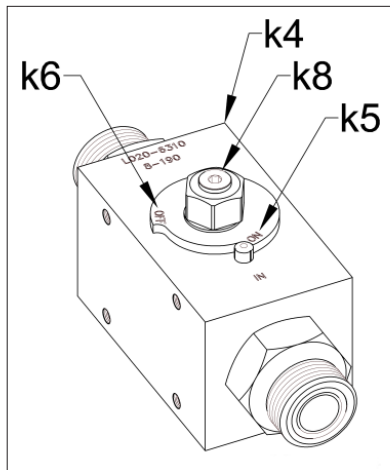

HYDRAULIC INSTALLATION

Port Connection Diagram

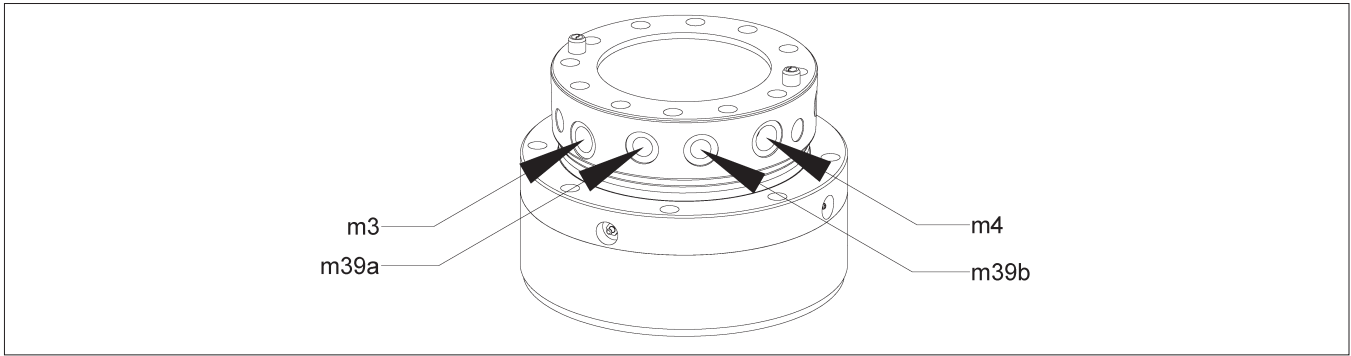
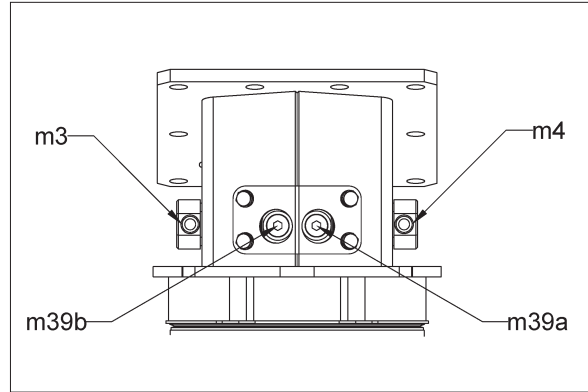
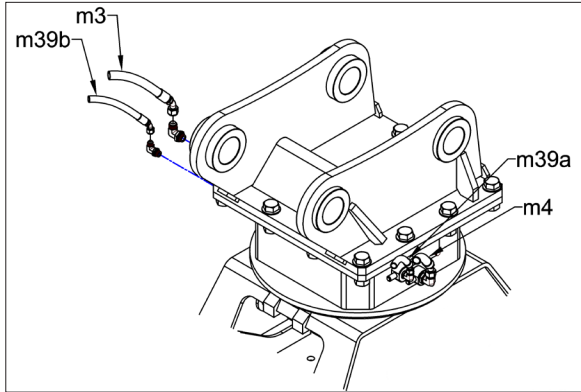

m3	Hose: arm close
m4	Hose: arm open
m39a	Rotation Hose: for clockwise movement
m39b	Rotation Hose: for counterclockwise movement

Model	Open/Close	Rotation
GHG 4	8 JIC	8 JIC
GHG 6		
GHG 9		
GHG 14		
GHG 16	12 JIC	
GHG 20		
GHG 25		
GHG 30		
GHG 40		
GHG 50		

HYDRAULIC CIRCUITS

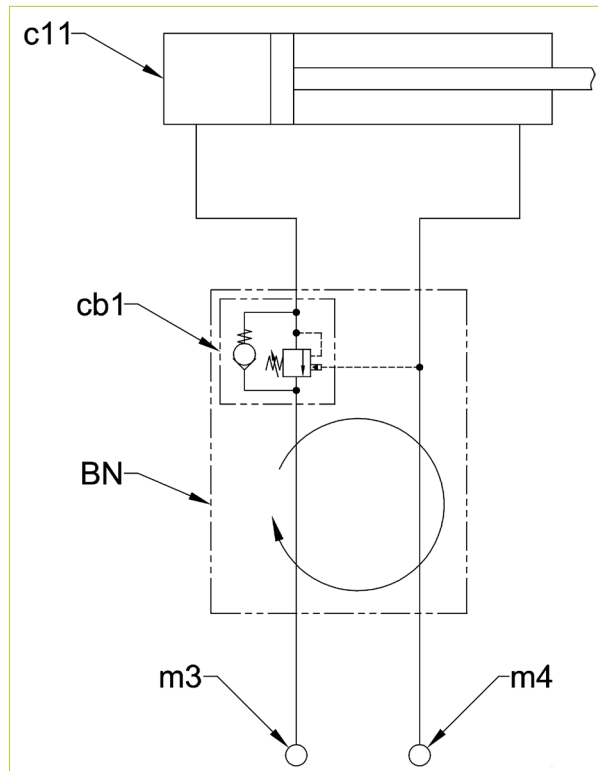

Cylinder Hydraulic Circuit

BN	Rotary Joint Assembly
c11	Cylinder
cb1	Counterbalance Valve
m3	Arm Close Port
m4	Arm Open Port

HYDRAULIC CIRCUITS

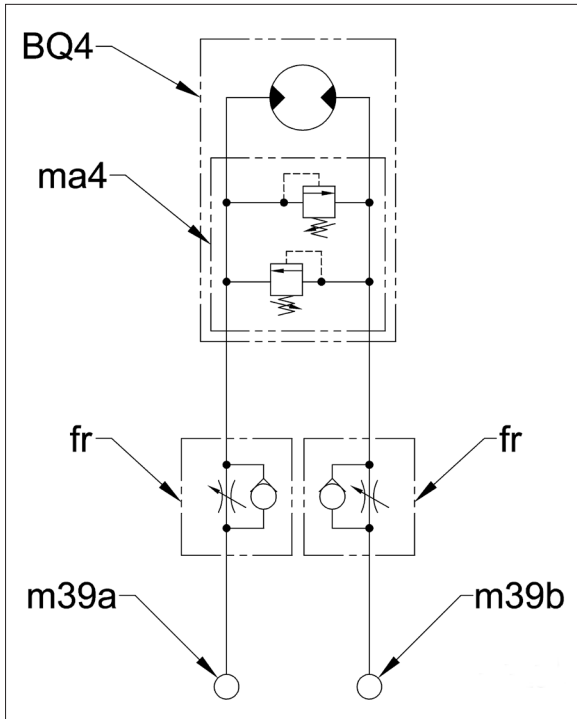

Single Motor Hydraulic Circuit

BQ4	Hydraulic Motor
fr	Flow Regulator
ma4	Cross-port Relief
m39a	Clockwise Rotation Port
m39b	Counter-Clockwise Rotation Port

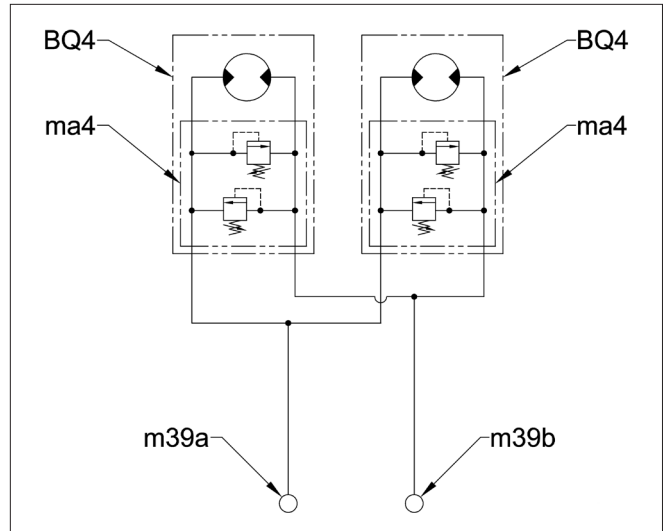

Dual Motor Hydraulic Circuit

BQ4	Hydraulic Motor
ma4	Cross-port Relief
m39a	Clockwise Rotation Port
m39b	Counter-Clockwise Rotation Port

GRAPPLE INSTALLATION

Genesis Mounting Installation Kits include the parts required to adapt the GHG to the excavator stick or arm. The kits include all necessary stick and link pins, bolts, etc.

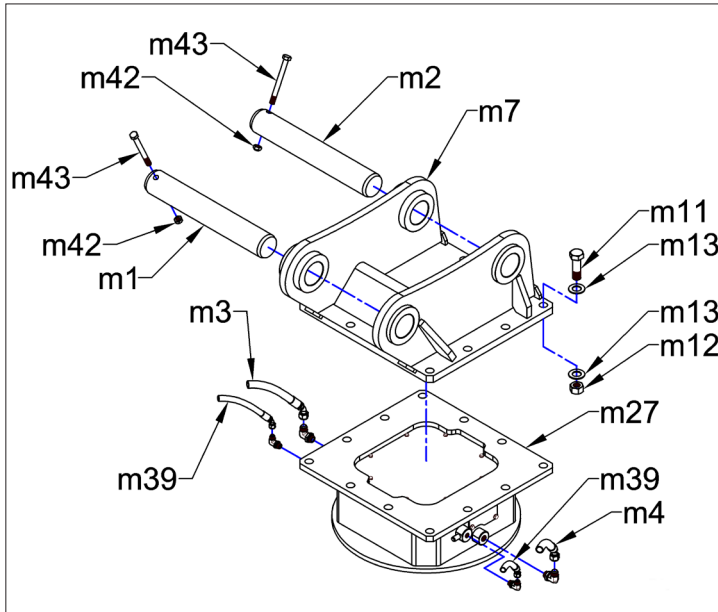

m1	Stick Pin (optional)
m2	Link Pin (optional)
m3	Whip Hose - Close (optional)
m4	Whip Hose - Open (optional)
m7	Top Bracket
m11	Bracket Bolt
m12	Hex Nut
m13	Washer
m27	Swivel Top
m39	Rotation Hose (optional)
m42	Hex Nut
m43	Pin Bolt

GRAPPLE INSTALLATION

Mounting to the Excavator

- Position the GHG on wood blocks (t20) as shown.
- Align the stick pin bore (m24). Install the stick pin (m1).
- Align the link pin bore (m25). Install the link pin (m2).
- Clean any dirt found on the hose connections, connect the whip hoses (m3 and m4) and the rotation hoses (m39).
- Open the shut off valves (k4).
- Remove safety bar.

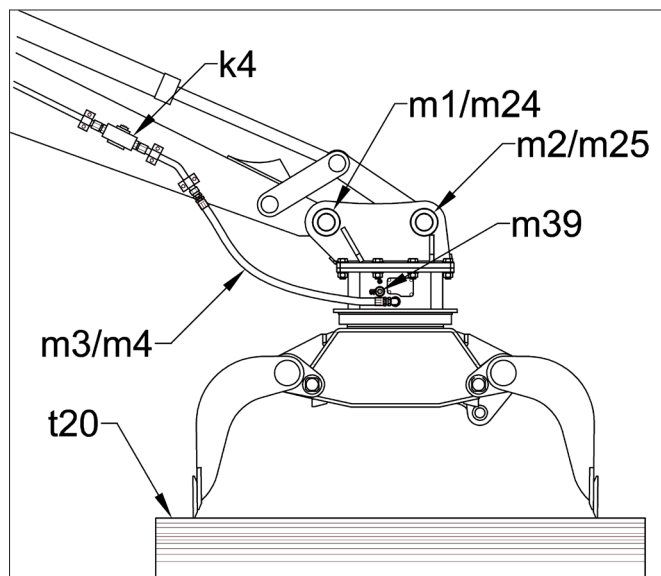

NOTICE

The hydraulic lines must be handled carefully to prevent contamination from entering the grapple or the carrier hydraulic system.

Removal from the Excavator

- Retract the cylinder to open jaws fully.
- Position the GHG horizontally on wood blocks (t20), as shown above.
- Install safety bar.
- Close the shut-off valves.
- Shut off engine and relieve all hydraulic pressure.
- Disconnect the hydraulic hoses before setting the GHG down. Install plugs in the hydraulic hoses and caps on the stick tubes to keep out contamination.

Grapple Storage

- Make sure the hydraulic hoses are plugged and stick tubes capped.
- Grease all lubrication points, see page 25.
- If stored outdoors, cover with waterproof tarp.

OPERATING TECHNIQUES AND PRECAUTIONS

Before operating the grapple, be sure to read the safety information and perform the daily and weekly maintenance as specified in this manual.

Do not operate the grapple without the demolition guards in place.

Do not lift or load beyond the capacity of the grapple or the excavator.

The GHG is designed for grabbing and moving materials that are on a solid base, under water or in a construction setting without causing danger to the surroundings or operators.

Do not use the GHG with the excavator cylinders fully extended (96) or retracted (97).

Do not strike, push, pull or scrape material with the GHG (DO1).

Do not pry, twist or pull with the excavator. The excavator should only be used to position and supply hydraulic power to the GHG.

For most efficient operation, open the jaw only wide enough to grasp the material. Grasp the material to be grabbed as deep into the throat of the GHG as possible. Do not force the material into the jaws.

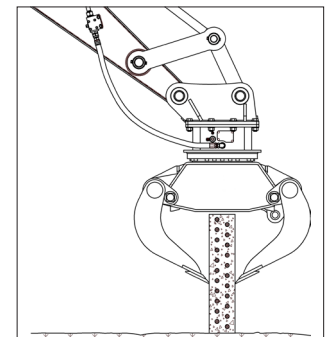
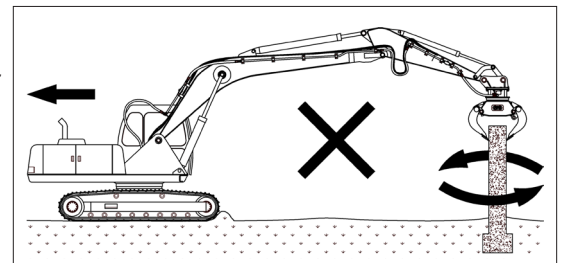
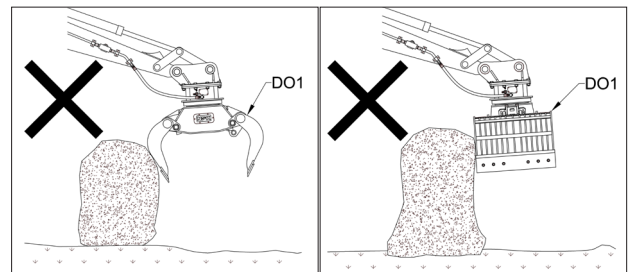
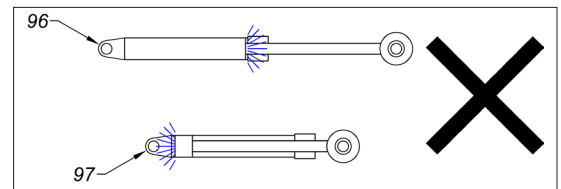
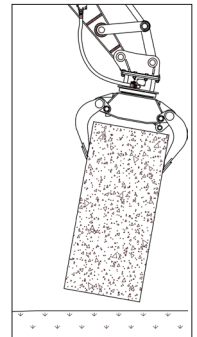
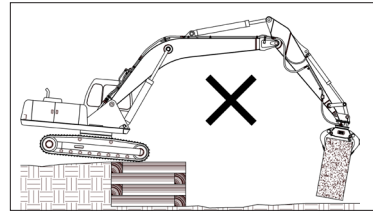

TROUBLE-SHOOTING GUIDE

Determine the Type of Problem

Performance problems are classified as loss of power or loss of cycle speed (assuming the problem is not due to misapplication).

Loss of power - GHG grabbing forces are determined by the operating pressure settings.

Loss of cycle speed - GHG cycle speed is determined by the hydraulic flow to the unit. The hydraulic installation circuit must be set to provide the correct oil flow.

Determine the Cause of the Problem

Technical problems are caused by either the GHG or the hydraulic circuit (carrier hydraulics or installation kit). Checking the hydraulic pressure and flow will determine if the problem is in the grapple or the carrier. If the pressures and flow available to the GHG are correct, the problem is in the grapple.

Guide for Power Loss

Power loss can be caused by a low carrier relief valve setting or a low grapple relief setting. Verify the correct relief valve settings of the carrier and the GHG. See the Relief Valve Checking and Setting section and troubleshooting chart.

Measuring Operating Pressures

Tools and equipment required:

Qty. 1 Pressure gauge: 0 – 5,000 psi (0 – 350 bar), for arm close circuit

Qty. 1 Test port adapter: to fit #4 SAE female port in the shut-off valve

Qty. 1 Test hose: rated for 5,000 psi (350 bar)

Relief Valve Checking and Setting

Some hydraulic installation kits provide shut-off valves (k4) with test ports (k8) in both arm open (m4) and arm close (m3) hydraulic lines. Install pressure test hoses in both the arm open and arm close test ports.

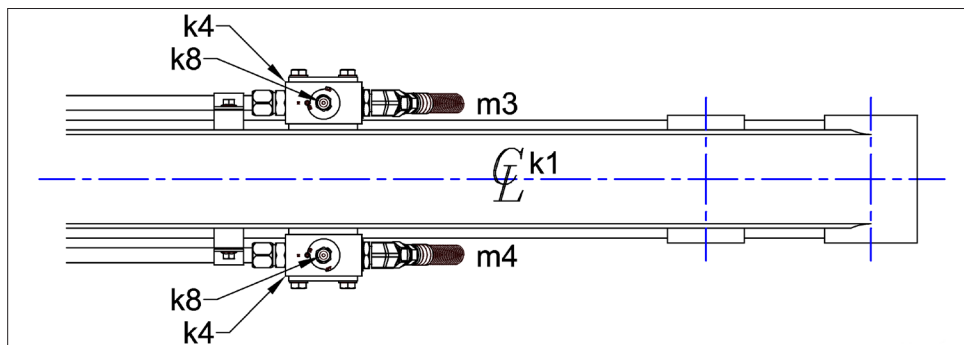

TROUBLE-SHOOTING GUIDE

Relief Valve Checking and Setting (cont'd)

The Carrier's Hydraulic Circuit Relief Valve

Verify the hydraulic circuit meets the GHG's (GZ) requirements; see Hydraulic Flow and Pressure page 28.

Install a 0 – 5,000 psi (0 – 350 bar) pressure gauge (g8f) in the #4 SAE test port (k8) on the arm close side and a 0 – 5,000 psi (0 – 350 bar) pressure gauge (g8b) in the #4 SAE test port on the arm open side located in both shut off valves (k4) at the end of the stick.

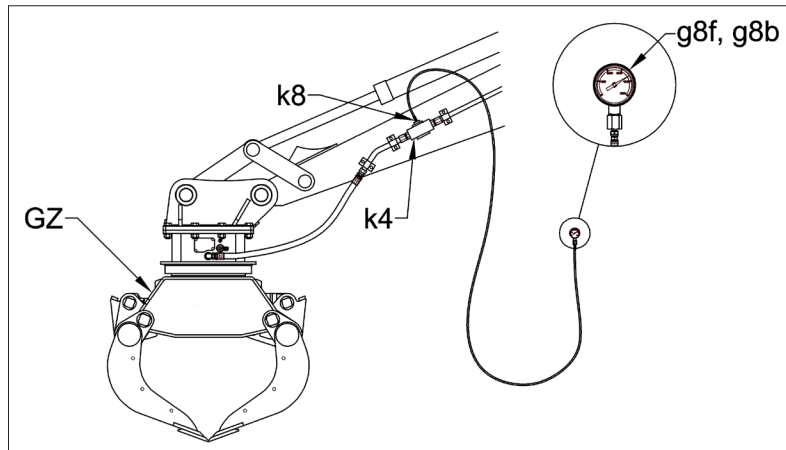

Turn the shut-off valves (k4) to the off position.

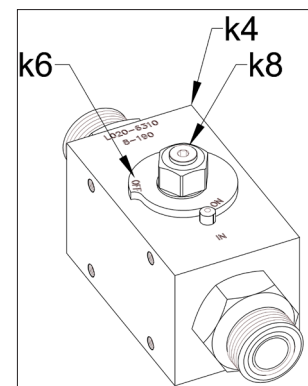

Start the carrier and set the throttle to the full position. Actuate the hydraulic circuit to close the GHG arms.

The pressure reading on the gauge should be a minimum of 500 psi (34 bar) above the GHG's relief valve setting, see Hydraulic Flow and Pressure page 28.

If the carrier's relief is not set at a minimum of 500 psi (34 bar) above the GHG's relief, reset or replace at this time.

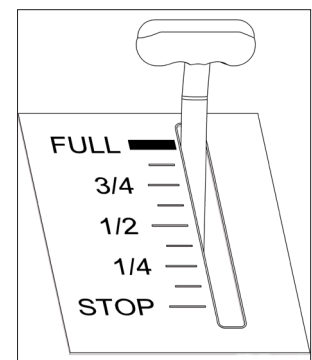

TROUBLE-SHOOTING GUIDE

Relief Valve Checking and Setting Procedure (cont'd)

The GHG's Counterbalance Valve

After the carrier's hydraulic circuit has been verified, check the GHG's counterbalance valve setting.

With the 0 – 5,000 psi (0 – 350 bar) gauge in the arm close side and the 0 – 5,000 psi (0 - 350 bar) in the arm open side of the stick, turn the shut-off valves (k4) to the on position (k5).

Start the carrier. Set the throttle to the full position then close the arms completely and hold for ten seconds. Check the psi (bar) reading on the gauge and compare to the GHG's specified counterbalance valve setting. If the reading is not per specification, see Hydraulic Flow and Pressure page 28 and reset the counterbalance valve cartridge. If you are unable to reset the counterbalance, refer to the trouble-shooting chart.

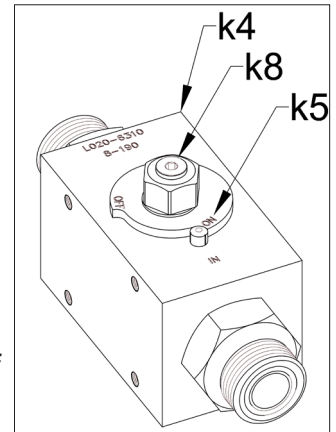

Counterbalance Valve Location

The counterbalance valve cartridge (cb1) is located in the manifold block, which is part of the rotary joint assembly (BN). See the unit's parts breakdown for the location of the rotary joint.

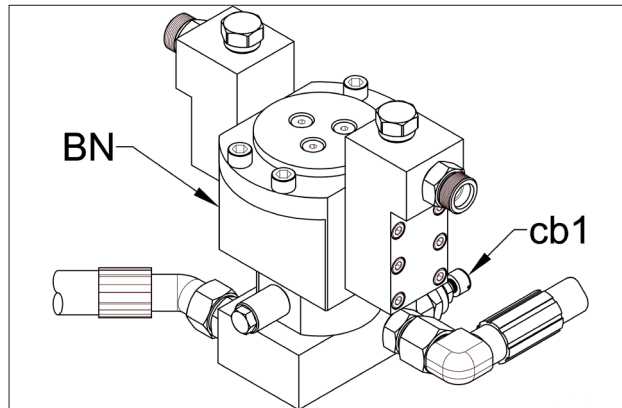

TROUBLE-SHOOTING GUIDE

Low Power

Problem	Cause	Check	Remedy
Operating pressure is less than 3,625 psi (250 bar).	Excavator hydraulic circuit relief valve	Measure the excavator circuit relief valve pressure with the left hand shut-off valve closed.	Adjust or replace the excavator circuit relief valve.
	Attachment relief valves	Measure the attachment relief valves with the shut-off valves open.	Replace the attachment relief valve.
		Check the relief valve cartridge for tightness.	Tighten the relief valve cartridge.
		Check the relief valve cartridge for mis-adjustment.	Re-adjust the relief cartridge.
		Check the O-rings and backup rings of the relief valve cartridge.	Replace the O-rings and backup rings of the relief valve cartridge.
		Check the seals between the open and close passages of the swivel manifold assembly.	Replace the seals in the swivel manifold assembly.
		Check the land areas for the seals in the swivel manifold assembly.	Repair the land areas or replace the spindle.

If additional assistance is required, call the Genesis Service Department at 715-395-5252.

TROUBLE-SHOOTING GUIDE

Slow Cylinder Speed

The GHG cycle times are controlled by the flow provided by the carrier's hydraulic circuit and are a direct result of the maximum published oil flow, see Hydraulic Flow and Pressure page 28.

If the arms will not open or close, be sure the right and left shut-off valves are open.

Checking Hydraulic Flow at Rated Pressure

Tools and equipment required:

Qty. 1 Pressure gauge: 0 – 5,000 psi (0 – 350 bar), for arm close circuit

Qty. 1 Test port adapter: to fit #4 SAE female port in the shut-off valve

Qty. 1 Test hose: rated for 5,000 psi (350 bar)

Qty. 1 Hydraulic flow meter: pressure loading type, 0 – 100 gpm (0 – 380 lpm) minimum capacity

Checking Hydraulic Flow at Rated Pressure

Install a pressure gauge in the shut-off valve of the close side (left) of the hydraulic circuit.

Install a flow meter (t36) between the GHG (GZ) close and open lines as shown.

Typically, the arm close line (m3) is on the left (from the operator's) seat and arm open (m4) is on the right.

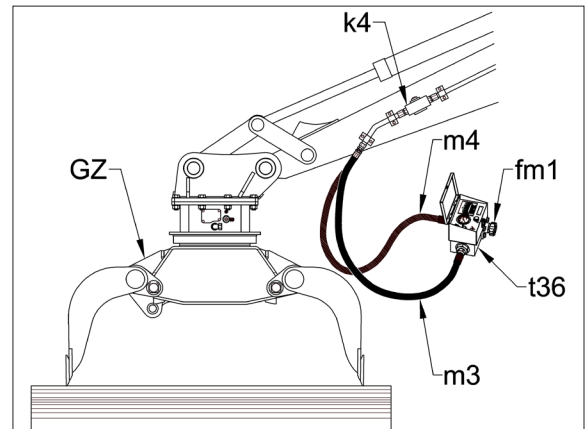

To determine return line pressure (pressure drop) open both shut-off valves (k4) and energize the arm close circuit. Measure the pressure with the load valve (fm1) of the flow meter in the full open position.

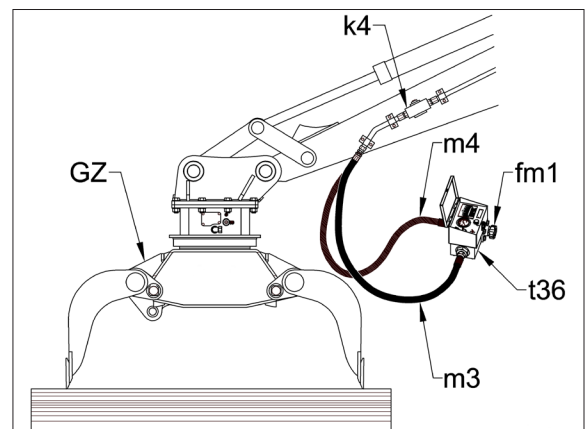

TROUBLE-SHOOTING GUIDE

Checking Hydraulic Flow at Rated Pressure (cont'd)

To determine the available flow and relief valve setting of the carrier, follow the steps below.

Adjust the load valve on the flow meter to zero restriction. Start the carrier and set the throttle to the full position.

Energize the close hydraulic circuit. Adjust the flow meter load valve until the system reaches about 1,000 psi (70 bar). Warm the hydraulic system of the carrier to normal operating temperature.

With the engine at full throttle and the flow meter set at zero pressure, energize the close circuit. Turn in the loading valve adjustment knob and record pressure and flow at regular intervals on graph paper. Record pressure on one axis of the graph and flow on the other. Increase pressure until the relief valve setting of the carrier is reached. This is the circuit flow chart.

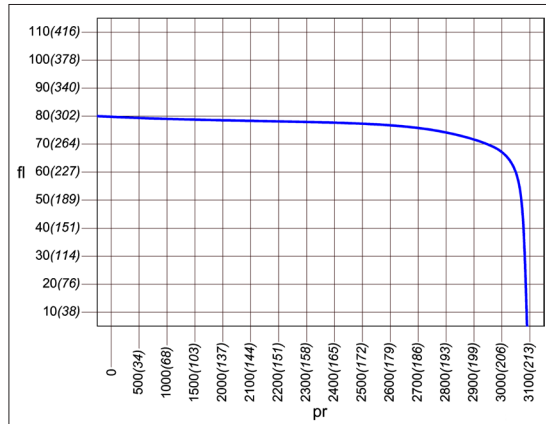
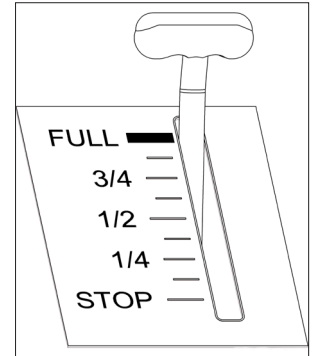

Set the flow meter at 1,000 psi (70 bar) and check the flow. See Hydraulic Flow and Pressure, page 28, for the correct flow for your GHG. If the reading on the flow meter does not match the GHG specification, adjust the carrier flow.

If the cycle speed is still too slow, see Slow Cylinder Speed trouble-shooting on page 42.

TROUBLE-SHOOTING GUIDE

Slow Cylinder Speed

Problem	Cause	Check	Remedy
Slow cylinder speed. Operating pressure okay. 3,625 psi (250 bar) minimum.	Carrier flow setting is low.	Check flow output of attachment hydraulic circuit at 1000 psi (69 bar).	Adjust control valve flow adjustment of carrier.
			Repair or replace the carrier's pump.
			Check attachment cylinder packing. Replace if required.
Slow cylinder speed. Operating pressure not okay. Less than 3,625psi (250 bar).	Carrier relief set too low. Set below 3,800 psi (262 bar).	Measure the excavator circuit relief valve pressure with the shut-off valve closed.	Adjust or replace the carrier's circuit relief valve.
	Attachment counterbalance valve cartridge.	Check the counterbalance valve cartridge for tightness.	Tighten the counterbalance valve cartridge.
		Check the O-rings and backup rings of the counterbalance valve cartridge.	Replace the O-rings and backup rings of the counterbalance valve cartridge.

If additional assistance is required, call the Genesis Service Department at 715-395-5252.

Jaw Drift

- Some drift may be experienced depending on the GHG's position.
- Acceptable drift may occur over a number of minutes.
- Rapid drift may indicate a problem with the GHG's cylinder, rotary joint assembly or the carrier's hydraulic circuit.

Determine if Jaw Drift is Occurring from a Bad Cylinder or the Carrier

Remove the hoses from the joint fittings on the outside of the GHG's frame and close the shut-off valves on the carrier.

Cap the joint fittings (#12 JIC).

If the jaw drifts, the problem is coming from the GHG's cylinder or rotary joint assembly. If no drift occurs, the problem is in the carrier's main control valve. Drift due to internal leakage of the carrier's main control valve may be inherent to the carrier and not solvable.

TROUBLE-SHOOTING GUIDE

Slow Rotation Speed

The rotation speed is a direct result of the amount of flow (gpm/lpm) supplied by the carrier rotation circuit. The chart below lists the approximate flow required.

Model	Rotation		Pressure	
	Oil Flow		PSI	BAR
	GPM	LPM		
GHG 4	3 - 6	12 - 23	1,500 - 2,000	103 - 138
GHG 6	2.5 - 4	10 - 15	1,450 - 1,885	100 - 130
GHG 9	3 - 4	12 - 15		
GHG 14	5 - 8	20 - 30	1,450 - 2,030	100 - 140
GHG 16				
GHG 20	8 - 13	30 - 50		
GHG 20 Optional Single Motor	5 - 8	20 - 30		
GHG 25	8 - 13	30 - 50		
GHG 25 Optional Single Motor	5 - 8	20 - 30		
GHG 30	8 - 13	30 - 50		
GHG 30 Optional Single Motor	5 - 8	20 - 30		
GHG 40	8 - 13	30 - 50		
GHG 40 Optional Single Motor	5 - 8	20 - 30		
GHG 50	8 - 13	30 - 50	1,450 - 2,320	100 - 160

Adjust the rotation flow so that it is within the guidelines shown for the model being tested.

Flows are checked at a normal operating pressure of 1,000 psi (70 bar). Cross-port relief valves rated at 2,500 psi (172 bar) are included in the hydraulic motor.



CAUTION

Excessive rotation speed will result in damage to the hydraulic motor, gearbox or bearing.

TROUBLE-SHOOTING GUIDE

Measuring Rotation Pressures

Tools and equipment required:

Qty. 1 Pressure gauge: 0 – 3,000 psi (0 – 210 bar)

Qty. 1 Gauge adapter fitting: 1/4" npt female x #6 JIC male
(Genesis part number NK023-6690)

Qty. 2 Swivel run tee fittings: #8 JIC

Qty. 2 Test hoses: rated for 3,000 psi (210 bar); #8 JIC female swivel one end and #6 JIC female swivel the other end.

Checking Rotation Pressure

Install gauges in the rotation circuit lines.

Position the GHG so it will not rotate.

Attempt to rotate the unit in both directions. Each gauge should read 2,000 psi (138 bar).

Rotation

Problem	Cause	Check	Remedy
Unit will not rotate.	Low or no flow.	Check hydraulic flow.	Adjust the carrier's flow to the attachment.
	Pressure setting of cross-port relief valves (ma4).	Check cross-port relief valve settings.	Adjust the cross-port relief valves on the rotation holding valve.
			Replace cross-port relief valves.
Broken pinion gear or hydraulic motor shaft.	Check pinion gear and hydraulic motor shaft.	Replace hydraulic motor or pinion gear.	
Unit will not hold position.	Pressure setting of cross-port relief valves.	Check cross-port relief valve settings.	Adjust the cross-port relief valves on the rotation holding valve.
			Replace cross-port relief valves.
	Broken pinion gear or hydraulic motor shaft.	Check pinion gear and hydraulic motor shaft.	Replace hydraulic motor or pinion gear.

TROUBLE-SHOOTING GUIDE

Rotation Speed Adjustment

For models GHG 9 - GHG 40 with the single motor option

The rotation speed can be adjusted clockwise and counterclockwise independently from each other.

1. Remove both covers (s9) from the side of the swivel top (m27).
2. When the covers are removed, two flow regulators (fr) will be visible.

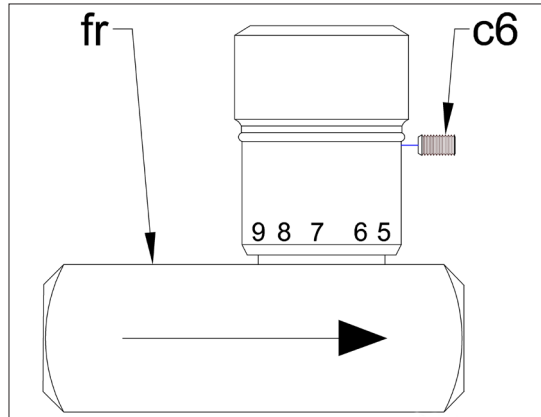

3. These regulators are locked with a (3/32") locking screw (c6). The screw must be loosened before the flow regulators can be adjusted.
4. By turning the adjustment knobs, you can either slow down or accelerate the rotation speed.

Be sure to tighten the locking screw when rotation speed adjustment is completed.

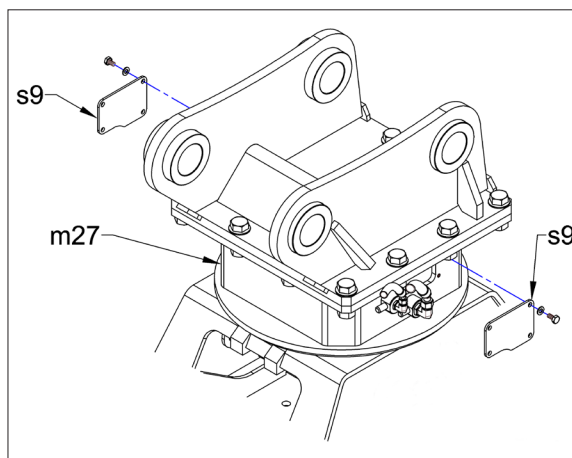

TROUBLE-SHOOTING GUIDE

Torque Charts

Use the following torque charts for your specific GHG model.

All fasteners will require lube or medium strength thread adhesive. Bolts must have their threads wire brushed or cleaned with a thread die; then cleaned with solvent; then cleaned with compressed air. Threaded holes must be cleaned with a tap; then cleaned with solvent; then cleaned with compressed air.

Do not use anti-seize compound on any fasteners unless otherwise noted.

Top Cover - HHCS

Model	Part Number	Bolt Diameter	ft. lbs.	Nm
GHG 4 - GHG 14	—	—	—	—
GHG 16 - GHG 50	N71008020	M8	19	25

Cover Plate - HHCS

Model	Part Number	Bolt Diameter	ft. lbs.	Nm
GHG 4 & GHG 6	N71008020	M8	19	25
GHG 9 - GHG 50	N71010020	M10	37	50

Safety Bar - HHCS

Model	Part Number	Bolt Diameter	ft. lbs.	Nm
GHG 4	N71012040	M12	81	110
GHG 6	N71016040	M16	207	280
GHG 9 - GHG 40	N71020040	M20	406	550
GHG 50	N71020045			

Support Bracket - HHCS

Model	Part Number	Bolt Diameter	ft. lbs.	Nm
GHG 4	—	—	—	—
GHG 6	N74012055	M12	81	110
GHG 9	N71012025			
GHG 14	—	—	—	—
GHG 16 - GHG 50	N71012020	M12	81	110

Cutter - HHCS

Model	Part Number	Bolt Diameter	ft. lbs.	Nm
GHG 4	N97600005	M12	81	110
GHG 6 & GHG 9	N98500077	M16	207	280
GHG 14 - GHG 20	N97600033	M20	332	450
GHG 25 - GHG 50	N97600001			

TROUBLE-SHOOTING GUIDE

Torque Charts (cont'd)

Swivel Support - HHCS

Model	Part Number	Bolt Diameter	ft. lbs.	Nm
GHG 4	—	—	—	—
GHG 6 & GHG 9	N71010025	M10	44	60
GHG 14	N74010016			
GHG 16 - GHG 50	N71012045	M12	81	110

Pin Lock Plate - HHCS

Model	Part Number	Bolt Diameter	ft. lbs.	Nm
GHG 4 - GHG 9	—	—	—	—
GHG 14 - GHG 50	N74012025	M12	96	130

Motor Mounting - HHCS

Model	Part Number	Bolt Diameter	ft. lbs.	Nm
GHG 4	—	—	—	—
GHG 6	N74012030	M12	96	130
GHG 9	N74012050			
GHG 14 - GHG 50	N74012060			

Pinion Gear Set Screw

Model	Part Number	Bolt Diameter	ft. lbs.	Nm
GHG 4	—	—	—	—
GHG 6 & GHG 9	N98500946	M8	6	8
GHG 14 - GHG 50	N98500647	M10	7	10

Medium strength Loctite must be used.

Slewing Ring

Model	Part Number	Bolt Diameter	ft. lbs.	Nm
GHG 4	—	—	—	—
GHG 6	N74012050	M12	96	130
GHG 9	N74012060			
GHG 14	N74016055	M16	258	350
	N74016070			
GHG 16	N74016075	M16	258	350
GHG 20 & GHG 25	N74016075			
	N74016070			
GHG 30 - GHG 50	N74016080	M16	258	350
	N74016090			

Do not use Loctite on slewing ring bolts.

TROUBLE-SHOOTING GUIDE

Torque Charts (cont'd)

Top Bracket

Model	Bolt Diameter	ft. lbs.	Nm
GHG 4 & 6	3/8"	108	146
GHG 9 & GHG 14	3/4"	280	379
GHG 16 & GHG 20	1"	750	1015
GHG 25 - GHG 50	1 1/4"	1500	2030

Swivel Manifold

Model	Part Number	Bolt Diameter	ft. lbs.	Nm
GHG 4	N74010035	M10	52	70
GHG 6	N71010025			
GHG 9	N74010025			
GHG 14	N74012035	M12	96	130
GHG 16 - GHG 50	N74012040			

PINION GEAR INSTALLATION

Insert the key (c7) into the slot on the motor shaft.

Slide the pinion gear (BR) onto the shaft.

Apply a medium-strength Loctite on the set screw (c6) and torque the set screw (c6) using the chart in the fastener torque section of this manual.

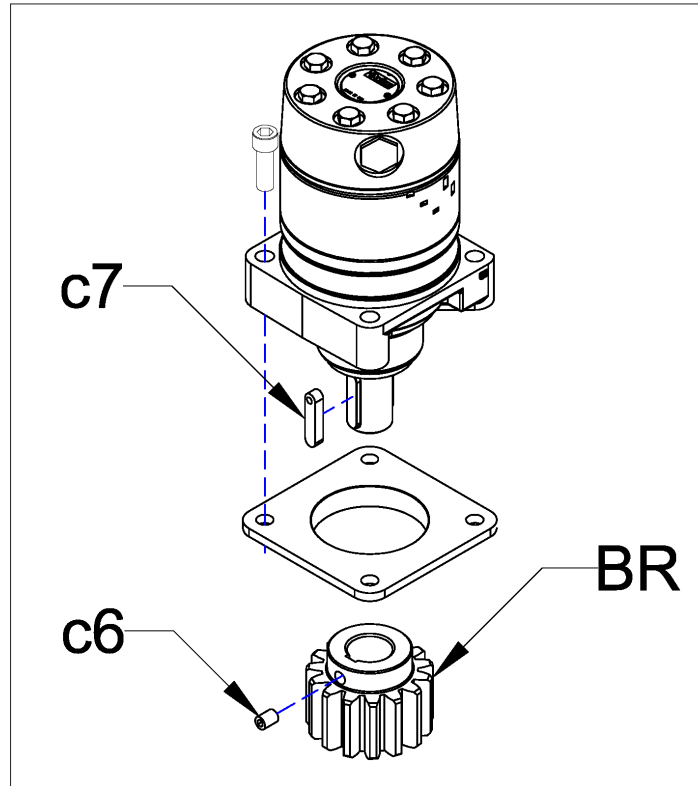

CYLINDER TORQUE SPECIFICATIONS

Rod Nut and Piston Torques

The torques listed below are for the rod nut (c1) and piston (c2) used in the GHG cylinder assembly. When assembling during rebuild, it is also recommended that thread adhesive is used to ensure complete clamping.

	Torque	
	ft. lbs.	Nm
Piston (c2)	1106	1500
Rod Nut (c1)	29.5	40

Apply a small amount of thread adhesive to the set screw (c6) before installing.

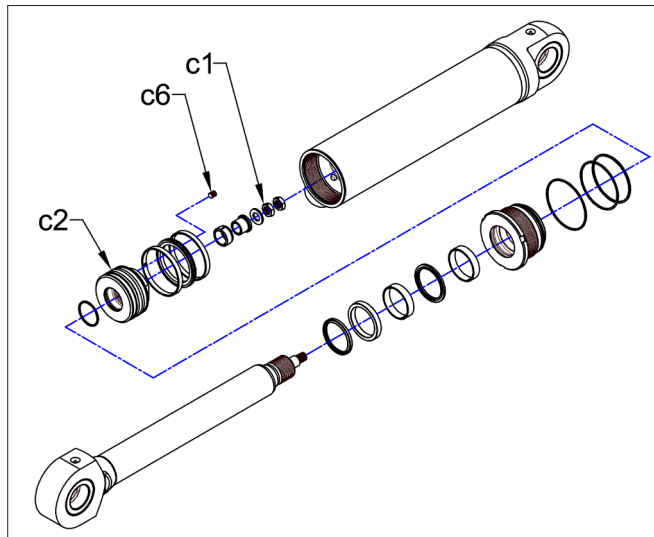

CONVERT FROM DUAL MOTOR TO SINGLE MOTOR

Models GHG 20 - GHG 40

Parts to Remove

AO	N98500849	Hose Assembly
BQ4	N9850201	Hydraulic Motor
BR	N98600640	Pinion Gear
DE	N98601199	Motor Plate
f3	N98500155	Tee
g24	N97600055	Swivel Elbow

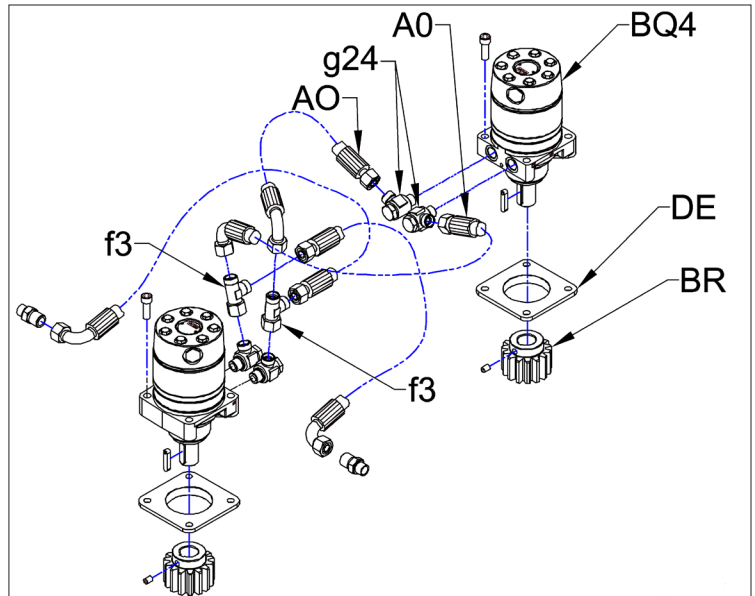

Parts to Add

EC	N98601233	Cover
f1	N97600043	Adaptor Fitting
f4	N97600046	90° Adaptor
f5	N97600044	Adaptor Fitting
fr	N98500241	Flow Valve

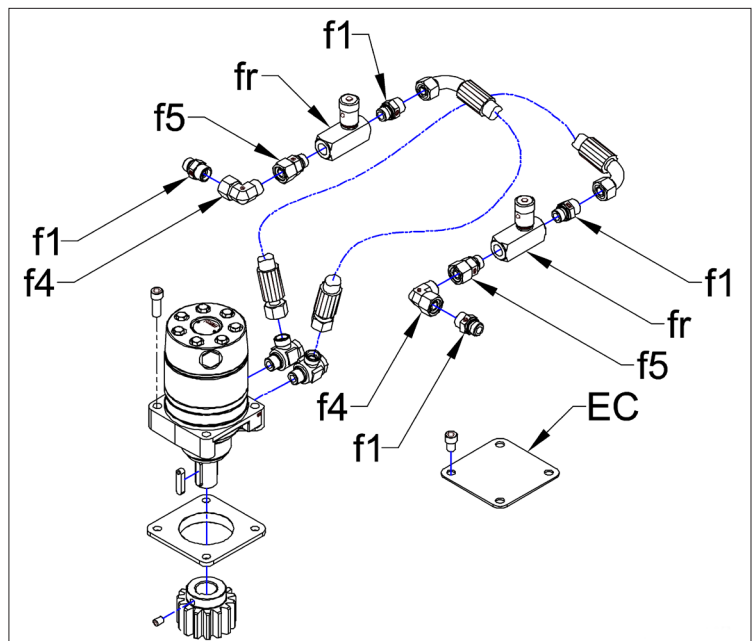

COMPONENT KEYWORDS

GHG 16 Shown

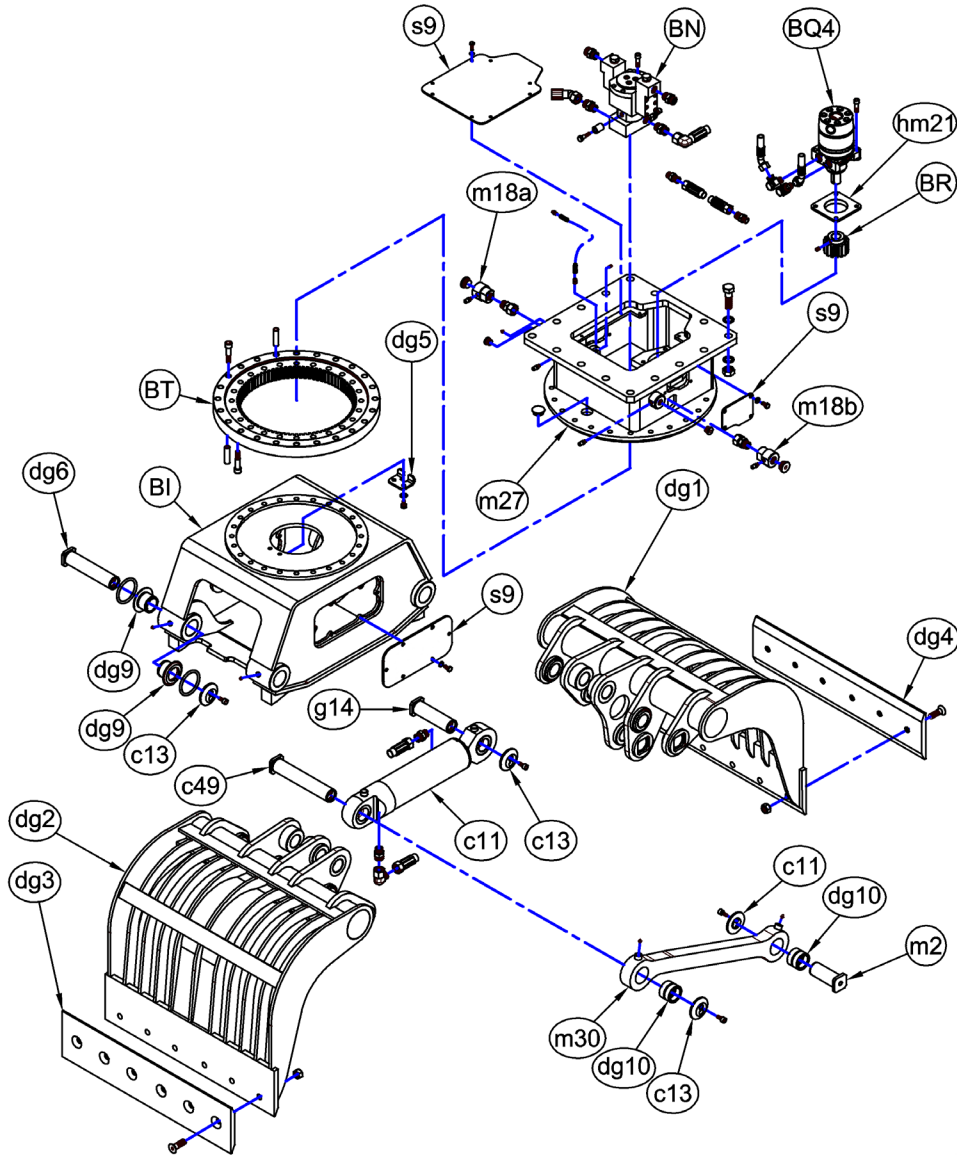

BI	Main Frame
BN	Rotary Joint Assembly
BQ4	Hydraulic Motor
BR	Pinion Gear
BT	Slewing Ring
c11	Cylinder
c13	Pin Lock Plate
c49	Pin (cylinder)
dg1	Drive Arm
dg10	Link Bushing
dg2	Arm
dg3	Cutter (sharp)

dg4	Cutter (blunt)
dg5	Support Bracket
dg6	Arm Pin
dg9	Frame Bushing
g14	Pin (cylinder rod end)
hm21	Motor Mounting Flange
m2	Link Pin
m18a	Joint Fitting (close)
m18b	Joint Fitting (open)
m27	Swivel Flat Top
m30	Link
s9	Cover

WARRANTY

Claim Procedure

Notify the Genesis Service Department of the potential warranty claim prior to making the repair. Digital pictures are very helpful for diagnosing problems and recommending repairs.

Contact the Genesis Service Department before making alterations, changes or repairs to any component that is going to be considered for warranty. Not doing so will void all Genesis warranty consideration.

The Genesis Service Department will issue an authorization number to track the repair costs, outgoing parts, and/or defective parts returning to the factory.

Replacement parts must be ordered using a purchase order number. Shipping is standard ground. Overnight shipping is available by request, and Genesis will not cover the shipping charge.

When the repair is complete, submit an invoice to the Genesis Service Department within 30 days. Include itemized internal labor reporting, parts lists and invoices for outside contractors. Reference the authorization number on all invoices.

When returning parts for warranty consideration, include a copy of any related Genesis paperwork along with any other necessary documentation to ensure proper processing and credit. The Genesis Service Department will provide the necessary forms.

Your account will be credited when the warranty claim is accepted.

Please direct any questions to the Genesis Service Department: 715-395-5252

PARTS ORDER POLICY AND PROCEDURE

Parts Orders Should Include

- Purchase order number
- Model and serial number of attachment
- Part number and quantity needed
- Shipping and billing address
- Method of shipment or required delivery date

Placing Orders

Orders may be placed by phone or e-mail. To e-mail an order, use the form on the following page or your purchase order form. Contact information is located at the front of this manual.

Part Numbers

Part numbers are listed in a separate Parts Manual or, if included, the Parts section of this manual. Contact the Genesis Parts Department with questions regarding part numbers, availability and pricing.

Shipping

All orders will be shipped best way surface unless an alternate shipping method is requested. Shipping charges are not included in the purchase price of parts.

Invoices

All invoices are due upon receipt. Any accounts with invoices open beyond 60 days are subject to review and may be placed on C.O.D. status without further notice.

Returns

Many unused Genesis parts may be returned with proper documentation. Return shipping is the responsibility of the purchaser. Credit will be issued upon return, less a 25% restocking fee. Documentation is required for credit of returned parts. Contact the Genesis Service Department at 715-395-5252 for an RGA (Return Goods Authorization) number and form. An RGA must accompany every return. Items shipped without an RGA may be returned to sender.

Warranty Returns

All parts returned to Genesis for warranty consideration must be returned with a completed RGA (Return Goods Authorization) provided by the Genesis Service Department. The form needs to be completed in its entirety, including any additional information requested by the Service Department. Return shipping is the responsibility of the sender and will be credited upon claim approval. A determination to accept or deny the claim will be made based upon the information available to Genesis. Warranty on purchased parts other than wear components is 6 months. Genesis does not cover labor costs to replace purchased parts replaced under warranty. There is no warranty period on wear parts or components.



PARTS ORDER FORM

Customer: _____ Date: _____
Phone: _____ Contact: _____
Shipping Address: _____ E-mail: _____

Billing Address: _____

Purchase Order: _____ Shipping Method: _____
Model: _____ Serial Number: _____

Quantity	Part Number	Description	Price

E-mail to the Genesis Parts Department: genesisparts@genesisattachments.com
For assistance, call 715-395-5252



GENESIS®

The Promise of Performance.

CONTACT INFORMATION

Genesis Attachments

1000 Genesis Drive
Superior, WI 54880 USA

Toll Free: 888-SHEAR-IT
(888-743-2748)

Phone: 715.395.5252

E-mail:
info@genesisattachments.com

Europe/Africa/Middle East Genesis GmbH

Teramostrasse 23
87700 Memmingen, Germany

Phone: +49 83 31 9 25 98 0

Fax: +49 83 31 9 25 98 80

genesis-europe.com

E-mail:
info@genesis-europe.com

Asia Pacific Representative Office

24 Upper Serangoon View #12-28
Singapore 534205

Phone: +65 9673 9730

E-mail:
tchoo@genesisattachments.com

Central America & Colombia

Cra 13A #89-38 / Ofi 613
Bogota, Colombia

Phone: +57 1 610 8160 / 795 8747

E-mail:
contact@themsagroup.com

View and download all manuals: genesisattachments.com/manuals
Patents: genesisattachments.com/products/patents