



Rail Breaker (GRB 30)

SAFETY & OPERATOR'S MANUAL



The GRB 30 processes 136 lb. and smaller low chrome rail.

CONTACT INFORMATION

Genesis Attachments

1000 Genesis Drive
Superior, WI 54880 USA

Toll Free: 888-Attachment-IT
(888-743-2748)

Phone: 715.395.5252

E-mail:
info@genesisattachments.com

Europe/Africa/Middle East Genesis GmbH

Teramostrasse 23
87700 Memmingen, Germany

Phone: +49 83 31 9 25 98 0
Fax: +49 83 31 9 25 98 80
genesis-europe.com

E-mail:
info@genesis-europe.com

Asia Pacific Representative Office

24 Upper Serangoon View #12-28
Singapore 534205

Phone: +65 9673 9730

E-mail:
tchoo@genesisattachments.com

Central America & Colombia

Cra 13A #89-38 / Ofi 613
Bogota, Colombia

Phone: +57 1 610 8160 / 795 8747

E-mail:
contact@themsagroup.com

View and download all manuals: genesisattachments.com/manuals
Patents: genesisattachments.com/products/patents

PREFACE

To ensure years of safe, dependable service, only trained and authorized persons should operate and service your Genesis attachment. It is the responsibility of the product's owner to ensure the operator is trained in the safe operation of the product and has available this manual for review. It is the responsibility of the operator and maintenance personnel to read, fully understand and follow all operational and safety-related instructions in this manual. The attachment should not be operated until you have read and fully understand these instructions. Always use good safety practices to protect yourself and those around you.

Important

This operator's manual must accompany the attachment at all times and be readily available to the operator.

Manual Replacement

Should this manual become damaged or lost or if additional copies are required, immediately contact any authorized Genesis dealer or the Genesis Service Department at 888-743-2748 or 715-395-5252 for a replacement.

Registration Form

The Warranty Registration Form must be filled out by the dealer or customer and returned to Genesis indicating the date the attachment went into service.

Possible Variations

Genesis cannot anticipate every possible circumstance that might involve a potential hazard as the owner's requirements and equipment may vary. Therefore, the warnings in this publication and on the product may not be all-inclusive, and you must satisfy yourself that the procedure, application, work method or operating technique is safe for you and others before operating.

Public Notice

Genesis reserves the right to make changes and improvements to its products and technical literature at any time without public notice or obligation. Genesis also reserves the right to discontinue manufacturing any product at its discretion at any time.

Warranty

All work or repairs to be considered for warranty reimbursement must be pre-authorized by the Genesis Service Department. Any alterations, modifications or repairs performed before authorization by the Genesis Service Department will render all warranty reimbursement consideration null and void without exception. See page 47 for Warranty Claim Procedures.

Improper operation or improperly performed maintenance may render any warranty null and void.

TABLE OF CONTENTS

CONTACT INFORMATION	2
PREFACE	3
Important	3
Manual Replacement	3
Registration Form	3
Possible Variations	3
Public Notice	3
Warranty	3
SAFETY STATEMENTS	7
OPERATIONAL SAFETY	8
Read Manual Before Operating or Maintaining the Attachment	8
Personal Protection	8
Know Your Equipment	8
Before Operating	8
Check the Equipment	9
Stability	9
Know the Work Area	10
Starting Procedure	10
Place the Load Safely	10
Safely Operate Equipment	11
Transporting the Attachment	12
Equipment Condition	12
Working Overhead	12
Power Lines	12
Use Care with Hydraulic Fluid Pressure	13
Prioritized Oil Flow	14
Emergency Situations	14
Unsafe Conditions	14
Crystalline Silica Dust	14
Prop. 65 Warning for California Residents	14
Process Material Safely	15
Lift the Load Safely	15
Place the Load Safely	15
ATTACHMENT NOMENCLATURE	16
ATTACHMENT INSTALLATION	18
Dual-Pump Flow	18
Installation Procedure	18
CASE DRAIN	20
ROTATOR INSTALLATION	21
Rotation Circuit - Gear Pump Type	22
Rotation Circuit - Auxiliary Valve on Machine	23
Foot Switch Installation	24
HYDRAULIC START-UP	25
Start-up Procedure	25

TABLE OF CONTENTS

GENERAL OPERATION INSTRUCTIONS	26
Start-up.....	26
Efficient and Productive Operation.....	26
MAINTENANCE SAFETY	27
MAINTENANCE SCHEDULE	29
Scheduled Maintenance.....	29
Four-Hour Checklist.....	30
Eight-Hour Checklist.....	30
LUBRICATION POINTS	31
BOLT TORQUE SPECS	32
BLADE MAINTENANCE	33
AUTOGUIDE	34
AutoGuide Adjustment Procedure.....	34
Wear.....	34
GUIDE BLADES	35
Rotation.....	35
Shims.....	35
Blade Gap.....	36
Blade Gap Measuring Procedure.....	36
Adjustment Plates.....	36
CUTTING BLADES	37
GENERAL WELDING GUIDELINES	38
Welding Ground Clamp.....	38
Welding Rules.....	38
BUILD-UP	39
Areas to be built up.....	39
Grind material flush.....	39
Straight edge.....	39
HARD-SURFACING	40
HARD-SURFACING PATTERNS	41
Grain.....	41
HYDRAULIC/ROTATION MAINTENANCE	42
Hydraulic Requirements.....	42
Rotation Valve Input.....	42
SLEWING RING MAINTENANCE	43
ROTATION MOTION CONTROL VALVE ADJUSTMENT	44
Adjusting the Rotation Motion Control Valve.....	44
TROUBLE-SHOOTING GUIDE	45
WARRANTY	47
Claim Procedure.....	47
Blade Warranty.....	47

TABLE OF CONTENTS

- PARTS ORDER POLICY AND PROCEDURE**..... **48**
- Parts Orders Should Include..... 48
- Placing Orders..... 48
- Part Numbers..... 48
- Shipping..... 48
- Invoices..... 48
- Returns..... 48
- Warranty Returns..... 48
- PARTS ORDER FORM**..... **49**
- CONTACT INFORMATION**..... **50**

NOTICE For bolt torque specs, see the Genesis Fastener Manual.
genesisattachments.com/manuals

SAFETY STATEMENTS



This symbol by itself or used with a safety signal word throughout this manual is used to call attention to instructions involving your personal safety or the safety of others. Failure to follow these instructions can result in injury or death.



This statement is used where serious injury or death will result if the instructions are not followed properly.



This statement is used where serious injury or death could result if the instructions are not followed properly.



This statement is used where minor or moderate injury could result if the instructions are not followed properly.

NOTICE

This statement is used where property damage could result if the instructions are not followed properly.

OPERATIONAL SAFETY

Read Manual Before Operating or Maintaining the Attachment



Read this manual before attempting to operate the attachment. This operator's manual should be regarded as part of the attachment. For proper installation, operation and maintenance of the attachment, operators and maintenance personnel must read this manual.



WARNING

Serious injury or death could result if appropriate protective clothing and safety devices are not used.

Personal Protection

Use protective clothing and safety devices appropriate for the working conditions. These may include but are not limited to:

- ✓ Hard hat
- ✓ Safety glasses, goggles or face shield
- ✓ Hearing protection
- ✓ Safety shoes
- ✓ Heavy gloves
- ✓ Reflective clothing
- ✓ Respirator or filter mask



Safety matters

Know Your Equipment



Know your attachment's capabilities, dimensions and functions before operating. Inspect your attachment before operating and never operate an attachment that is not in proper working order. Remove and replace any damaged or worn parts.

Before Operating

- ✓ Warn all others in the area that you are about to start operation.
- ✓ Perform the Check the Equipment steps outlined in this manual.
- ✓ Check underneath and around the machine. Make sure all personnel and equipment are clear from the area of operation and equipment movement. Check clearances in all directions, including overhead.
- ✓ Be properly seated in the operator's seat.
- ✓ Do not attempt to operate until you have read and fully understand this manual and the OEM manual for the carrier.

OPERATIONAL SAFETY

Check the Equipment

Before use, check the equipment to ensure it is in good operating condition.

Check the following:

- ✓ Grease fittings. Pump grease at all fitting locations, see page 31.
- ✓ Hydraulic fluid level. Add hydraulic fluid as required.
- ✓ Hydraulic hoses and hose connections for wear or leaks. Repair or replace any damaged hoses or connections.
- ✓ All control levers for proper operation.
- ✓ Rotation bearing. Visually check for loose or damaged bolts. If repair is required, refer to qualified personnel.
- ✓ Grease rotation bearing and pinion gear.
- ✓ Check for loose or missing pin retaining bolts.
- ✓ Check cylinders for dents (barrel) or dings (rod).



**GOOD
CONDITION**



WARNING

Serious injury or death could result if warnings or instructions regarding carrier stability and the work area are not followed properly.

Stability

Your Genesis attachment is sized for carrier stability. However, improper operation, faulty maintenance or unauthorized modifications may cause instability.

- ✓ Know the working ranges and capacities of the carrier to avoid tipping.
- ✓ Use the recommended carrier counter weight.

The following conditions affect stability:

- Ground conditions
- Grade
- Weight of attachment
- Contents of attachment
- Operator judgement



For greater stability, knuckle the attachment to bring the load closer to the center of rotation (center of gravity) while lifting. Use extra caution during reaching to avoid tipping.

OPERATIONAL SAFETY

Know the Work Area

Check clearances in the work area. Keep all bystanders at a safe distance. Do not work under obstacles. Always check your location for overhead and buried power lines or other utilities before operation.

Check ground conditions. Avoid unstable or slippery areas. Position the carrier on firm level ground. If level ground is not possible, position the carrier to use the attachment to the front or back of the carrier. Avoid working over the side of the carrier.

To reduce the risk of tipping and slipping, never park on a grade exceeding 10% (one-foot rise over the span of a ten-foot run).

Starting Procedure

Before operating, walk completely around the equipment to make certain no one is under it, on it or close to it. Keep all bystanders at least 75 feet away from the area of operation and equipment movement. Let all other workers and bystanders know you are preparing to start. DO NOT operate until everyone is clear.

Always be properly seated in the operator's seat before operating any carrier controls.

To start:

- ✓ Make sure all controls are in the center (neutral) position.
- ✓ Be properly seated.
- ✓ Slowly operate all functions to check for proper operation and to bleed air from the hydraulic system.

To shut down:

- ✓ Return your Genesis attachment to a rest position on the ground.
- ✓ Shut off the carrier engine.
- ✓ Work controls in all directions to relieve hydraulic pressure, per excavator manufacturer's instructions.



WARNING

Serious injury or death could result if warnings or instructions regarding safe operation are not followed properly.

Place the Load Safely

Do not move the attachment, or anything held in the jaws, over people, equipment or buildings. Do not throw or drop the contents. Operate the controls smoothly and gradually.

OPERATIONAL SAFETY

Safely Operate Equipment

Do not operate equipment until you are trained by a qualified operator in its use and capabilities.

See your carrier's manual for these instructions.

- ✓ Operate only from the operator's seat. Check the seat belt daily and replace if frayed or damaged.
- ✓ Do not operate this or any other equipment under the influence of drugs or alcohol. If you are taking prescription medication or over-the-counter drugs ask your medical provider whether you can safely operate equipment.
- ✓ Never leave equipment unattended with the engine running or with the attachment in a raised position. Apply the brakes before exiting the equipment.
- ✓ Do not exceed the lifting capacity of your carrier.
- ✓ Avoid conditions that can lead to tipping. The carrier can tip when operated on hills, ridges, banks and slopes. Avoid operating across a slope which could cause the carrier to overturn.
- ✓ Reduce speed when driving over rough terrain, on a slope, or when turning to avoid overturning the carrier.
- ✓ Never use the attachment as a work platform or personnel carrier.
- ✓ Keep all step plates, grab bars, pedals and controls free of dirt, grease, debris and oil.
- ✓ Never allow anyone to be around the equipment when it is operating.
- ✓ Do not operate poorly maintained or otherwise faulty equipment. Inform the proper authority and DO NOT resume operation until the problem has been fixed.
- ✓ Do not alter or remove any safety features.
- ✓ Know your work site safety rules as well as traffic rules and flow. When in doubt on any safety issue, contact your supervisor or safety coordinator for an explanation.
- ✓ A heavy load can cause equipment instability. Use extreme care during travel. Slow down on turns and watch out for bumps. The equipment may need additional counter-weights to counterbalance the weight of the attachment.



OPERATIONAL SAFETY

Transporting the Attachment

- ✓ Travel only with the attachment in a safe transport position to prevent uncontrolled movement. Drive slowly over rough ground and on slopes.
- ✓ When driving on public roads use safety lights, reflectors, Slow Moving Vehicle signs, etc., to prevent accidents. Check local government regulations that may affect you.
- ✓ Do not drive close to ditches, excavations, etc., as cave-in could result.
- ✓ Do not smoke when refueling the prime mover. Allow room in the fuel tank for expansion. Wipe up any spilled fuel. Secure cap tightly when done.

Equipment Condition

Never operate poorly maintained equipment. When maintenance is required, repair or replace parts immediately.



WARNING

Serious injury or death could result if warnings or instructions regarding working overhead are not followed properly.

Working Overhead

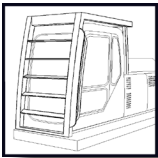

Avoid handling material overhead whenever possible. Safety glass and wire mesh cab guarding must be installed to protect the operator from flying debris that may be created during handling. Falling Object Protection Structures, or FOPS, are necessary for any application where material is to be handled overhead.



DANGER

Serious injury or death will result if warnings or instructions regarding power lines are not followed properly.

Power Lines

Do not operate the machine near energized power lines. All local, state/provincial and federal regulations must be met before approaching power lines, overhead or underground cables, or power sources of any kind with any part of the carrier or attachment. Always contact the appropriate utility when operating near power lines. The lines should be moved, insulated, disconnected or de-energized and grounded before operating in the area.



Current in high voltage lines may arc some distance from the wire to a nearby ground. Keep all parts of the machine at least 50 feet (16m) away from power lines.

OPERATIONAL SAFETY



WARNING

Serious injury or death could result if warnings or instructions regarding hydraulic fluid pressure are not followed properly.

Use Care with Hydraulic Fluid Pressure

Hydraulic fluid under pressure can penetrate the skin and cause serious injury or death. Hydraulic leaks under pressure may not be visible.

- ✓ Keep unprotected body parts, such as face, eyes and arms as far away as possible from a suspected leak. Flesh injected with hydraulic fluid may develop gangrene or other permanent injuries.
- ✓ If injured by injected fluid see a doctor immediately.
- ✓ Wear safety glasses and protective clothing and use a piece of cardboard or wood when searching for hydraulic leaks.

Do Not Use Your Hands!
See illustration below.

- ✓ Hydraulic oil becomes hot during operation. Do not let hydraulic oil or components contact skin, as it could cause severe burns. Allow hydraulic components to cool before working on them. Use appropriate protective clothing and safety equipment. If burned, seek immediate medical attention.

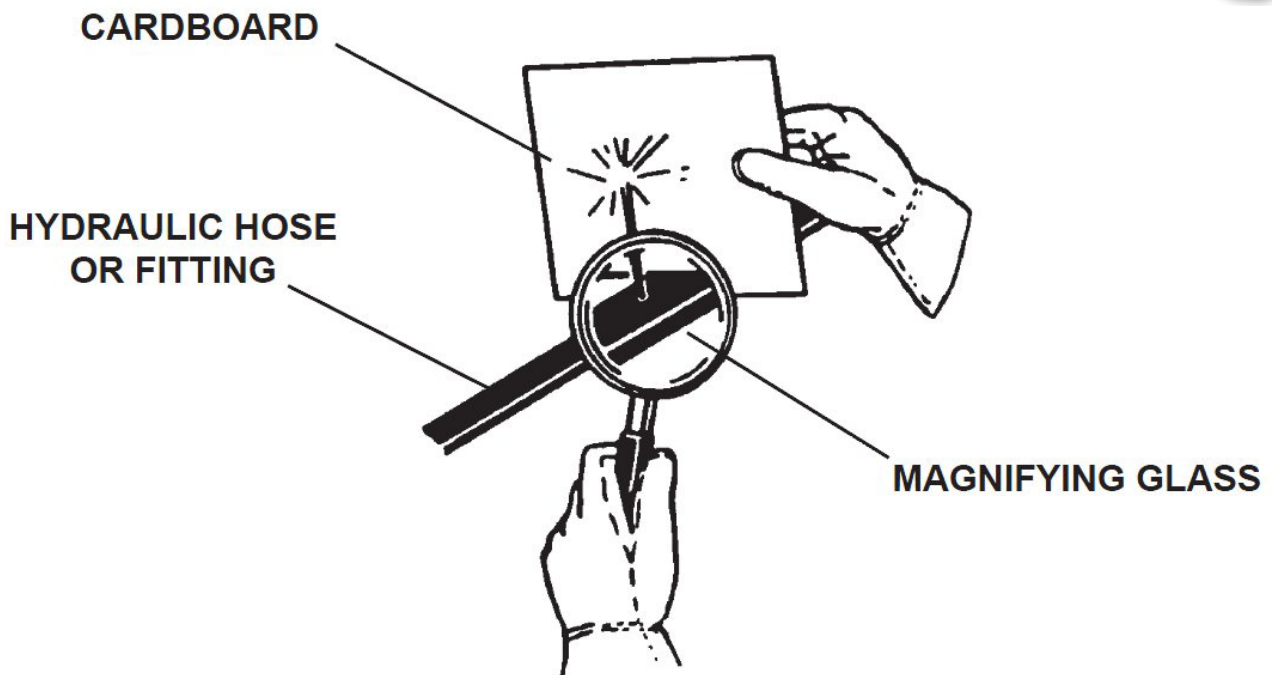

OPERATIONAL SAFETY

Prioritized Oil Flow

Equipment operators must ensure there is prioritized oil flow to the main valves in overhead operations or high reach conditions.

Emergency Situations

Always be prepared for emergencies. Make sure a fire extinguisher is available. Be familiar with its operation. Make sure to inspect and service the fire extinguisher regularly. Make sure a first aid kit is readily available.



Unsafe Conditions

Do not operate if an unsafe condition exists. Stop operation immediately, shut down the machine and report the unsafe condition to the proper authority. Equipment operation and maintenance practices directly affect your safety and the safety of those around you. Always use common sense while operating and be alert to unsafe conditions.

Crystalline Silica Dust

It is recommended to use dust suppression, dust collection and if necessary, personal protective equipment during the operation of any attachment that may cause high levels of dust.



Exposure to respirable crystalline silica dust along with other hazardous dusts may cause serious or fatal respiratory disease.

IMPORTANT: Concrete and masonry products contain silica sand. Quartz, which is a form of silica and the most common mineral in the Earth's crust, is associated with many types of rock.

Some activities that may have silica dust present in the air include demolition, sweeping, loading, sawing, hammering, drilling or planing of rock, concrete or masonry.

It is recommended to use dust suppression (such as water) or dust collection (such as a vacuum) along with personal protective equipment if necessary during the operation of any attachment that may cause high levels of silica dust.



Prop. 65 Warning for California Residents



This product may contain chemicals known to the State of California to cause cancer, birth defects, or other reproductive harm. For more information visit: P65Warnings.ca.gov

OPERATIONAL SAFETY



WARNING

Using your Genesis attachment in unauthorized applications may create an unsafe situation and will void the warranty.

Process Material Safely

- This tool was designed to break rail. Processing rail is dangerous because rail breaks and does not cut. Extreme caution must be used to process rail safely. Rail should be processed with the back/bottom of the rail breaker facing the carrier. Rail should be processed as far out from the operator as possible and on the ground. Operating adjustments must be made to reduce flying debris. Cab guarding is highly recommended.
- Do not operate any functions of the carrier while cutting or crushing with your Genesis attachment, including boom and drive functions.
- Do not pull down structures with your Genesis attachment. Doing so may cause falling debris or material may break free and exceed the capacities of the carrier, causing a tipping hazard.
- The rotator should only be used for positioning your Genesis attachment. Do not use the rotator to pry or break material.

Lift the Load Safely

- The hydraulic system has been preset and tested by your dealer. Do not alter hydraulic settings without consulting an authorized Genesis dealer or the Genesis Service Department. Doing so will void the warranty and may cause structural damage, accidents or tipping.
- Make sure the load is held securely in the jaws. Do not move a loaded attachment if the load is loose or dangling. Make sure the load is pinched between the jaws – never cradle a load.
- For greater stability, knuckle the attachment to bring the load closer to the center of rotation (center of gravity) while lifting. Use extra caution during reaching to avoid tipping.

Place the Load Safely

- Do not move the attachment, or anything held in the jaws, over people, equipment or buildings. Place the load gently. Do not throw or drop the contents.
- Operate the controls smoothly and gradually. Jerky controls are hazardous and may cause damage to the carrier.
- Avoid fire hazards. Keep the area clean. Remove all flammable materials from the area during any welding or heating process. Have a fire extinguisher nearby and know how to use it.
- Never substitute pins or bolts. Use factory supplied pins. Replace all bolts with the same size and grade. Failure to do so may cause serious injury or death.
- Use your Genesis attachment only as directed in this manual. Do not use the attachment to lift and move other objects. Doing so may cause instability and tipping.

ATTACHMENT NOMENCLATURE

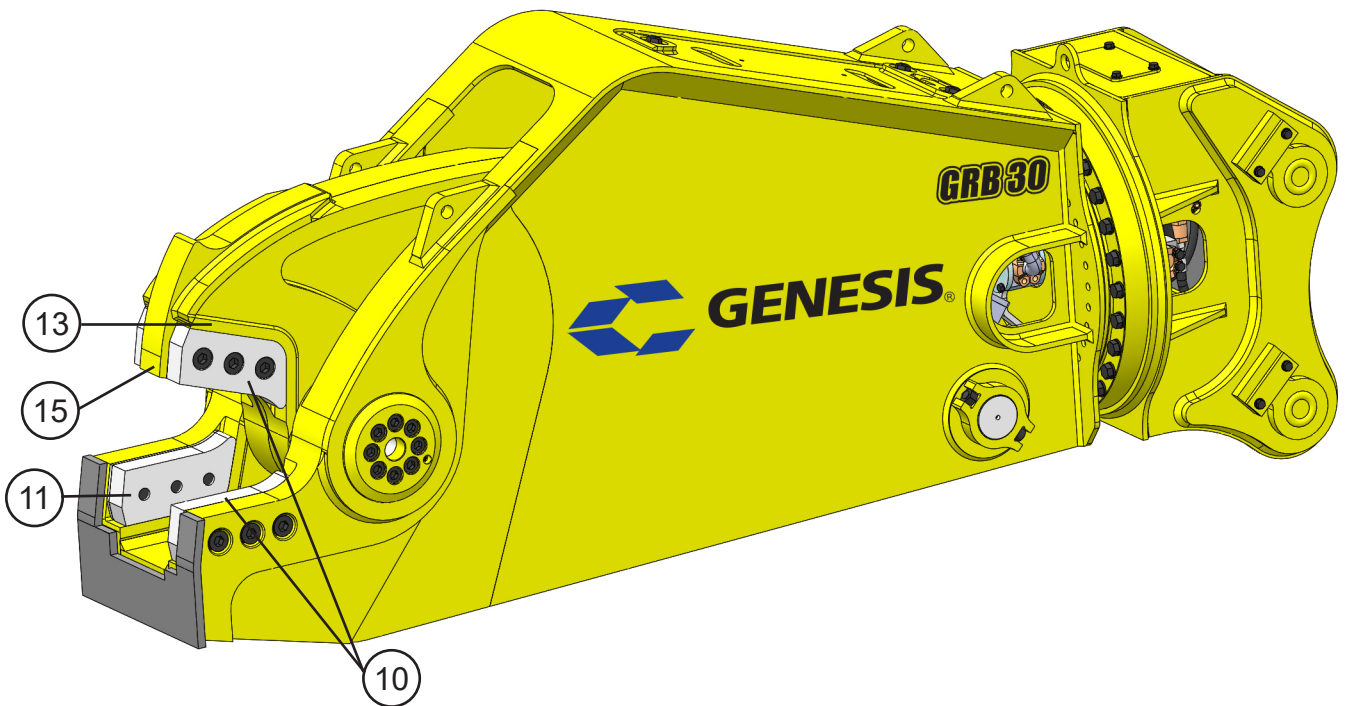
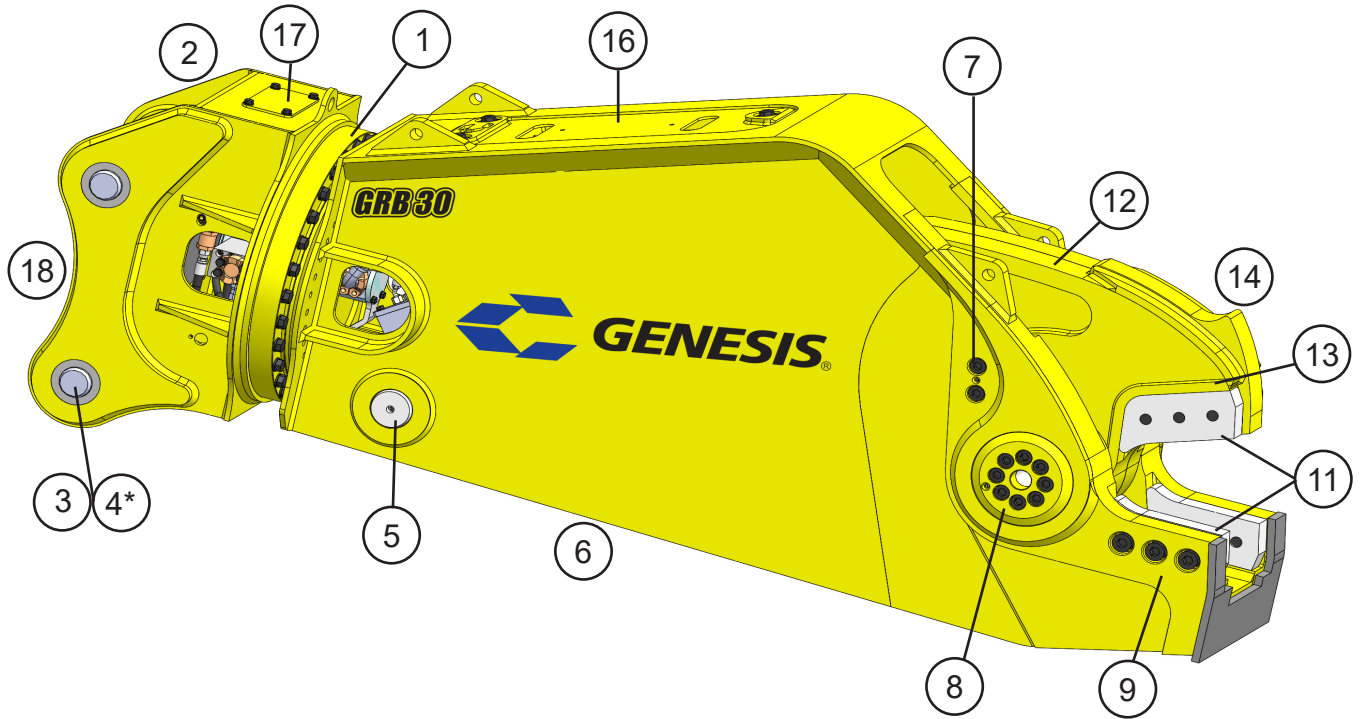

ATTACHMENT NOMENCLATURE

1	Slewing Ring	Connects the attachment head to the attachment stick or body. Not used on straight attachments.
2	Sub-Head	Houses and protects the hydraulic components used for 360° rotation
3	Stick-Pin Connection	Tool connection to excavator 3rd member
4	Boom Pivot Connection	Tool connection to excavator 2nd member (*not shown)
5	Rear Cylinder Pin	Main cylinder connection to attachment stick
6	Stick or Body	Houses and protects the main hydraulic cylinder
7	AutoGuide or Puck	See the Genesis Fastener Manual for torque values.
8	Pivot Group	Includes the pivot shaft, bearings and end caps
9	Lower Jaw	Lower part of jaw housing blades
10	Guide Blades	Blades mounted on the left side of the attachment, designed to eliminate wear on the guide side of the jaw. These are not the main cutting blades.
11	Blades	Upper and lower cutting blades
12	Upper Jaw	Moving jaw connected to the cylinder
13	Protection Strips	Raised areas of parent material along the blade pockets on upper and lower jaws should be flush to 0.010" below the blade faces.
14	Rhino Horn	Weld-on upper jaw protection, 3 piece
15	Tang	Parent material underneath and between the piercing blades
16	Access Cover	Access to hydraulic cylinder
17	Access Cover	Access to hydraulic motor and rotation flow controls
18	Attachment Head Lugs	Attachment serial number required for replacement parts

ATTACHMENT INSTALLATION

Preparation of the excavator prior to attachment delivery will make installation safer and easier. Contact Genesis or your Genesis dealer for assistance.

Dual-Pump Flow

Typically, an excavator has two hydraulic pumps supplying oil to the main valves of the excavator. The main valves usually are separated into two halves. Tying two circuits from opposite sides of the valve is called summing – basically achieving dual-pump flow to operate one system. This is the preferred method of achieving maximum speed to a attachment. This may also be achieved by interchanging the stick and bucket circuits.

Usually a bucket circuit is single-pump flow and a stick circuit is dual-pump flow. At times, adding an auxiliary circuit spool to the stick circuit helps reduce back-pressure in the system and speed up jaw open and close.

In certain cases, the bucket and auxiliary circuits can be summated to achieve dual-pump flow, depending on whether the bucket and auxiliary are on separate sides of the main valve and whether the auxiliary circuit can be proportionally controlled by teeing into the bucket pilot control circuit. The auxiliary circuit must also be capable of proportionally controlling pump initiation on the auxiliary side of the circuit. On many excavators, the auxiliary circuit is controlled by percentage of flow set in the computer. This may not control the speed that the pump's compensator strokes up, but turns the circuit instantly on or off. Because attachments take all the flow the pumps can give them, the computer signals the pump to instantly turn on or off, instead of gradually ramping up or down, which can cause sharp, damaging spikes in the hydraulic circuit.

Installation Procedure

Note: The attachment is usually shipped in an upright position. Extreme care must be used when inverting the attachment for installation.

Remove bucket or other stick attachments, following the excavator OEM's removal and safety instructions.



Removing any connecting pin may be hazardous. To remove a connecting pin, position the attachment on the ground and properly support.



Particles may fly when a pin is struck. Use a drift pin or mallet when striking pins. Keep all personnel at a safe distance.

ATTACHMENT INSTALLATION



WARNING

Be sure hydraulic pressure is relieved before disconnecting hydraulic fittings. Remove necessary fittings SLOWLY.

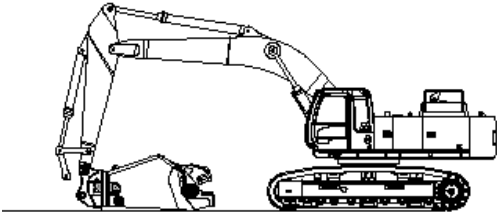

1. Position the attachment upside down on flat, solid ground. NOTE: Blocking may be required to raise the mounting bracket into proper position.

2. Track the excavator to the attachment with the jaws facing the operator. Lift the excavator stick over the attachment, carefully positioning the stick tip connection with the attachment mounting main pivot bore. Pin the excavator stick to the attachment.

3. Slowly raise the boom to lift the attachment, allowing the attachment cylinder pivot connection to come within range of the excavator cylinder stroke.

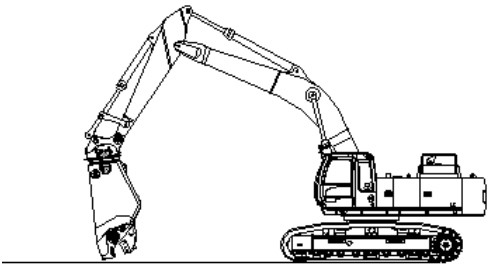

4. Extend the excavator cylinder until the power link bore lines up with the attachment cylinder pivot connection. Pin excavator cylinder to the attachment.

5. Crowd and extend the attachment, checking closely to make sure there is no interference between the attachment bracket and hard lines. Also check for interference between the cylinder and boom/stick.

6. Install excavator hydraulic hoses, supply and return, from the stick tip to the attachment manifold blocks.

7. The stick and bucket circuits are oriented as to rod and bore sides of their respective cylinders. When you connect a circuit to the attachment, take care to connect rod-to-rod and bore-to-bore. When these are reversed, extra pressure is needed to open the jaw, which pulls down the engine, destrokes the pumps, increases jaw cycle time, creates high oil temperatures and burns more fuel.

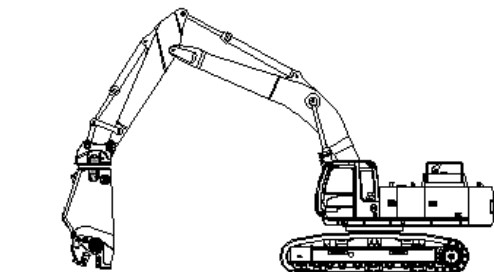

Note: Genesis' standard pin material is Induction Hardened Chrome (IHC), which is to be used for all direct pin 2nd and 3rd member mounting. To avoid risk of pin failure when using a pin grabbing coupler, the standard IHC pins must be replaced with a heat-treated pin material from Genesis.

CASE DRAIN

The GRB 30 rotation system requires an additional case drain line to the tank. The case drain line (in red) can be relocated to either side of the head as required by the excavator pumbing.

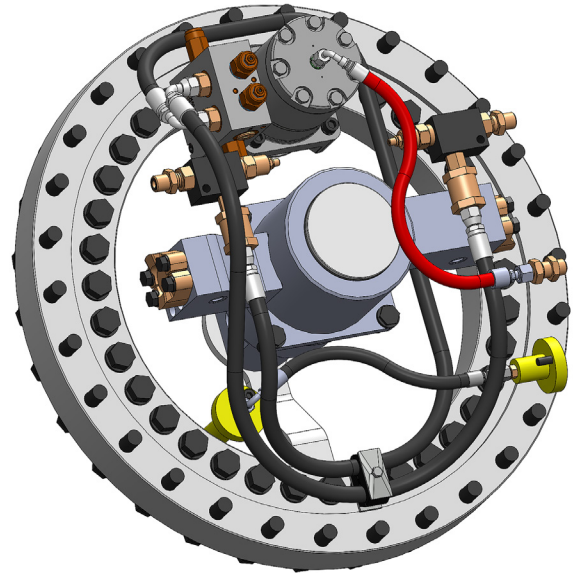

ROTATOR INSTALLATION

The rotator requires a 1/2" minimum case-drain line with a minimum working pressure rating of 250 PSI. **Run the case-drain line from the rotation head of the shear to a dedicated filter on the excavator, plumbed directly into the main section of the hydraulic tank. Do not plumb to the return side of the tank.**

The maximum case-drain pressure measured at the motor while attempting to rotate the shear stalled on the ground is 40 PSI for an axial piston motor. Gerotor type motors may or may not require a case drain. If 3 O-ring face seal bulkheads are present on your sub-head, a case drain is required. If you are unsure of your motor type or if a case drain is required, contact the Genesis Parts or Service Departments with the serial number of your shear. Case-drain pressures will rise during cold weather operation.

Use the correct fittings. Secure the case-drain line to the excavator stick.

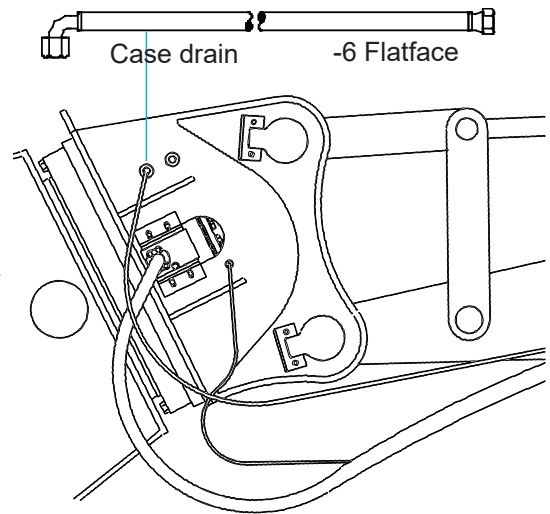

NOTICE

Do not plumb the case-drain into the main return system or into any other existing case drain or return circuit. Plumb only to the hydraulic tank.

ROTATOR INSTALLATION

Rotation Circuit - Gear Pump Type

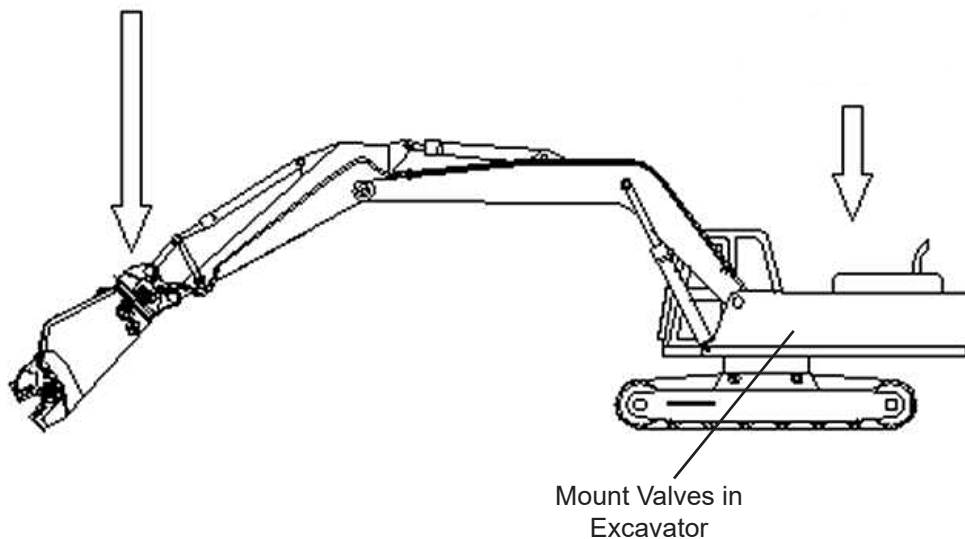
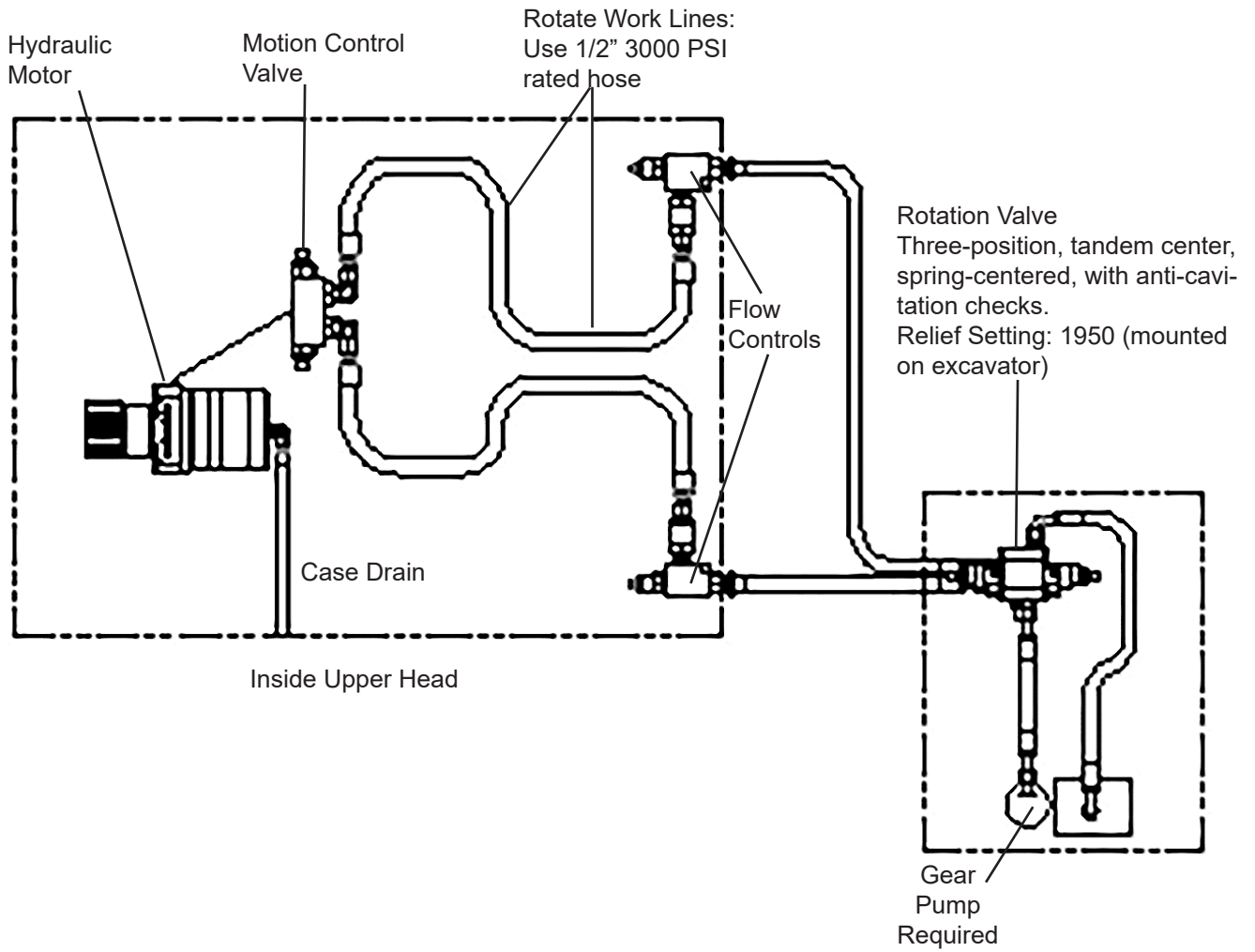

ROTATOR INSTALLATION

Rotation Circuit - Auxiliary Valve on Machine

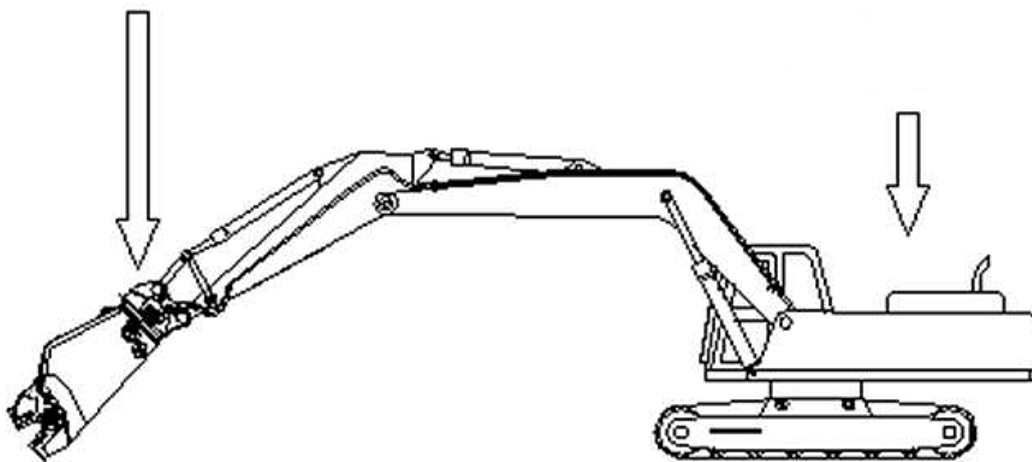
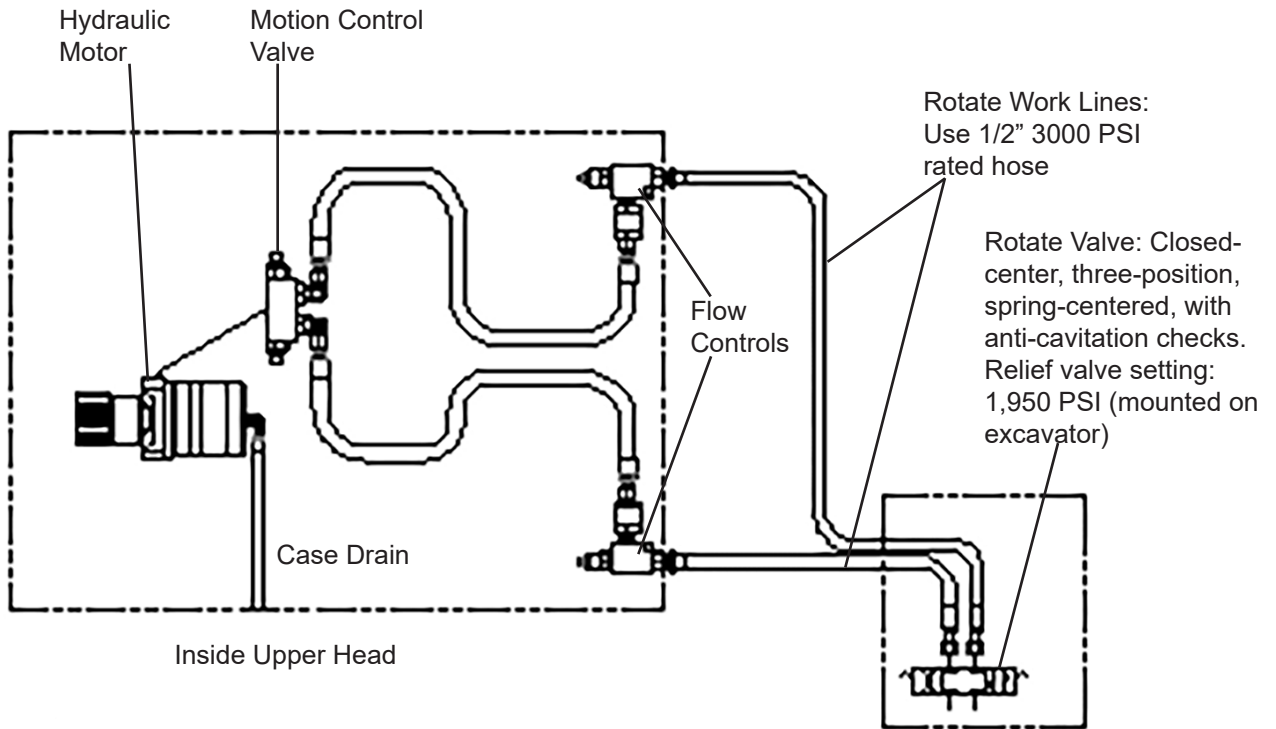

ROTATOR INSTALLATION

Foot Switch Installation

Install the foot switch in the excavator and connect with electrical harness.

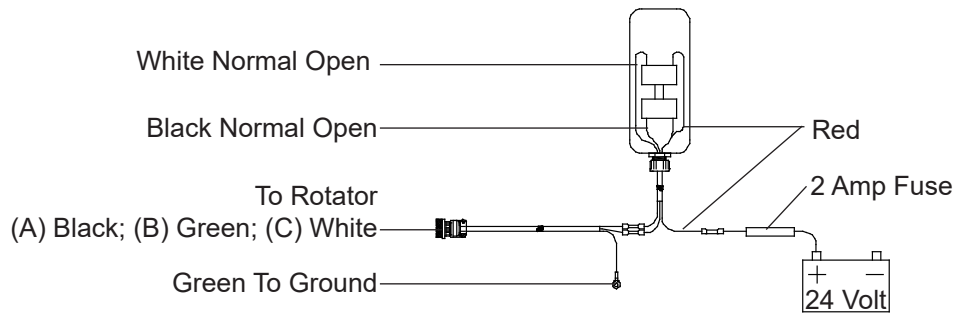

The rotator requires an additional hydraulic circuit. One of the several available options has been supplied with the attachment. These diagrams show the installation of the additional circuit. Refer to the Hydraulic/Rotation Maintenance section of this manual for valve descriptions, functions and settings.

HYDRAULIC START-UP

The Genesis Rail Breaker is designed to operate under full excavator pressure or up to 5500 PSI. Due to these high pressures, it is important that air is bled from the attachment cylinder after installation. Failure to follow these procedures could result in cylinder seal damage and/or excavator hydraulic system damage.

Start-up Procedure

- ✓ Check the excavator hydraulic tank for proper fluid level.
- ✓ Excavator oil should be warmed up before hooking up attachment lines in cold weather. If oil is cold, air from the cylinder will be pushed into the oil tank, causing oil to foam. This problem takes hours to correct, and it may cause pump cavitation.
- ✓ Follow the OEM procedures for starting and warming the excavator hydraulic system. Do not operate the attachment circuit during the warm-up period.
- ✓ After the excavator has reached normal operating temperature, set the engine to idle speed.
- ✓ Attachment must be vertical. Do not allow the tank to run low - have someone watch the oil gauge.
- ✓ Slowly fill the bore end of the attachment cylinder to partially close the jaws.

NOTICE

Do not fully extend or retract attachment cylinder with the first cycles.

- ✓ Slowly fill the rod end of the attachment cylinder to open the jaws. Use partial strokes extending and retracting, slowly working to full strokes.
- ✓ Stop and check the excavator hydraulic fluid level again to be sure there is still sufficient fluid. Service as required. Note: hydraulic fluid level should be checked with the attachment jaws open (cylinder retracted).
- ✓ Cycle the attachment jaws five or six strokes before increasing to full operating pressure.

GENERAL OPERATION INSTRUCTIONS

The GRB 30 is designed to process 136 lb. and smaller low chrome rail.

Follow all rules and procedures outlined in the Operational Safety section of this manual.

Use the attachment only as intended, in approved applications, as set forth in this manual.

Do not allow attachment, exposed cylinder rod or hoses to come into contact with any obstacles, buildings or the excavator.

The attachment is not intended to crush or break objects or structures by swinging or dropping the attachment.

Start-up

Stage the rail into rows in a heads-up position as much as possible. This allows subsequent cuts to be made with less positioning of the tool. Avoid dragging long pieces of rail as much as possible. This causes excessive pressure on the rotation hydraulics by back-driving the motor, gear box and valve, which will shorten the life of these components. Do not utilize the hydraulic rotation to turn pieces of rail in mid-air.

Efficient and Productive Operation

Operators should become accustomed to performing work in the most proficient manner possible.

When cutting, keep the surfaces of the attachment chin plate and upper jaw out of the dirt as much as possible. Dirt is abrasive and needlessly increases build-up and hard-surfacing time and intervals.

It also helps to give yourself enough room to keep out of the way of other personnel and machines.

Material processing areas should be as close as safely possible to the location for loading materials for transportation. Less time spent processing, loading and transporting materials greatly affects operational costs and productivity and dramatically reduces man hours, fuel costs and wear on equipment.

Operators should develop the habit of assessing materials to be processed and visualizing a starting and finishing point to use the fewest cuts possible. Excessive moving, positioning and handling cost time and money. Bringing the jaws to full open, when only partial jaw open is needed for a cut, wastes time and fuel, slows other excavator functions as well as causes needless wear to hydraulic components, hoses and O-rings. More efficient processing will extend the life of the attachment.

While most rail can be cut in any orientation, cutting just the head may ensure an easier break.

Poor rail breaking can be attributed to worn blades.

Regular maintenance and edge care can improve performance.

MAINTENANCE SAFETY

Only trained and authorized persons should perform maintenance on the attachment. To be qualified, you must understand the instructions in this manual, have training, and know the safety rules and regulations of the job site.

Do not alter the physical, mechanical or hydraulic operation of the attachment. Doing so may cause a dangerous situation for yourself and those around you and will void the warranty.

Do not attempt repairs you do not understand. If any questions arise regarding a safety or maintenance procedure, contact Genesis or your Genesis dealer.

Read this entire manual. All personnel must understand the maintenance and safety procedures.

Use factory authorized parts. The use of unauthorized parts may compromise safety, performance and durability of the attachment and may void the warranty.

Follow the daily checklist and maintenance schedules in this manual. Extreme conditions may dictate shorter maintenance intervals.

Do not exceed bolt torque specifications. See the Genesis Fastener Manual.

Do not weld on structural components without consulting Genesis. Doing so may cause structural failure and void the warranty.

Do not operate an attachment without the case-drain line properly installed if the attachment uses a rotation system that requires a case drain. Doing so will cause immediate failure of the rotate motor and gearbox.

Do not work on the attachment before ensuring it will not move. Completely lower the boom to the ground or a rest position and relieve hydraulic pressure.

Never operate poorly maintained equipment. When maintenance is required, repair or replace parts immediately.

Do not operate under unsafe conditions. If an unsafe condition arises during operation, immediately shut down the equipment and report the situation to the proper authority.

MAINTENANCE SAFETY

Do not work on any hydraulic lines or components while they are pressurized. Escaping hydraulic fluid can penetrate the skin, causing serious injury or death. Relieve pressure before performing maintenance. Keep hands and body parts away from pin holes and nozzles, which eject fluids under high pressure. Use a piece of cardboard to search for leaks.



If fluid is injected into the skin, seek medical assistance immediately from a doctor familiar with this type of injury.

NOTICE

See “Use Care with Hydraulic Fluid Pressure”, page 13

Hydraulic oil becomes hot during operation. Do not let hydraulic oil or components contact skin, as it could cause severe burns. Allow hydraulic components to cool before working on them. Use protective clothing and safety equipment.



Remove paint before welding or heating. Hazardous fumes/dust can be generated when paint is heated by welding, soldering or using a torch. Do all work outside or in a well ventilated area and dispose of paint and solvent properly.

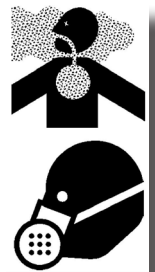

When sanding or grinding paint, avoid breathing the dust. Wear an approved respirator. If you use solvent or paint stripper, remove stripper with soap and water before welding. Remove solvent or paint stripper containers and other flammable materials from area. Allow fumes to disperse at least 15 minutes before welding or heating.

Avoid fire hazards. Keep the area clean. Remove all flammable materials from the area during any welding or heating process. Have a fire extinguisher nearby and know how to use it.



Never substitute pins or bolts. Use factory supplied pins. Replace all bolts with the same size and grade. Failure to do so may cause serious injury or death.

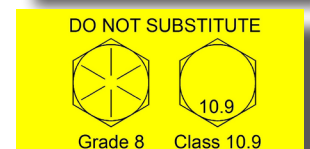

MAINTENANCE SCHEDULE

Performing scheduled maintenance will promote safe, reliable operation of your attachment. Inspect and grease components every eight hours of operation, as indicated on the following checklist. Use maintenance procedures described in this manual. If you are not able to safely and competently perform these procedures, have a Genesis dealer perform them.

After the first **80 hours** of operation, check all bolts, including slewing ring bolts.

Change gearbox lube after first **50 hours** of operation.

NOTICE

Extreme operating conditions may require shortened maintenance intervals.

Operating the attachment with excessively worn blades or main bearings could lead to premature cylinder failure. Excessive deflection of the upper jaw from these conditions will transfer side loading forces to the cylinder piston and barrel, which causes undue pressure on the wear bands of the piston, potentially resulting in cylinder failure.

Pounding the upper jaw lever arm or cylinder clevis on the ground or a hard object to clear a material jam can cause high pressure hydraulic spikes to the attachment and excavator which can damage the hydraulic system components. These spikes can damage the cylinder piston seals, which will allow oil to bypass and wash out the piston wear bands, resulting in premature and possibly catastrophic system failures.

Scheduled Maintenance

- ✓ Replace slewing ring bolts every 2000 hours.
- ✓ Reseal cylinder annually or after 2000 hours.
- ✓ Reseal swivel every 2 years or at the time of cylinder resealing.
- ✓ Check gearbox lube every 250 hours, change annually.

MAINTENANCE SCHEDULE

Four-Hour Checklist

Mid-shift, perform a brief visual check for hydraulic leaks, blade damage, and loose or missing bolts. A more thorough inspection, to be performed at the end of each shift, is described below on the eight-hour checklist.

Grease:

- Rail breaker cylinder - end of pin
- Rail breaker cylinder rod
- AutoGuide at fitting and smear grease on contact surface of upper jaw
- Main shaft/pivot, both sides

Grease all locations until grease extrusion is visible with jaw open and closed.

Eight-Hour Checklist

Inspect:

- Bolts - check for loose bolts, replace if damaged
- Fittings and hoses for damage or leaks
- Bracket pivot for wear and pin retainers
- Cylinder pivot for wear and pin retainers
- Entire attachment for cracks (visual check)

Grease:

- Bracket pivot
- Bracket cylinder
- Slewing ring bearing (five locations)
- All points listed in 4-hour checklist

Grease all locations until grease extrusion is visible.

Jaws and Blades:

- Check blade edge radiuses*
- Check for loose or damaged bolts, re-torquing loose bolts when cool
- Check AutoGuide and shim if needed
- Build-up and hard-surface as required
- Grind off any rolled-over or mushroomed blade edges
- Shear Jaw Armor[®] - build-up and hard-surface as needed

* See Blade Maintenance information in this manual regarding maximum gap and radius for your specific attachment model. Blade gaps should be checked and maintenance performed when the attachment has cooled to ambient temperature.

LUBRICATION POINTS



Shut off excavator and disable hydraulics per OEM instructions before greasing.

For normal conditions above 32°F (0°C), use a lithium-based, premium grade 2 extreme-pressure grease. For temperatures below 32°F, use a grade 0 grease.

Do not use grease containing Molybdenum (Moly).

Genesis GLG-2® anti-wear, extreme-pressure lithium grease, PN 6302601, is recommended for all temperature conditions.

The attachment jaws must be closed for access to all grease fittings. Grease all fittings every four to eight hours of operation (see Maintenance Schedule).

After greasing the rotation bearing, rotate the attachment through two full rotations.

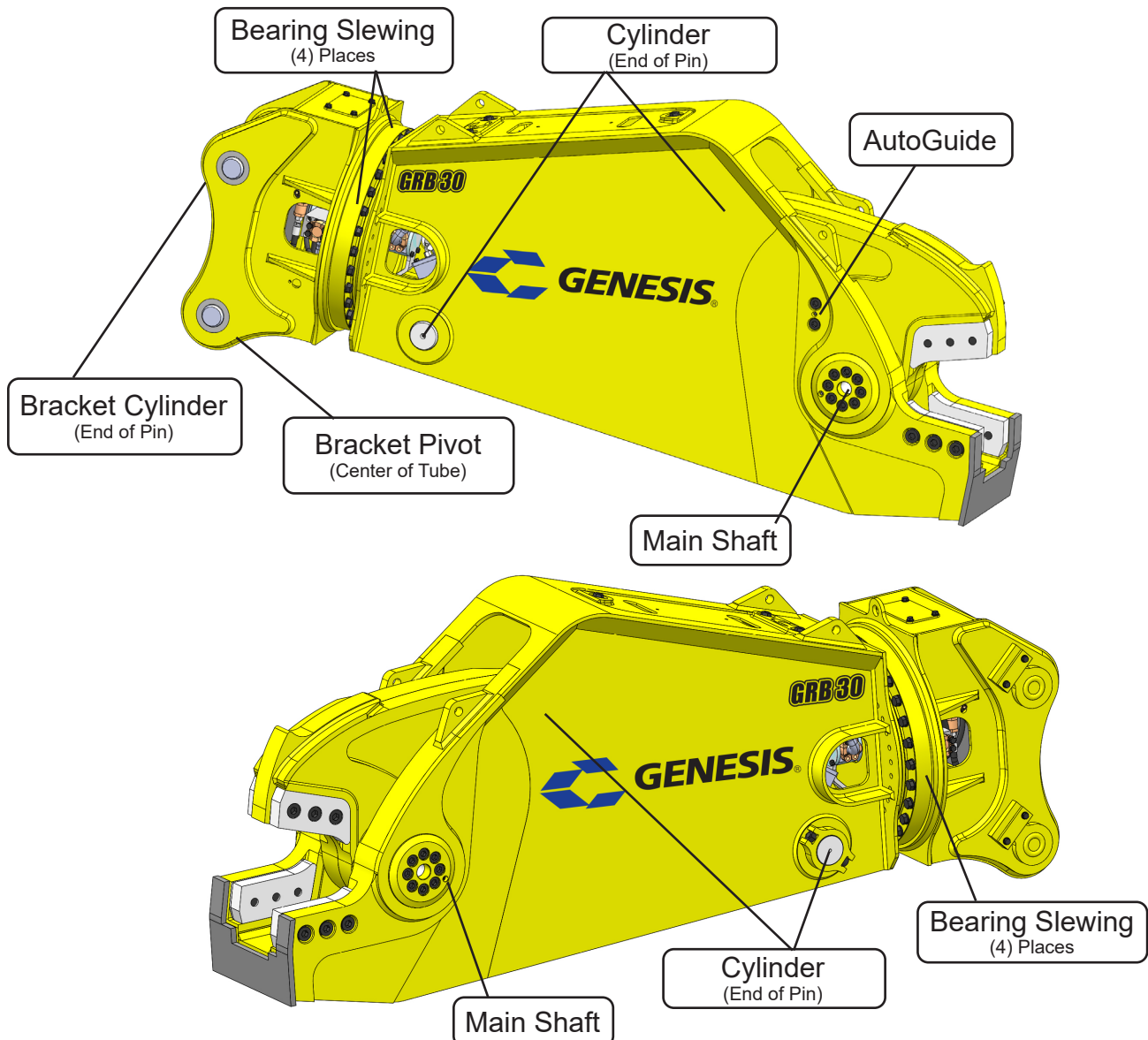

BOLT TORQUE SPECS

**Bolt torque specs and thread treatment procedures can be found in the
Genesis Fastener Manual.**

genesisattachments.com/manuals

BLADE MAINTENANCE

Blade and blade seat maintenance greatly affects performance. To maximize cutting performance and optimize the life of replaceable parts, follow this specific sequence of checks, adjustments and maintenance.

1. AutoGuide - shim to tolerance and replace when shims exceed 0.100".
2. Upper and Lower Cutting Blades - identical, non-rotating blades, grind rolled edges as needed, replace when worn.
3. Guide Blades - non-rotating blades designed to prevent jaw wear. These are not the primary blades for cutting rail.
4. Jaw Hard-surfacing - build-up and hard-surface as needed.
5. Shear Jaw Armor[®] - Build-up or replace as wear out.

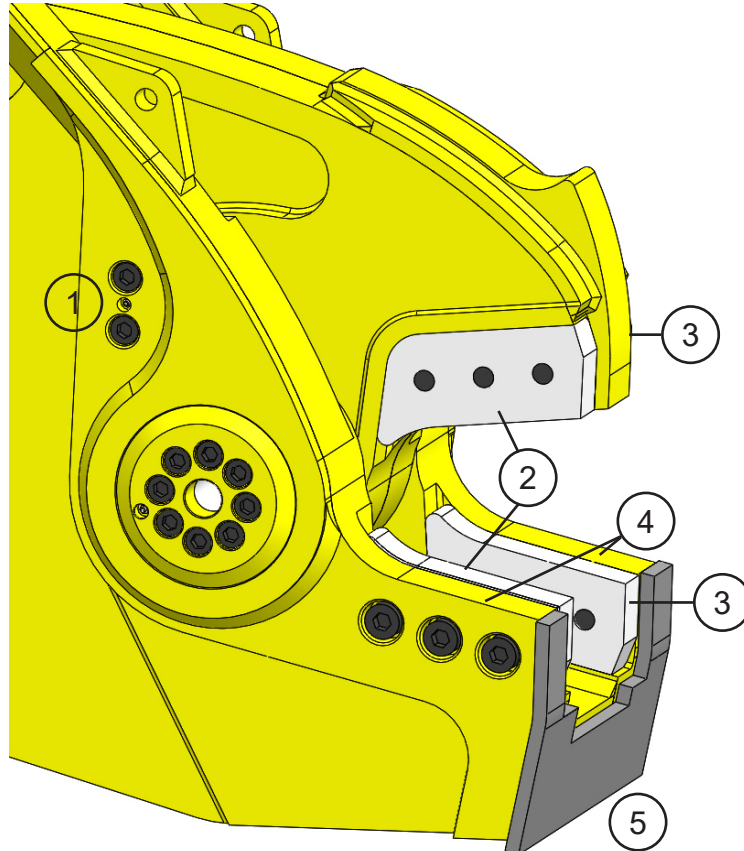

AUTOGUIDE

The AutoGuide (or puck) makes light contact with the wear surface of the upper jaw to maintain proper jaw alignment. Check the puck daily for wear or damage, replacing when grease grooves are no longer visible.

Tolerances between the puck and the wear surface should be 0.005" to 0.010".

- ✓ Check tolerances every eight hours of operation and shim as needed.
- ✓ Never overtighten the puck against the wear surface.
- ✓ Perform puck maintenance and shimming before performing blade maintenance.

AutoGuide Adjustment Procedure

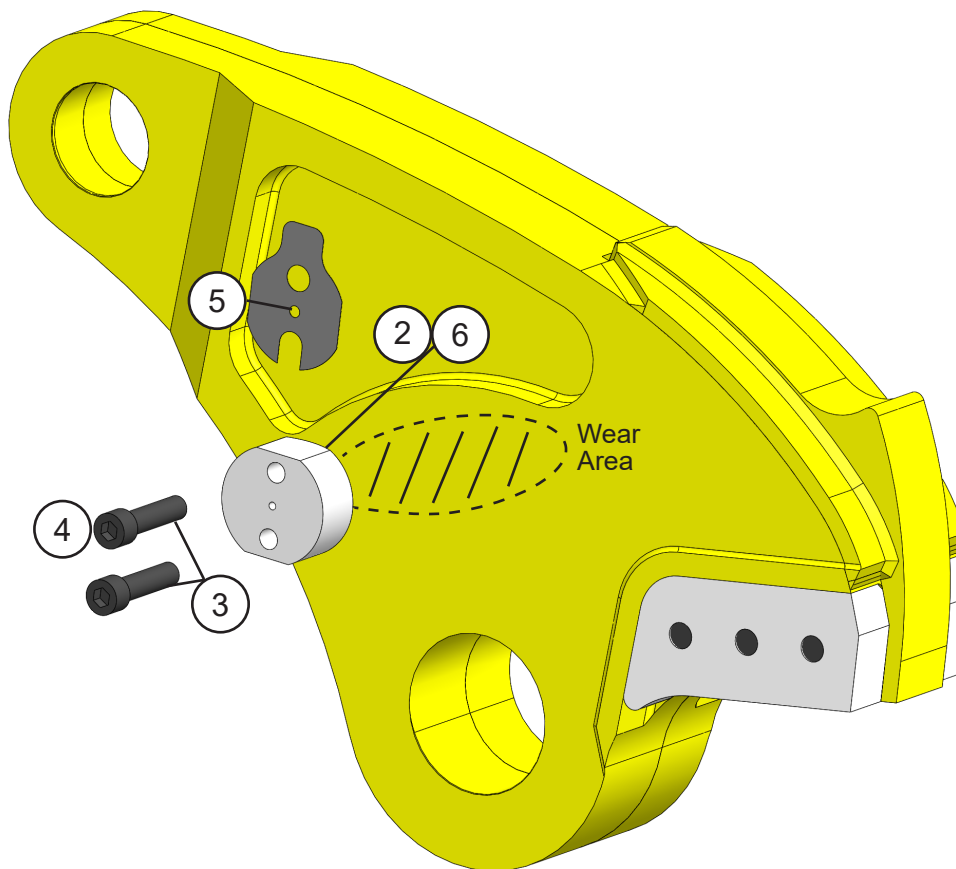

Use the following procedure to maintain the proper gap and shim the puck.

1. Slowly close the upper jaw until the puck is centered on the wear area.
2. Check the gap, using a feeler gauge or shims.
3. Loosen the bolts on the outside of the stick.
4. Completely remove the upper bolt.
5. Insert shims, insert top bolt, tighten both bolts.
6. Check gap with feeler gauge.

GUIDE BLADES

Guide blades are designed to prevent jaw wear, not to cut. The gap between the guide blades should be 1/2-inch.

Rotation

GRB blades can not be rotated. They must be replaced when worn. This prevents the blade pockets from damage. The severe application of rail cutting makes this necessary.

Shims

The GRB does not require guide blade shims because the blade gap is set with the pivot shims. The blade gap should be approximately 1/2-inch. If the blade gap is less than 1/4-inch, contact Genesis for further instruction.

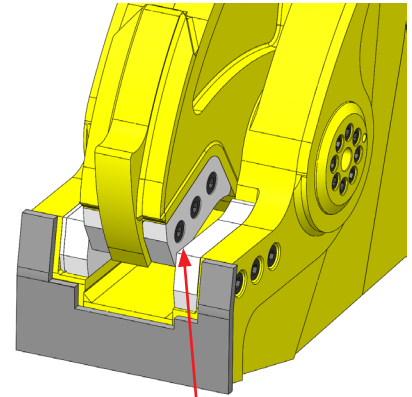

Blade Gap Location
1/2-inch gap

CUTTING BLADES

Blade Gap

The GRB blades do not require shimming because there is no blade rotation. Inspect blades every eight hours, and grind dents or mushroomed edges.

Cutting Blade Gaps		
Minimum	Factory	Maximum
0.030"	0.060"	0.090"

Blade Gap Location

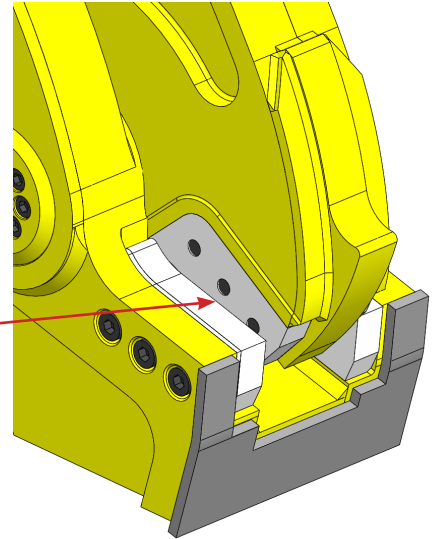

Blade Gap Measuring Procedure

To check the blade gap, install new blades, and then slowly close the jaws until the blades begin to bypass. Stop the jaw and check the gap with a feeler gauge.

Cycle the jaws slowly and continue checking the gap at several points along the entire length of the blades.

If the blade gap exceeds the maximum listed on the table above, shim the pivot group.

Adjustment Plates

Do not remove the blade adjustment plate from the lower jaw during routine blade maintenance or replacement. These plates are custom-machined for each attachment and need only be replaced when lost, damaged or extremely worn.

Inspect the top of the adjustment plate for burrs, nicks or other imperfections that may prevent proper seating of the blade and cause errant blade gap readings. Clean the adjustment plate as necessary. Inspect the blade seat for damage or imperfections and clean or repair as necessary.

Replacement plates can be ordered from your Genesis dealer or the Genesis Parts Department with the serial number of your attachment.

CUTTING BLADES

Proper maintenance of the cutting blades is required for optimal performance. Dull blades make the excavator hydraulic system work harder and may cause structural damage to the attachment.

Inspect blades every eight hours of operation. Re-torque loose bolts and replace broken bolts. Grind away dents or mushrooming of blade edges at the end of each day to prevent upper jaw deflection, excessive blade wear and undue stress to upper and lower jaws.

Always use Genesis-approved blades. Blades that do not meet Genesis specifications can cause major problems, and using them may void the warranty.

Before performing any blade maintenance, read, fully understand and follow these safety rules.

Wear personal safety equipment including gloves, safety glasses, safety boots and proper clothing.

Safe blade maintenance requires two people - one to steady the blade while the other loosens the bolts.

Blades are heavy and may fall out of the blade seat if not adequately supported. Bystanders must stand clear.

Never strike a blade with a hardened steel tool. The blade may fragment, creating sharp flying debris.

GENERAL WELDING GUIDELINES

Build-up and hard-surfacing are welding procedures that protect the parent material of the jaws and keep the blades in good adjustment. Build-up is the welding procedure that restores the jaws to their original shape. Building up the jaws helps protect the blades and increases the life of the attachment. Hard-surfacing is the welding material added over the parent material (or build-up material) to create a wear-resistant surface.

Welding should not be performed until the jaws are work-hardened. Work-hardening can take up to 80 hours. However, jaws must not wear lower than the height of a new blade. If either jaw wears down lower than blade height, immediately stop operating the attachment and perform build-up and hard-surfacing as described in the following pages of this manual.

When welding around blade seats or the piercing tip tang area, maintain the factory machined seat radius. If the rounded grooves are welded up, use a die grinder with a carbide tool to recut these areas to their original profile. Leaving a squared edge will eventually cause structural cracking. The radius provides a broader area to absorb structural stress.

Welding Ground Clamp

Disconnect all battery ground cables or shut off master battery switch, if equipped. Failure to do so may cause excavator electrical problems, including permanent damage to onboard computer systems.

Connect ground clamp as close as possible to the area being welded without allowing current to pass through the pivot group, cylinder pin, cylinder, swivel, motor, gearbox or slewing ring.

If you are welding on the lower jaw, connect weld clamp to the lower. If you are welding on the upper jaw, connect to the upper but not to the cylinder clevis. If needed, weld a piece of steel to the area for the grounding clamp and cut the piece off when welding is completed.

Welding Rules

Before you begin:

- Remove adjacent blades, as preheating and welding may cause blade damage.
- Wearing an approved respirator, grind the area to clean it, removing all existing hard-surfacing.
- Preheat area to 350° F (177° C). Maintain this temperature throughout the procedure. Do not exceed 450° F (232° C) interpass temperature.

During welding:

- Always grind and weld with the grain of the material.
- Peen each weld pass to relieve stress and harden the welds.
- Do not undercut the ends of the welds.
- Do not start or stop welds directly above a bolt hole or in the apex of the jaw.

After welding maintenance is complete:

- Cover the area with a heat blanket and allow it to cool slowly, approximately eight hours.
- Do not put the attachment into operation until the welds have been allowed to cool.

BUILD-UP

Procedure:

Follow the General Welding Guidelines and Rules.

Determine the area to build up, using a straight-edge or square. Jaws must not wear lower than the height of a new blade. Use a new blade to help determine build-up height for the jaw.

Build up the jaw to slightly higher than the original parent material profile with E7018. Apply single passes in each line with the grain of the steel, peening after each pass.

Protection strips, or raised areas under or around blade seats, must be built up and maintained during build-up procedure using E7018 or equivalent.

These areas should be maintained between blade height and 0.010" lower than blade height. These areas protect the bottom unused edges of the blades as well as reduce the chance for material to catch on the bottom of the blade during jaw open functions, which causes blades to move in their seats.

Denting, deformation or build-up higher than blades in these areas may cause upper jaw deflection, excessive blade gaps, wear to blade faces and undue stress to upper and lower jaws.

After build-up is complete, grind material to be flush with a new blade.

Note: Closely monitor areas above guide blade bolt countersinks and below front two upper blade bolt countersinks. These are high-wear areas. If allowed to wear too far, parent material starts to fold into the countersinks, and it becomes time-consuming to clean out this area when access is needed for blade rotation and replacement.

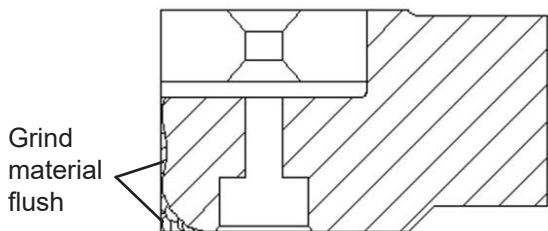
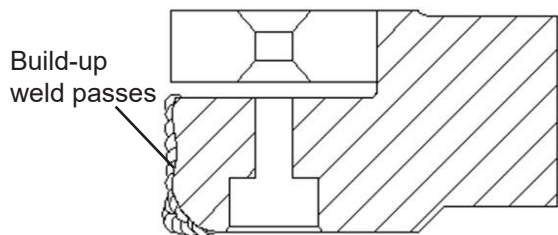
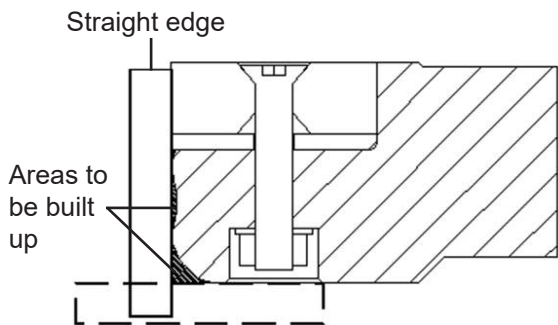

HARD-SURFACING

Do not apply hard-surfacing directly to the parent material as this could cause toe cracking, and the hard-surfacing will break away.

Procedure:

Follow the General Welding Guidelines and Rules.

Apply a single pass stringer bead pattern, with the grain, using E7018 electrode. Peen each pass.

Do not apply a stringer directly on the edge. Start the first pass 1/4" from the edge.

Stagger the ends of the stringer welds so they do not end in a straight line.

Cap each stringer bead with one pass of GenWire or GenRod to hard-surface. Do not apply more than two layers of hard-surfacing. Peen each pass.

Grind the ends of all stringer welds, with the grain to taper 1" to 1-1/2" (25 - 38 mm) to the parent material.

See the following page for hard-surfacing illustrations and instructions specific to each area of the jaws.

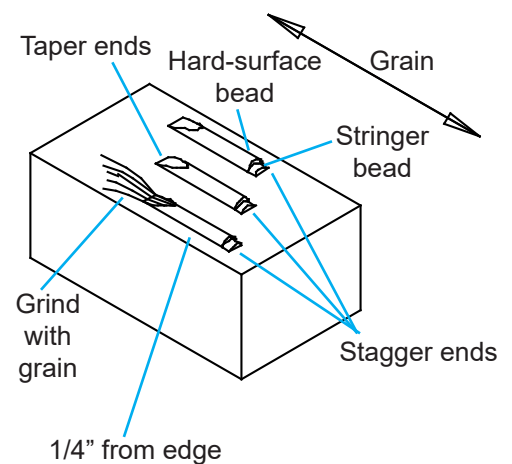

HARD-SURFACING PATTERNS

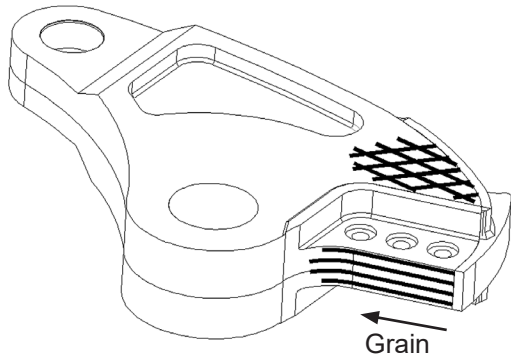

Upper Jaw

Single passes approximately 1" apart. Begin just behind the piercing blade seats and continue toward the throat. Use three to five stringers as shown.

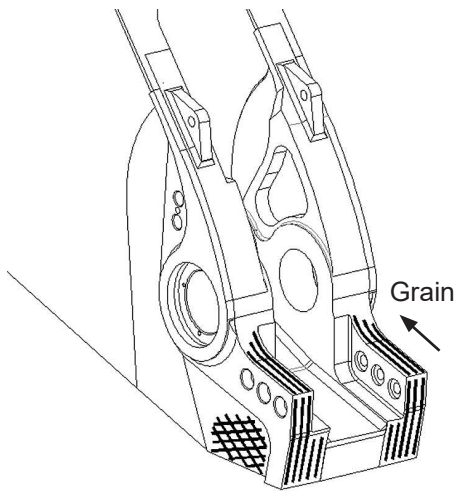

Lower Jaw

Single passes approximately 1" apart. Work across the top of the chin plate and along the lower jaw toward the throat. Use two to three stringers as shown.

HYDRAULIC/ROTATION MAINTENANCE

Hydraulic Requirements

Operating the attachment below the recommended flow and/or pressure range will adversely affect performance and may damage the rotate motor.

Operating the attachment above the recommended flow and/or pressure range may damage the attachment and its hydraulic components.

Flow	Pressure
73-110 GPM	3500 - 4000 PSI
276-416 LPM	241 - 275 Bar

Rotation Valve Input

For cooler and more efficient hydraulic system operation, set the input pressure as indicated in the chart below.

The maximum case drain pressure measured at the attachment while rotating and cycling the jaws must never exceed 80 PSI. Pressure increases during cold-weather operation.

Flow	Pressure
5-7 GPM	1800-2000 PSI
19-26 LPM	125-138 Bar

SLEWING RING MAINTENANCE

Visually check slewing ring (rotation bearing) bolts every eight hours of operation. Do not reuse or re-torque these bolts. Loose or broken bolts, along with the bolts on either side, must be immediately replaced.

The bolts that secure the slewing ring are critical for safe attachment operation. Improper torque may cause the bolts to fail and the attachment to break free, which may result in serious personal injury and equipment damage. Improper torque will also cause uneven slewing ring wear.

Rotating components must be greased daily. Grease fittings are located on the outside of the slewing ring and on the inside of the rotating head assembly. Grease locations are marked with decals.

Grease each fitting and then rotate the attachment two full rotations.

For normal conditions above 32°F (0°C), use a lithium-based, premium grade 2 extreme-pressure grease. For temperatures below 32°F, use a grade 0 grease. **Do not use grease containing Molybdenum (Moly).**



Genesis GLG-2[®] anti-wear, extreme-pressure lithium grease, PN 6302601, is recommended for all temperature conditions.



Stand clear when the attachment is being rotated. Always stay in clear view of the operator.

ROTATION MOTION CONTROL VALVE ADJUSTMENT

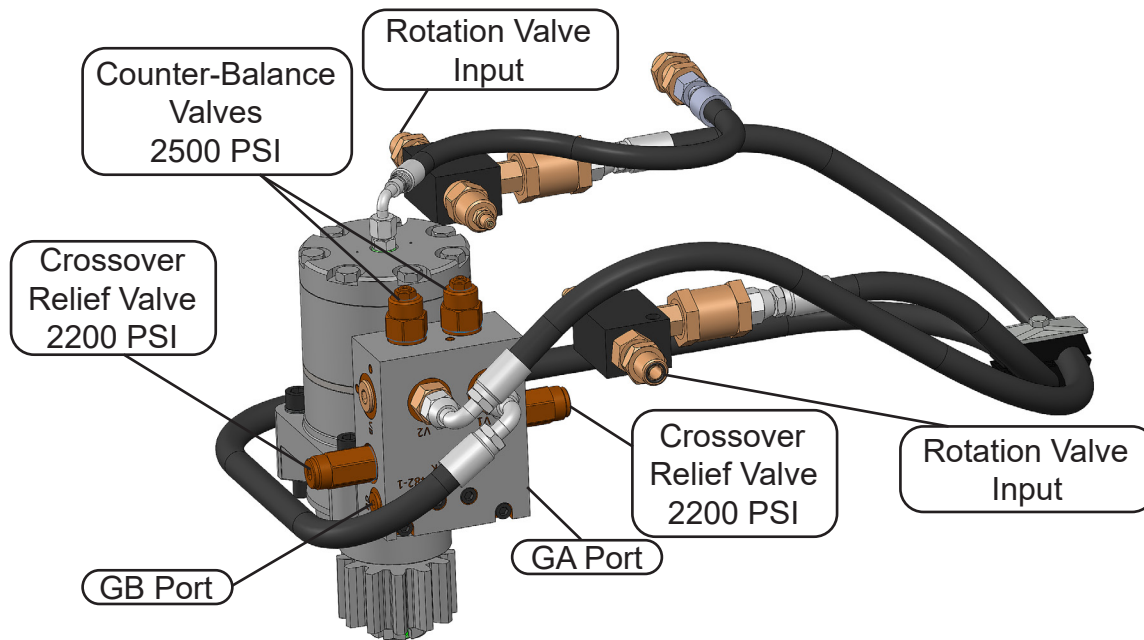

Adjusting the Rotation Motion Control Valve

1. Adjust the supply pressure to the motion control valve to 2700 PSI.
2. Install gauges rated for at least 3000 PSI into the motion control manifold GA and GB ports.
3. Turn the crossover relief valve adjusting screws clockwise (in) to the maximum setting, while recording the number of turns, so they can be returned to their original settings.
4. Adjust the counter-balance valves with the attachment stalled on the ground until each side is adjusted to 2500 PSI. You will need to reverse the rotate direction with the attachment stalled on the ground to adjust the valves independently of each other.
5. Turn the crossover relief valve adjusting screws counter-clockwise (out) to their original settings. Again, stall the shear in each direction to verify the screws have returned to their original 2200 PSI setting. If they have not, adjust to 2200 PSI.
6. Reduce the rotation valve input pressure as indicated on page 42.

TROUBLE-SHOOTING GUIDE

Symptom	Possible Causes/Solutions
Low power	Check operating pressures and back pressure at port blocks on attachment
	Isolate attachment from excavator and check excavator pressures at boom tip
	Possible cylinder or swivel bypass - contact the Genesis Service Department for procedures to check for bypass
Slow jaw close	Check hydraulic flows from excavator
Jaw drifts closed or can be pushed closed	Directional valve on excavator may be leaking
	Possible cylinder or swivel bypass - contact the Genesis Service Department for procedures to check for bypass
	Possible cylinder or swivel bypass - contact the Genesis Service Department for procedures to check for bypass
Jaw closes suddenly and will not open	Ball valve may be closed on excavator
	Excavator valve spool may be stuck
	If attachment has quick-coupled hydraulics, they may be partially disconnected or damaged
Hydraulic system overheating	Check hydraulic system oil level for low or overfull condition
	Ensure clear path for hydraulic cooler-radiator and A/C condenser; clean coolers and radiator with compressed air and then pressure wash
	Check with excavator dealer on whether a hot weather package needs to be installed on the excavator. Note oil temperatures coming out of the attachment can run as high as 230 to 240 degrees Fahrenheit.
Poor Cutting	Wear in main bearings is causing jaw deflection and inconsistent blade gaps
	Pressures from excavator too low - check at attachment port blocks
	Swivel or cylinder is bypassing - contact the Genesis Service Department for procedures to check for bypass

TROUBLE-SHOOTING GUIDE

Symptom	Possible Causes/Solutions
Does not rotate	Blown fuse
	Test for 24V at plugs on directional valve while depressing foot switch
	Incorrect pressure settings; reset
Does not rotate in one direction	No electrical power to one side; test for 24V at plugs on directional valve while depressing foot switch
	Check if directional control valve shifts both ways while actuating foot switch in both directions
Rotator chatters	Electrical short; back out flow controls
	Pressure settings too high; reset
	Power to both rotation solenoids at the same time; test for 24V at plugs on directional valve while depressing foot switch
Rotates faster in one direction	One flow control cartridge is set higher than the other; reset
Rotates too fast or too slow	Flow control out of adjustment; reset
Rotation speed changed from original setting	Jam nut loosened on rotation valve
	Faulty cartridge (contamination)
	Faulty directional control valve
	Pressure set too low; reset

WARRANTY

Claim Procedure

Notify the Genesis Service Department of the potential warranty claim prior to making the repair. Digital pictures are very helpful for diagnosing problems and recommending repairs.

Contact the Genesis Service Department before making alterations, changes or repairs to any component that is going to be considered for warranty. Not doing so will void all Genesis warranty consideration.

The Genesis Service Department will issue an authorization number to track the repair costs, outgoing parts, and/or defective parts returning to the factory.

Replacement parts must be ordered using a purchase order number. Shipping is standard ground. Overnight shipping is available by request, and Genesis will not cover the shipping charge.

When the repair is complete, submit an invoice to the Genesis Service Department within 30 days. Include itemized internal labor reporting, parts lists and invoices for outside contractors. Reference the authorization number on all invoices.

When returning parts for warranty consideration, include a copy of any related Genesis paperwork along with any other necessary documentation to ensure proper processing and credit. The Genesis Service Department will provide the necessary forms.

Your account will be credited when the warranty claim is accepted.

Blade Warranty

Standard warranty on blades will only be considered on one edge, and wear on the edge must be 1/8" radius or less. Genesis does not warranty cutting blades that are cracked or broken from top to bottom (perpendicular to the long edge of the blade). Genesis also does not cover fasteners, the labor to replace wear components or collateral damage, such as blade seats, from broken blades, the piercing blade tang or adjustment plates.

Please direct any questions to the Genesis Service Department: 715-395-5252

PARTS ORDER POLICY AND PROCEDURE

Parts Orders Should Include

- Purchase order number
- Model and serial number of attachment
- Part number and quantity needed
- Shipping and billing address
- Method of shipment or required delivery date

Placing Orders

Orders may be placed by phone or e-mail. To e-mail an order, use the form on the following page or your purchase order form. Contact information is located at the front of this manual.

Part Numbers

Part numbers are listed in a separate Parts Manual or, if included, the Parts section of this manual. Contact the Genesis Parts Department with questions regarding part numbers, availability and pricing.

Shipping

All orders will be shipped best way surface unless an alternate shipping method is requested. Shipping charges are not included in the purchase price of parts.

Invoices

All invoices are due upon receipt. Any accounts with invoices open beyond 60 days are subject to review and may be placed on C.O.D. status without further notice.

Returns

Many unused Genesis parts may be returned with proper documentation. Return shipping is the responsibility of the purchaser. Credit will be issued upon return, less a 25% restocking fee. Documentation is required for credit of returned parts. Contact the Genesis Service Department at 715-395-5252 for an RGA (Return Goods Authorization) number and form. An RGA must accompany every return. Items shipped without an RGA may be returned to sender.

Warranty Returns

All parts returned to Genesis for warranty consideration must be returned with a completed RGA (Return Goods Authorization) provided by the Genesis Service Department. The form needs to be completed in its entirety, including any additional information requested by the Service Department. Return shipping is the responsibility of the sender and will be credited upon claim approval. A determination to accept or deny the claim will be made based upon the information available to Genesis. Warranty on purchased parts other than wear components is 6 months. Genesis does not cover labor costs to replace purchased parts replaced under warranty. There is no warranty period on wear parts or components.

Customer: _____ Date: _____

Phone: _____ Contact: _____

Shipping Address: _____ E-mail: _____

_____ Billing Address: _____

Purchase Order: _____ Shipping Method: _____

Model: _____ Serial Number: _____

Quantity	Part Number	Description	Price

E-mail to the Genesis Parts Department: genesisparts@genesisattachments.com
For assistance, call 715-395-3488



GENESIS®

The Promise of Performance.

CONTACT INFORMATION

Genesis Attachments

1000 Genesis Drive
Superior, WI 54880 USA

Toll Free: 888-Attachment-IT
(888-743-2748)

Phone: 715.395.5252

E-mail:
info@genesisattachments.com

Europe/Africa/Middle East Genesis GmbH

Teramostrasse 23
87700 Memmingen, Germany

Phone: +49 83 31 9 25 98 0

Fax: +49 83 31 9 25 98 80
genesis-europe.com

E-mail:
info@genesis-europe.com

Asia Pacific Representative Office

24 Upper Serangoon View #12-28
Singapore 534205

Phone: +65 9673 9730

E-mail:
tchoo@genesisattachments.com

Central America & Colombia

Cra 13A #89-38 / Ofi 613
Bogota, Colombia

Phone: +57 1 610 8160 / 795 8747

E-mail:
contact@themsagroup.com

View and download all manuals: genesisattachments.com/manuals
Patents: genesisattachments.com/products/patents

Rev. 3-27-25