

XT Mobile Shear

Reference Guide

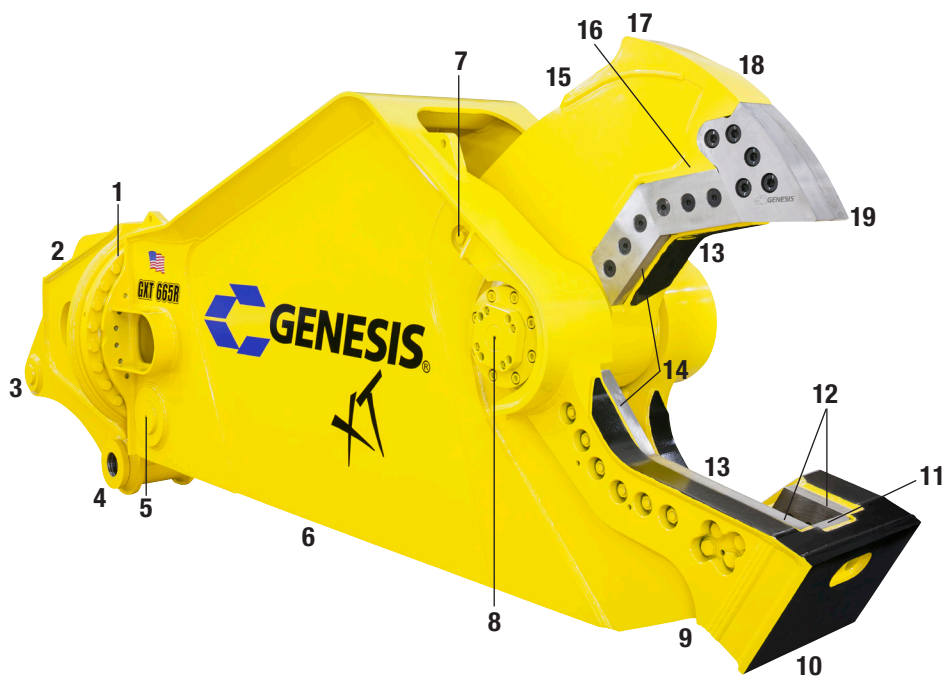



1	Slewing ring – connects the shear head to the shear stick or body; not used on straight shears
2	Sub-head – houses and protects the hydraulic components used for 360° rotation
3	Stick-pin connection location or linkage connection on 3 rd member applications
4	Boom pivot connection location or stick-pin connection on 3 rd member applications
5	Rear cylinder pin for the main cylinder
6	Stick or body – houses and protects the main hydraulic cylinder
7	AutoGuide or puck bolts – the dry torque value for these bolts on all GXT shears is 900 ft-lb
8	Pivot group – includes the end cap, tie rod and tie rod nut
9	Lower shear jaw
10	Chin – keep top edge built up, maintain radiuses in razor blade pocket after build-up and hard-surfacing
11	Razor blade – NEVER insert shims behind
12	Dual guide blades – insert shims between the adjustment plate and blade when setting/adjusting blade gap <i>Note: from the operator's view, the left guide blade may or may not have an adjustment plate. If not, insert shim(s) directly against the back of the guide blade.</i>
13	Upper and lower secondary cutting blades. Only insert shims behind the lower, placing between the adjustment plate and blade when setting/adjusting blade gap.
14	Upper and lower primary cutting blades. Only insert shims behind the lower, placing between the adjustment plate and blade when setting/adjusting blade gap.
15	Upper shear jaw – never shim blades in upper jaw
16	Protection strips – raised areas of parent material along the blade pockets on upper and lower jaws, should be flush to 0.010" below the blade faces
17	Rhino horn
18	Tang – parent material under and between the piercing tip blades
19	Piercing tip blades – NEVER insert shims behind

4-HOUR CHECKLIST

Every four hours, perform a brief visual check for hydraulic leaks, blade damage, loose or missing bolts, and cylinder pin keepers. A more thorough inspection, to be performed at the end of each shift, is described below on the eight-hour checklist.

- Grease:**
- Shear cylinder - end of pin
 - Shear cylinder rod
 - AutoGuide at fitting and smear grease on contact surface of upper jaw
 - Main shaft/pivot, both sides

Grease all locations until grease extrusion is visible with jaw open and closed.

8-HOUR CHECKLIST

- Inspect:**
- Bolts - check for loose bolts, replace if damaged
 - Fittings and hoses for damage or leaks
 - Bracket pivot for wear and pin retainers
 - Cylinder pivot for wear and pin retainers
 - Entire shear for cracks (visual check)

- Grease:**
- Bracket pivot
 - Bracket cylinder
 - Bearing slewing - four locations
 - All points listed in 4-hour checklist

Grease all locations until grease extrusion is visible.

- Jaws and blades:**
- Check blade gaps, see page 7 for minimum and maximum
 - Check blade edge radiuses
 - Check for loose or damaged bolts, retorquing loose bolts when cool
 - Check AutoGuide, shim to tolerance and replace when shims exceed 0.100"
 - Build-up and hard-surface as required
 - Grind off any rolled-over or mushroomed blade edges
 - Shear Jaw Armor® - build-up and hard-surface as needed

Piercing Tip Wet Bolt Torque

Model	Ft-lb
115 & 225	320
335 - 555	772
665 - 2555	1545

Cutting Blade Wet Bolt Torque

Model	Ft-lb
115 & 225	256
335 - 555	412
665 - 2055	617
2555	1236

Razor and Guide Blade Wet Bolt Torque

Model	Ft-lb
115 & 225	256/320*
335 - 555	515
665 - 2055	772
2555	772/1545**

Grease the bolt threads and under the bolt head.

These values are for standard countersunk bolts only. Tapped blades and bolts will vary.

*Hex and socket head bolts have a higher torque value. Flat head bolts have a lower torque value.

**A 1-inch bolt has a lower torque value. A 1.5-inch bolt has a higher torque value.

This document is a quick reference only. It does not replace the GXT Safety and Operator's Manual, which must be

Shut off excavator and disable hydraulics per OEM instructions before greasing.



GREASE

For normal conditions above 32°F (0°C), use a lithium-based, premium grade 2 extreme-pressure grease. For temperatures below 32°F, use a grade 0 grease.

Do not use grease containing Molybdenum (Moly).

Genesis GLG-2[®] anti-wear, extreme-pressure lithium grease, PN 6302601, is recommended for all temperature conditions.

The shear jaws must be closed for access to all grease fittings. Grease all locations per the 4- and 8-hour checklists on page 4 until grease extrusion is visible with the jaw open and closed.

After greasing the rotation bearing, rotate the shear through two full rotations.



Grease locations:

1. Bracket pivot - center of tube
2. Bracket cylinder - end of pin
3. Shear cylinder - end of pin
4. Shear cylinder - end of pin
5. Main shaft/pivot - both sides
6. Bearing slewing - four locations
7. AutoGuide
8. AutoGuide contact surface on upper jaw

BLADE MAINTENANCE

Blade and blade seat maintenance greatly affects performance. To maximize cutting and optimize replacement part life, follow this sequence of checks, adjustments and maintenance.

AutoGuide

Shim to tolerance and replace when shims exceed 0.100" (2.5mm).

Piercing Blades

For models GXT 115 - GXT 2055, a gap of 0.002" - 0.010" (.05 - .25mm) where the blades meet is required. For GXT 2555, the gap is 0.030" - 0.035" (.76mm - .89mm). See **A** on the graphic on page 7.

The acceptable gap between the piercing blades and razor blade is 5/8" (16mm). See **B** on the graphic on page 7.

Badly worn blades must be replaced. Slightly worn blades may be repeatedly squared with a grinder and square until a maximum of 1/2" (13mm) of material has been removed from the lower piercing edge.

The blade width, top to bottom, may taper 0.060" (2mm) total. Bottom edges may be worn to a maximum radius of 3/16" (5mm).

Red areas require an air gap, and blades may occasionally need to be ground to provide clearance.

Piercing blade contact with the clearance areas (**red**) can cause abnormal stress in the blade. This may cause the piercing and/or guide blades to crack, break or shatter.

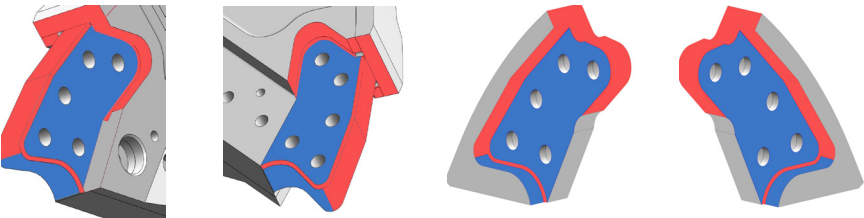

Blue areas require contact fit to the upper jaw and tang to prevent shattering.

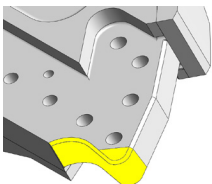

Yellow area - when necessary, build up the front lower edge of the tang. After welding, surfaces should be squared with a grinder and finished with a file and machinist's straight edge.

It's critical the piercing blade pocket and tang surfaces are straight and true, without dings, deformations, high or low spots, or worn away areas.

Guide Blades

Rotate when worn to a 1/8" (3mm) radius.
 Replace a guide blade when more than 0.075" (2mm) of shims are required to keep the blade gap within tolerance. See **C** in the graphic below for blade gap location.

Cutting Blades

Rotate when the cutting edges are worn to a 1/8" (3mm) radius.

Recommended rotation intervals are approximately 40-80 hours, depending on the material being processed. Thin materials may require shorter rotation intervals. Blades must be replaced when all four edges are worn to 1/8" (3mm) radius.

Do not use more than 0.060" (2mm) of shims to bring into tolerance. Blades must be replaced when shims exceed 0.060" (2mm). See **D** in the graphic below for blade gap location.

Guide Blade To Piercing Tip Gaps

Model	Minimum	Maximum
115 - 555	0.010"	0.020"
665 & 775	0.015"	0.025"
995 & 1555	0.020"	0.030"
2055 & 2555	0.025"	0.035"

Cutting Blade Gaps

Model	Minimum	Maximum
115 - 335	0.005"	0.015"
445 - 775	0.010"	0.020"
995 & 1555	0.015"	0.025"
2055 & 2555	0.020"	0.030"

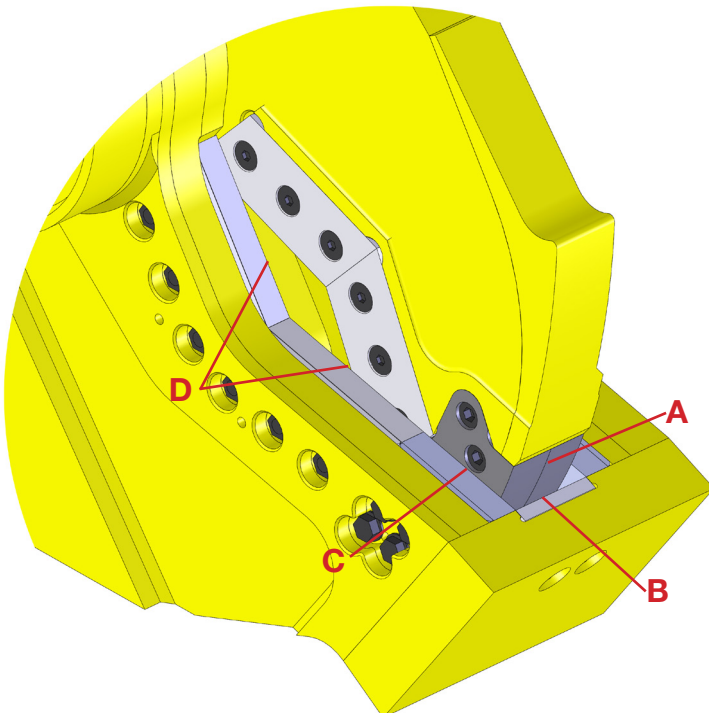

GENERAL WELDING GUIDELINES

When welding around blade seats or the piercing tip tang area, maintain the factory machined seat radius. If the rounded grooves are welded, use a die grinder with a carbide tool to recut these areas to their original profile. Leaving a squared edge will eventually cause structural cracking. The radius provides a broader area to absorb structural stress.

Welding Ground Clamp

Disconnect all battery ground cables or shut off master battery switch, if equipped. Failure to do so may cause excavator electrical problems, including permanent damage to onboard computer systems.

Connect ground clamp as close as possible to the area being welded without allowing current to pass through the pivot group, cylinder pin, cylinder, swivel, motor, gearbox or slewing ring.

If you are welding on the lower jaw, connect weld clamp to the lower. If you are welding on the upper jaw, connect to the upper but not to the cylinder clevis. If needed, weld a piece of steel to the area for the grounding clamp and cut the piece off when welding is completed.

Welding Rules

Before you begin:

- Remove adjacent blades, as preheating and welding may cause blade damage.
- Wearing an approved respirator, grind the area to clean it, removing all existing hard-surfacing.
- Preheat area to 350°F (177°C). Maintain this temperature throughout the procedure. Do not exceed 450°F (232°C) interpass temperature.

During welding:

- Always grind and weld with the grain of the material.
- Peen each weld pass to relieve stress and harden the welds.
- Do not undercut the ends of the welds.
- Do not start or stop welds directly above a bolt hole or in the jaw apex.

After welding maintenance is complete:

- Cover the area with a heat blanket and allow it to cool slowly, approximately eight hours.
- Do not put the shear into operation until the welds have been allowed to cool.

BUILD-UP

Procedure:

Follow the General Welding Guidelines and Rules

Determine the area to build up, using a straight-edge or square. Jaws must not wear lower than the height of a new blade. Use a new blade to help determine build-up height for the jaw.

Build up the jaw to slightly higher than the original parent material profile with E7018. Apply single passes in each line with the grain of the steel, peening after each pass.

Protection strips, or raised areas under or around blade seats, must be built up and maintained during build-up using E7018 or equivalent.

These areas should be maintained between blade height and 0.010" (.25mm) lower than blade height. These areas protect the bottom, unused edges of the blades as well as reduce the chance for material to catch on the bottom of the blade during jaw open functions, which causes blades to move in their seats.

Denting, deformation or build-up higher than blades in these areas may cause upper jaw deflection, excessive blade gaps, wear to blade faces and undue stress to upper and lower jaws.

After build-up is complete, grind material to be flush with a new blade.

Note: Closely monitor areas above guide blade bolt countersinks and below front two upper blade bolt countersinks. These are high-wear areas. If allowed to wear too far, parent material starts to fold into the countersinks, and it becomes time-consuming to clean this area when access is needed for blade rotation and replacement.

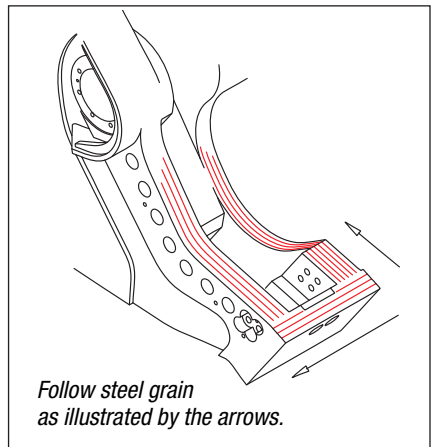
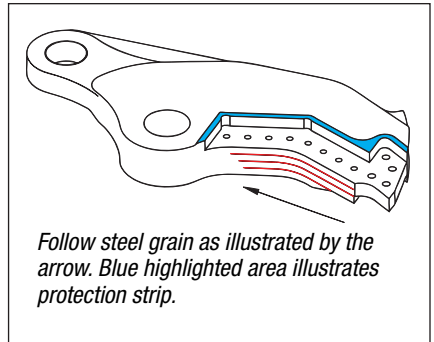

HARD-SURFACING

Do not apply hard-surfacing directly to the parent material as this could cause toe cracking, and the hard-surfacing will break away.



Procedure:

Follow the General Welding Guidelines and Rules

- Apply a single pass stringer bead pattern, with the grain, using E7018 electrode. Peen each pass.
- Do not apply a stringer directly on the edge. Start the first pass 1/4" (6mm) from the edge.
- Stagger the ends of the stringer welds so they do not end in a straight line.
- Cap each stringer bead with one pass of GenWire or GenRod to hard-surface. Do not apply more than two layers of hard-surfacing. Peen each pass.
- Grind the ends of all stringer welds with the grain to taper 1" to 1-1/2" (25-38mm) to the parent material.

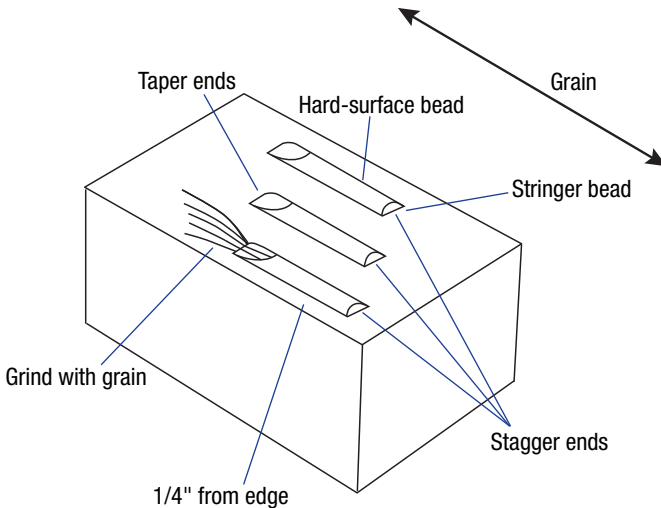

HARD-SURFACING PATTERNS

Upper Jaw

Single passes approximately 1" (25mm) apart. Begin just behind the piercing blade seats and continue toward the throat. Use three to five stringers, depending on the shear model.

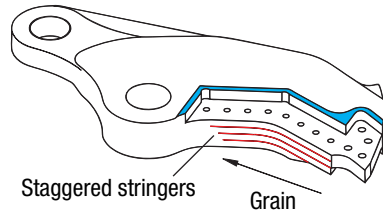

Lower Jaw

Single passes approximately 1" (25mm) apart. Work across the top of the chin plate and along the lower jaw toward the throat. Use two to three stringers, depending on the shear model.

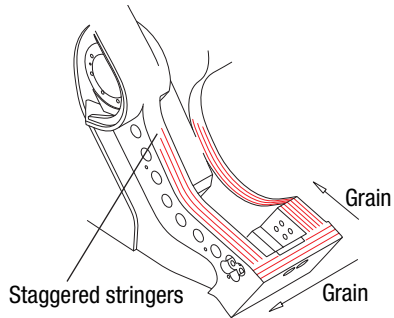

Lower Jaw Chin

Crosshatch the chin plate with stringer beads at 45° angles to form 1" (25mm) squares.

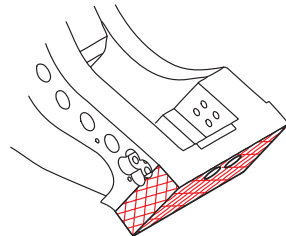

SHEAR JAW ARMOR® ROUTINE MAINTENANCE

At the 4- and 8-hour maintenance intervals, it is important to check the Shear Jaw Armor® welds for cracking and wear. Any cracked or worn thin welds need to be addressed as soon as possible to keep the plates from being torn loose, bent or lost. Cracked or worn welds should be ground or arc gouged and re-welded using E7018 stick or equivalent. Follow all weld procedures and precautions found in your GXT Safety and Operator's Manual.

Pay special attention to higher wear areas such as the top of the chin plate in front of the razor blade (Figure A), the area behind the piercing tips on the bottom of the upper jaw (Figure B) and the inside corner where the chin front and top meet (Figure C), as these are areas where the welds are most subject to wear.

Following these simple instructions will greatly increase the life of the Jaw Armor and decrease your overall maintenance and downtime.

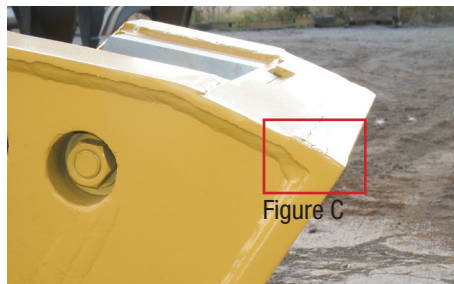
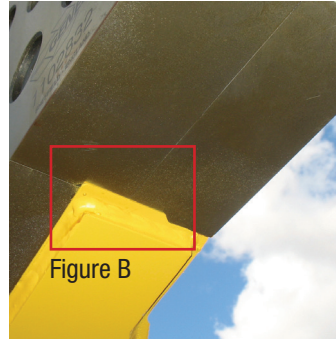
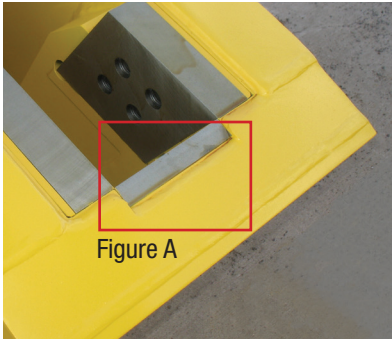

This document is a quick reference only. It does not replace the GXT Safety and Operator's Manual, which must be followed by all operators and maintenance personnel. Information is subject to change without notice.



1000 Genesis Drive, Superior, WI 54880

888-SHEAR-IT (743-2748) – Tel: 715.395.5252 – genesisattachments.com

Patents: genesisattachments.com/patents