



GXP Mobile Shear

SAFETY, OPERATOR'S & PARTS MANUAL



CONTACT INFORMATION

Genesis Attachments

1000 Genesis Drive
Superior, WI 54880 USA

Toll Free: 888-SHEAR-IT
(888-743-2748)

Phone: 715.395.5252

E-mail:
info@genesisattachments.com

Europe/Africa/Middle East Genesis GmbH

Teramostrasse 23
87700 Memmingen, Germany

Phone: +49 83 31 9 25 98 0
Fax: +49 83 31 9 25 98 80
genesis-europe.com

E-mail:
info@genesis-europe.com

Asia Pacific Representative Office

24 Upper Serangoon View #12-28
Singapore 534205

Phone: +65 9673 9730

E-mail:
tchoo@genesisattachments.com

Central America & Colombia

Cra 13A #89-38 / Ofi 613
Bogota, Colombia

Phone: +57 1 610 8160 / 795 8747

E-mail:
contact@themsagroup.com

View and download all manuals: genesisattachments.com/manuals
Patents: genesisattachments.com/products/patents

PREFACE

To ensure years of safe, dependable service, only trained and authorized persons should operate and service your Genesis attachment. It is the responsibility of the product's owner to ensure the operator is trained in the safe operation of the product and has available this manual for review. It is the responsibility of the operator and maintenance personnel to read, fully understand and follow all operational and safety-related instructions in this manual. The attachment should not be operated until you have read and fully understand these instructions. Always use good safety practices to protect yourself and those around you.

Important

This operator's manual must accompany the attachment at all times and be readily available to the operator.

Manual Replacement

Should this manual become damaged or lost or if additional copies are required, immediately contact any authorized Genesis dealer or the Genesis Service Department at 888-743-2748 or 715-395-5252 for a replacement.

Registration Form

The Warranty Registration Form must be filled out by the dealer or customer and returned to Genesis indicating the date the attachment went into service.

Possible Variations

Genesis cannot anticipate every possible circumstance that might involve a potential hazard as the owner's requirements and equipment may vary. Therefore, the warnings in this publication and on the product may not be all-inclusive, and you must satisfy yourself that the procedure, application, work method or operating technique is safe for you and others before operating.

Public Notice

Genesis reserves the right to make changes and improvements to its products and technical literature at any time without public notice or obligation. Genesis also reserves the right to discontinue manufacturing any product at its discretion at any time.

Warranty

All work or repairs to be considered for warranty reimbursement must be pre-authorized by the Genesis Service Department. Any alterations, modifications or repairs performed before authorization by the Genesis Service Department will render all warranty reimbursement consideration null and void without exception. See page 64 for Warranty Claim Procedures.

Improper operation or improperly performed maintenance may render any warranty null and void.

TABLE OF CONTENTS

CONTACT INFORMATION	2
PREFACE	3
Important.....	3
Manual Replacement.....	3
Registration Form.....	3
Possible Variations.....	3
Public Notice.....	3
Warranty.....	3
SAFETY STATEMENTS	7
OPERATIONAL SAFETY	8
Read Manual Before Operating or Maintaining the Attachment.....	8
Personal Protection.....	8
Know Your Equipment.....	8
Before Operating.....	8
Check the Equipment.....	9
Stability.....	9
Know the Work Area.....	10
Starting Procedure.....	10
Place the Load Safely.....	10
Safely Operate Equipment.....	11
Transporting the Attachment.....	12
Equipment Condition.....	12
Working Overhead.....	12
Power Lines.....	12
Use Care with Hydraulic Fluid Pressure.....	13
Prioritized Oil Flow.....	14
Emergency Situations.....	14
Unsafe Conditions.....	14
Crystalline Silica Dust.....	14
Prop. 65 Warning for California Residents.....	14
Process Material Safely.....	15
Lift the Load Safely.....	15
Place the Load Safely.....	15
 SHEAR NOMENCLATURE	16
 SHEAR INSTALLATION	18
Dual-Pump Flow.....	18
Installation Procedure.....	18
 ROTATOR INSTALLATION	20
Rotation Motor Options.....	20
Rotation Circuit - Accumulator.....	21
Rotation Circuit - Control Valve in Shear.....	22
Foot Switch Installation.....	22
Rotation Circuit - Gear Pump - Gear Type Motor.....	23
Rotation Circuit - Gear Pump - Piston Type Motor.....	23
Rotation Circuit - Auxiliary Valve on Machine - Gear Type Motor.....	24
Rotation Circuit - Auxiliary Valve on Machine - Piston Type Motor.....	24
Rotation Circuit - Piston Type Motor - Anti-cavitation Check Valve Kit.....	25
 HYDRAULIC START-UP	26
Start-up Procedure.....	26
 GENERAL OPERATION INSTRUCTIONS	27
Start-up.....	27
Efficient and Productive Operation.....	27
 COMMON OPERATIONAL CONCERNS	28
Cutting Larger Materials.....	28
Chatter While Cutting.....	28

TABLE OF CONTENTS

MAINTENANCE SAFETY	29
MAINTENANCE SCHEDULE	31
Scheduled Maintenance.....	31
Four-Hour Checklist.....	32
Eight-Hour Checklist.....	32
LUBRICATION POINTS	33
BLADE MAINTENANCE	34
Blade Bolts.....	34
AUTOGUIDE	35
AutoGuide Adjustment Procedure.....	35
PIERCING BLADES	36
Replacement.....	38
GUIDE BLADES	39
Shimming.....	39
Rotation.....	40
Replacement.....	40
Adjustment Plates.....	40
PRIMARY AND SECONDARY BLADES	41
Removal.....	41
Adjustment Plates.....	42
Rotation.....	42
Blade Gap.....	43
Blade Gap Measuring Procedure.....	43
Shimming.....	43
RAZOR BLADE	44
GENERAL WELDING GUIDELINES	45
Welding Ground Clamp.....	45
Welding Rules.....	45
BUILD-UP	46
HARD-SURFACING	47
HARD-SURFACING PATTERNS	48
HYDRAULIC/ROTATION MAINTENANCE	49
Hydraulic Requirements.....	49
Rotation Valve Input.....	49
Rotation Valve Settings.....	49
GenFlow Regeneration Valve.....	50
Regeneration Valve Adjustment.....	50
REGENERATION VALVE ADJUSTMENT	51
Adjustment Procedure 1.....	51
Adjustment Procedure 2.....	51
GENFLOW REGENERATION VALVE - HOW IT WORKS	52
Valve 6300830.....	53
SLEWING RING MAINTENANCE	54
GEARBOX MAINTENANCE	55
Planetary Gearbox Lubrication.....	55
Gearbox Lube Change-out Procedure.....	55

TABLE OF CONTENTS

ROTATION CIRCUIT	56
Rotation with Crossover Relief Valve	57
Rotation with Motion Control Valve	57
Flow Divider Rotation	58
Accumulator Valve Rotation	59
Gear Pump Rotation	60
TROUBLE-SHOOTING GUIDE	61
WARRANTY	64
Claim Procedure	64
Blade Warranty	64
PARTS ORDER POLICY AND PROCEDURE	65
Parts Orders Should Include	65
Placing Orders	65
Part Numbers	65
Shipping	65
Invoices	65
Returns	65
Warranty Returns	65
PARTS ORDER FORM	66
PARTS	67
Non-Rotating Bracket	68
Rotating Bracket / Upper Head	69
Third-Member Mount / Upper Head	70
Single Guide Blade - Blades and Wear Parts	71
Single Guide Blade - Blades and Wear Parts	72
Dual Guide Blade - Blades and Wear Parts	73
Dual Guide Blade - Blades and Wear Parts	74
Pivot Group and AutoGuide	75
Cylinder Assembly	76
Rotation Drive System	77
BOLT TORQUE SPECIFICATIONS	79
THREAD TREATMENT DIAGRAM	80
Mobile Shears	80
PROCEDURES	81
Cleaning	81
Threadlocker	81
Anti-Seize	82
No Thread Treatment	82
BOLT TORQUE SPECIFICATIONS	83
Dry Torque Values	83
Wet Torque Values	83
O-RING BOSS & FLAT FACE O-RING TORQUE SPECIFICATIONS	84
BOLT DRIVE SPECIFICATIONS	85
TOOL LIST	86
CONTACT INFORMATION	87

SAFETY STATEMENTS



This symbol by itself or used with a safety signal word throughout this manual is used to call attention to instructions involving your personal safety or the safety of others. Failure to follow these instructions can result in injury or death.



This statement is used where serious injury or death will result if the instructions are not followed properly.



This statement is used where serious injury or death could result if the instructions are not followed properly.



This statement is used where minor or moderate injury could result if the instructions are not followed properly.

NOTICE

This statement is used where property damage could result if the instructions are not followed properly.

OPERATIONAL SAFETY

Read Manual Before Operating or Maintaining the Attachment



Read this manual before attempting to operate the attachment. This operator's manual should be regarded as part of the attachment. For proper installation, operation and maintenance of the attachment, operators and maintenance personnel must read this manual.



WARNING

Serious injury or death could result if appropriate protective clothing and safety devices are not used.

Personal Protection

Use protective clothing and safety devices appropriate for the working conditions. These may include but are not limited to:

- ✓ Hard hat
- ✓ Safety glasses, goggles or face shield
- ✓ Hearing protection
- ✓ Safety shoes
- ✓ Heavy gloves
- ✓ Reflective clothing
- ✓ Respirator or filter mask



Safety matters

Know Your Equipment



Know your attachment's capabilities, dimensions and functions before operating. Inspect your attachment before operating and never operate an attachment that is not in proper working order. Remove and replace any damaged or worn parts.

Before Operating

- ✓ Warn all others in the area that you are about to start operation.
- ✓ Perform the Check the Equipment steps outlined in this manual.
- ✓ Check underneath and around the machine. Make sure all personnel and equipment are clear from the area of operation and equipment movement. Check clearances in all directions, including overhead.
- ✓ Be properly seated in the operator's seat.
- ✓ Do not attempt to operate until you have read and fully understand this manual and the OEM manual for the carrier.

OPERATIONAL SAFETY

Check the Equipment

Before use, check the equipment to ensure it is in good operating condition.

Check the following:

- ✓ Grease fittings. Pump grease at all fitting locations, see page 33.
- ✓ Hydraulic fluid level. Add hydraulic fluid as required.
- ✓ Hydraulic hoses and hose connections for wear or leaks. Repair or replace any damaged hoses or connections.
- ✓ All control levers for proper operation.
- ✓ Rotation bearing. Visually check for loose or damaged bolts. If repair is required, refer to qualified personnel.
- ✓ Grease rotation bearing and pinion gear.
- ✓ Check for loose or missing pin retaining bolts.
- ✓ Check cylinders for dents (barrel) or dings (rod).



**GOOD
CONDITION**



WARNING

Serious injury or death could result if warnings or instructions regarding carrier stability and the work area are not followed properly.

Stability

Your Genesis attachment is sized for carrier stability. However, improper operation, faulty maintenance or unauthorized modifications may cause instability.

- ✓ Know the working ranges and capacities of the carrier to avoid tipping.
- ✓ Use the recommended carrier counter weight.

The following conditions affect stability:

- Ground conditions
- Grade
- Weight of attachment
- Contents of attachment
- Operator judgement



For greater stability, knuckle the attachment to bring the load closer to the center of rotation (center of gravity) while lifting. Use extra caution during reaching to avoid tipping.

OPERATIONAL SAFETY

Know the Work Area

Check clearances in the work area. Keep all bystanders at a safe distance. Do not work under obstacles. Always check your location for overhead and buried power lines or other utilities before operation.

Check ground conditions. Avoid unstable or slippery areas. Position the carrier on firm level ground. If level ground is not possible, position the carrier to use the attachment to the front or back of the carrier. Avoid working over the side of the carrier.

To reduce the risk of tipping and slipping, never park on a grade exceeding 10% (one-foot rise over the span of a ten-foot run).

Starting Procedure

Before operating, walk completely around the equipment to make certain no one is under it, on it or close to it. Keep all bystanders at least 75 feet away from the area of operation and equipment movement. Let all other workers and bystanders know you are preparing to start. DO NOT operate until everyone is clear.

Always be properly seated in the operator's seat before operating any carrier controls.

To start:

- ✓ Make sure all controls are in the center (neutral) position.
- ✓ Be properly seated.
- ✓ Slowly operate all functions to check for proper operation and to bleed air from the hydraulic system.

To shut down:

- ✓ Return your Genesis attachment to a rest position on the ground.
- ✓ Shut off the carrier engine.
- ✓ Work controls in all directions to relieve hydraulic pressure, per excavator manufacturer's instructions.



WARNING

Serious injury or death could result if warnings or instructions regarding safe operation are not followed properly.

Place the Load Safely

Do not move the attachment, or anything held in the jaws, over people, equipment or buildings. Do not throw or drop the contents. Operate the controls smoothly and gradually.

OPERATIONAL SAFETY

Safely Operate Equipment

Do not operate equipment until you are trained by a qualified operator in its use and capabilities.

See your carrier's manual for these instructions.

- ✓ Operate only from the operator's seat. Check the seat belt daily and replace if frayed or damaged.
- ✓ Do not operate this or any other equipment under the influence of drugs or alcohol. If you are taking prescription medication or over-the-counter drugs ask your medical provider whether you can safely operate equipment.
- ✓ Never leave equipment unattended with the engine running or with the attachment in a raised position. Apply the brakes before exiting the equipment.
- ✓ Do not exceed the lifting capacity of your carrier.
- ✓ Avoid conditions that can lead to tipping. The carrier can tip when operated on hills, ridges, banks and slopes. Avoid operating across a slope which could cause the carrier to overturn.
- ✓ Reduce speed when driving over rough terrain, on a slope, or when turning to avoid overturning the carrier.
- ✓ Never use the attachment as a work platform or personnel carrier.
- ✓ Keep all step plates, grab bars, pedals and controls free of dirt, grease, debris and oil.
- ✓ Never allow anyone to be around the equipment when it is operating.
- ✓ Do not operate poorly maintained or otherwise faulty equipment. Inform the proper authority and DO NOT resume operation until the problem has been fixed.
- ✓ Do not alter or remove any safety features.
- ✓ Know your work site safety rules as well as traffic rules and flow. When in doubt on any safety issue, contact your supervisor or safety coordinator for an explanation.
- ✓ A heavy load can cause equipment instability. Use extreme care during travel. Slow down on turns and watch out for bumps. The equipment may need additional counter-weights to counterbalance the weight of the attachment.



OPERATIONAL SAFETY

Transporting the Attachment

- ✓ Travel only with the attachment in a safe transport position to prevent uncontrolled movement. Drive slowly over rough ground and on slopes.
- ✓ When driving on public roads use safety lights, reflectors, Slow Moving Vehicle signs, etc., to prevent accidents. Check local government regulations that may affect you.
- ✓ Do not drive close to ditches, excavations, etc., as cave-in could result.
- ✓ Do not smoke when refueling the prime mover. Allow room in the fuel tank for expansion. Wipe up any spilled fuel. Secure cap tightly when done.

Equipment Condition

Never operate poorly maintained equipment. When maintenance is required, repair or replace parts immediately.



WARNING

Serious injury or death could result if warnings or instructions regarding working overhead are not followed properly.

Working Overhead

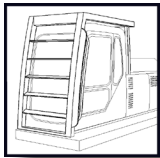

Avoid handling material overhead whenever possible. Safety glass and wire mesh cab guarding must be installed to protect the operator from flying debris that may be created during handling. Falling Object Protection Structures, or FOPS, are necessary for any application where material is to be handled overhead.



DANGER

Serious injury or death will result if warnings or instructions regarding power lines are not followed properly.

Power Lines

Do not operate the machine near energized power lines. All local, state/provincial and federal regulations must be met before approaching power lines, overhead or underground cables, or power sources of any kind with any part of the carrier or attachment. Always contact the appropriate utility when operating near power lines. The lines should be moved, insulated, disconnected or de-energized and grounded before operating in the area.



Current in high voltage lines may arc some distance from the wire to a nearby ground. Keep all parts of the machine at least 50 feet (16m) away from power lines.

OPERATIONAL SAFETY



WARNING

Serious injury or death could result if warnings or instructions regarding hydraulic fluid pressure are not followed properly.

Use Care with Hydraulic Fluid Pressure

Hydraulic fluid under pressure can penetrate the skin and cause serious injury or death. Hydraulic leaks under pressure may not be visible.

- ✓ Keep unprotected body parts, such as face, eyes and arms as far away as possible from a suspected leak. Flesh injected with hydraulic fluid may develop gangrene or other permanent injuries.
- ✓ If injured by injected fluid see a doctor immediately.
- ✓ Wear safety glasses and protective clothing and use a piece of cardboard or wood when searching for hydraulic leaks.

Do Not Use Your Hands!
See illustration below.

- ✓ Hydraulic oil becomes hot during operation. Do not let hydraulic oil or components contact skin, as it could cause severe burns. Allow hydraulic components to cool before working on them. Use appropriate protective clothing and safety equipment. If burned, seek immediate medical attention.

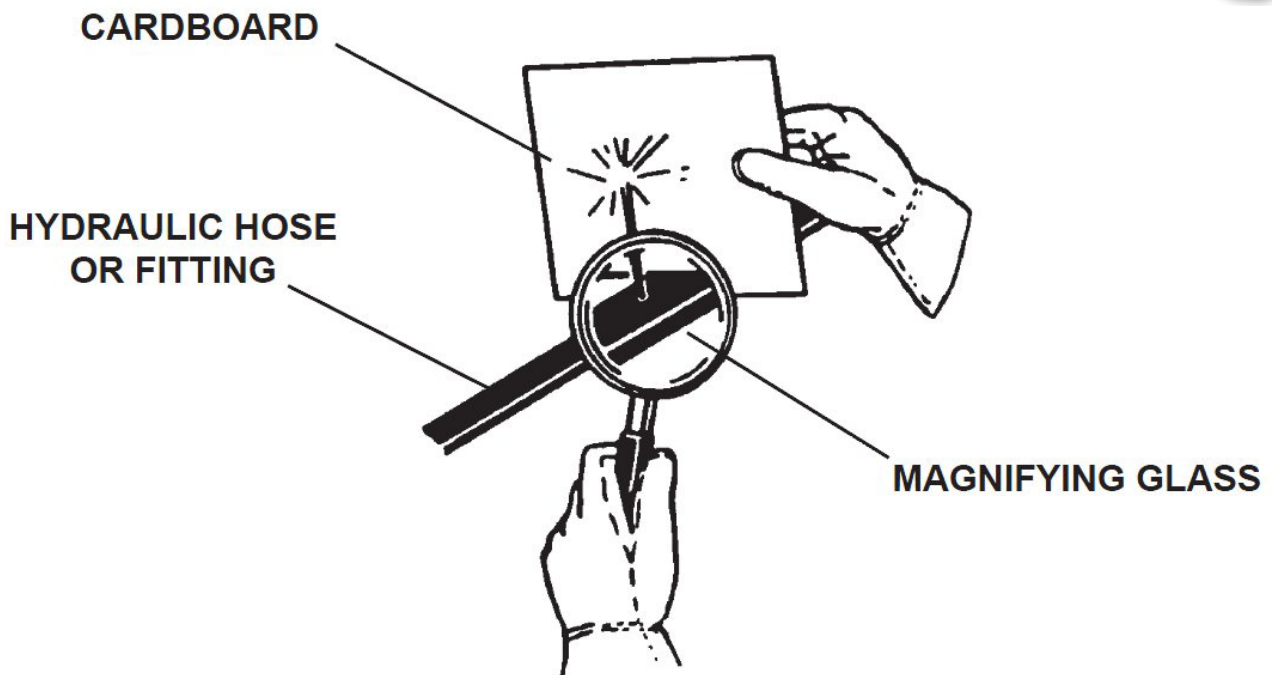
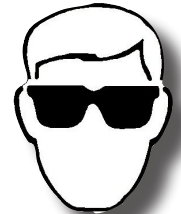

OPERATIONAL SAFETY

Prioritized Oil Flow

Equipment operators must ensure there is prioritized oil flow to the main valves in overhead operations or high reach conditions.

Emergency Situations

Always be prepared for emergencies. Make sure a fire extinguisher is available. Be familiar with its operation. Make sure to inspect and service the fire extinguisher regularly. Make sure a first aid kit is readily available.



Unsafe Conditions

Do not operate if an unsafe condition exists. Stop operation immediately, shut down the machine and report the unsafe condition to the proper authority. Equipment operation and maintenance practices directly affect your safety and the safety of those around you. Always use common sense while operating and be alert to unsafe conditions.

Crystalline Silica Dust

It is recommended to use dust suppression, dust collection and if necessary, personal protective equipment during the operation of any attachment that may cause high levels of dust.



DANGER

Exposure to respirable crystalline silica dust along with other hazardous dusts may cause serious or fatal respiratory disease.

IMPORTANT: Concrete and masonry products contain silica sand. Quartz, which is a form of silica and the most common mineral in the Earth's crust, is associated with many types of rock.

Some activities that may have silica dust present in the air include demolition, sweeping, loading, sawing, hammering, drilling or planing of rock, concrete or masonry.

It is recommended to use dust suppression (such as water) or dust collection (such as a vacuum) along with personal protective equipment if necessary during the operation of any attachment that may cause high levels of silica dust.



Prop. 65 Warning for California Residents



WARNING

This product may contain chemicals known to the State of California to cause cancer, birth defects, or other reproductive harm. For more information visit: P65Warnings.ca.gov

OPERATIONAL SAFETY



WARNING

Using your Genesis attachment in unauthorized applications may create an unsafe situation and will void the warranty.

Process Material Safely

- Do not process hardened steel material such as tool steel, railroad rail, axles or machined parts. Hardened material breaks, rather than shears, which may cause flying debris. It will also cause damaging decompression spikes to your Genesis attachment and base carrier hydraulic systems.
- Do not operate any functions of the carrier while cutting or crushing with your Genesis attachment, including boom and drive functions.
- Do not pull down structures with your Genesis attachment. Doing so may cause falling debris or material may break free and exceed the capacities of the carrier, causing a tipping hazard.
- The rotator should only be used for positioning your Genesis attachment. Do not use the rotator to pry or break material.

Lift the Load Safely

- The hydraulic system has been preset and tested by your dealer. Do not alter hydraulic settings without consulting an authorized Genesis dealer or the Genesis Service Department. Doing so will void the warranty and may cause structural damage, accidents or tipping.
- Make sure the load is held securely in the jaws. Do not move a loaded attachment if load is loose or dangling. Make sure the load is pinched between the jaws – never cradle a load.
- For greater stability, knuckle the attachment to bring the load closer to the center of rotation (center of gravity) while lifting. Use extra caution during reaching to avoid tipping.

Place the Load Safely

- Do not move the attachment, or anything held in the jaws, over people, equipment or buildings. Place the load gently. Do not throw or drop the contents.
- Operate the controls smoothly and gradually. Jerky controls are hazardous and may cause damage to the carrier.
- Avoid fire hazards. Keep the area clean. Remove all flammable materials from the area during any welding or heating process. Have a fire extinguisher nearby and know how to use it.
- Never substitute pins or bolts. Use factory supplied pins. Replace all bolts with the same size and grade. Failure to do so may cause serious injury or death.
- Use your Genesis attachment only as directed in this manual. Do not use the attachment to lift and move other objects. Doing so may cause instability and tipping.

SHEAR NOMENCLATURE

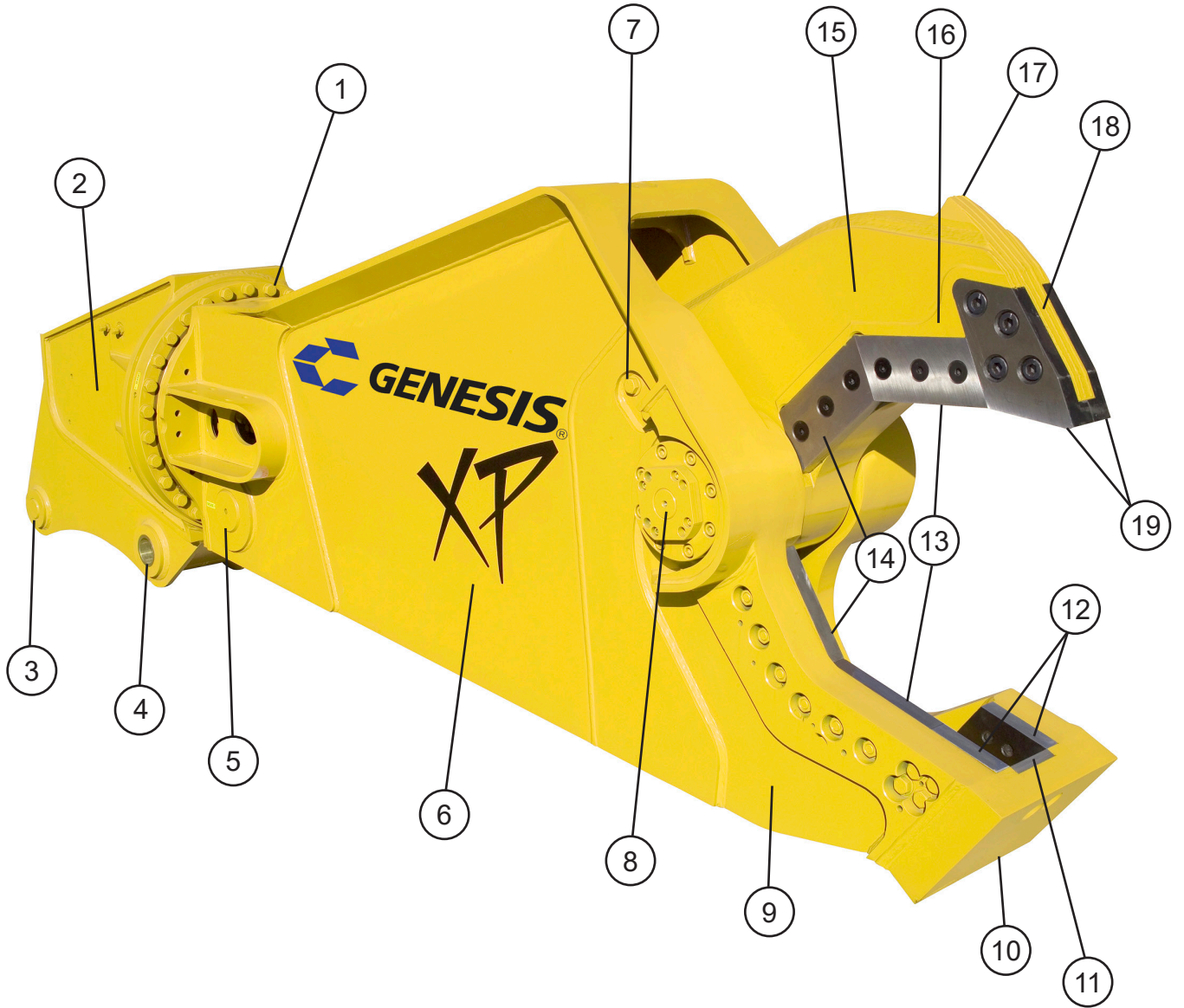

SHEAR NOMENCLATURE

1	Slewing Ring	Connects the shear head to the shear stick or body. Not used on straight shears.
2	Shear Sub-Head	Houses and protects the hydraulic components used for 360° rotation.
3	Stick-Pin Connection	Cylinder pin connection
4	Boom Pivot Connection	
5	Rear Cylinder Pin	Main cylinder
6	Shear Stick or Body	Houses and protects the main hydraulic cylinder.
7	AutoGuide or Puck	See the Genesis Fastener Manual for torque value.
8	Pivot Group	Includes the end cap, tie rod and tie rod nut.
9	Lower Shear Jaw	
10	Chin	Keep top edge built up, maintain radii in razor blade pocket after build-up and hard-surfacing.
11	Razor Blade	NEVER insert shims behind.
12	Guide Blades	Insert shims between the adjustment plate and blade when setting/adjusting blade gap. Note: From the operator's view, the left guide blade may or may not have an adjustment plate. If not, insert shim(s) directly against the back of the guide blade.
13	Secondary Blades	Upper and lower cutting blades. Only insert shims behind the lower, placing between the adjustment plate and blade when setting/adjusting blade gap.
14	Primary Blades	Upper and lower cutting blades. Only insert shims behind the lower, placing between the adjustment plate and blade when setting/adjusting blade gap.
15	Upper Shear Jaw	Never shim blades in upper jaw.
16	Protection Strips	Raised areas of parent material along the blade pockets on upper and lower jaws should be flush to 0.010" below the blade faces.
17	Rhino Horn	
18	Tang	Parent material between the piercing blades
19	Piercing Blades	NEVER insert shims behind.

SHEAR INSTALLATION

Preparation of the excavator prior to shear delivery will make installation safer and easier. Contact Genesis or your Genesis dealer for assistance.

Dual-Pump Flow

Typically, an excavator has two hydraulic pumps supplying oil to the main valves of the excavator. The main valves usually are separated into two halves. Tying two circuits from opposite sides of the valve is called summing – basically achieving dual-pump flow to operate one system. This is the preferred method of achieving maximum speed to a shear. This may also be achieved by interchanging the stick and bucket circuits.

Usually a bucket circuit is single-pump flow and a stick circuit is dual-pump flow. At times, adding an auxiliary circuit spool to the stick circuit helps reduce back-pressure in the system and speed up jaw open and close.

In certain cases, the bucket and auxiliary circuits can be summated to achieve dual-pump flow, depending on whether the bucket and auxiliary are on separate sides of the main valve and whether the auxiliary circuit can be proportionally controlled by teeing into the bucket pilot control circuit. The auxiliary circuit must also be capable of proportionally controlling pump initiation on the auxiliary side of the circuit. On many excavators, the auxiliary circuit is controlled by percentage of flow set in the computer. This may not control the speed that the pump's compensator strokes up, but turns the circuit instantly on or off. Because shears take all the flow the pumps can give them, the computer signals the pump to instantly turn on or off, instead of gradually ramping up or down, which can cause sharp, damaging spikes in the hydraulic circuit.

Installation Procedure

Note: The shear is usually shipped in an upright position. Extreme care must be used when inverting the shear for installation.

Remove bucket or other stick attachments, following the excavator OEM's removal and safety instructions.



WARNING

Removing any connecting pin may be hazardous. To remove a connecting pin, position the shear on the ground and properly support.



WARNING

Particles may fly when a pin is struck. Use a drift pin or mallet when striking pins. Keep all personnel at a safe distance.

SHEAR INSTALLATION



Be sure hydraulic pressure is relieved before disconnecting hydraulic fittings. Remove necessary fittings SLOWLY.

The attachment is usually shipped in an upright position. Extreme care must be used when inverting the attachment for installation.

Follow the excavator OEM's removal and safety instructions to remove the bucket or other stick attachments.

Position the attachment upside down on flat, solid ground. Blocking may be required to raise the mounting bracket into proper position.

Track the excavator to the attachment with the jaws facing the operator. Lift the excavator stick over the attachment, carefully positioning the stick tip connection with the attachment mounting main pivot bore. Pin the excavator stick to the attachment.

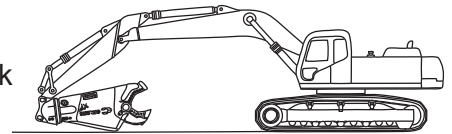

Slowly raise the boom to lift the attachment, allowing the cylinder pivot connection to come within range of the excavator cylinder stroke.

Extend the excavator cylinder until the power link bore lines up with the cylinder pivot connection. Pin the excavator cylinder to the attachment.

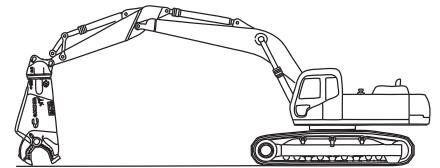

Crowd and extend the attachment, checking closely to make sure there is no interference between the bracket and hard lines. Also check for interference between the cylinder and boom/stick.

Install excavator hydraulic hoses, supply and return, from the stick tip to the attachment manifold blocks.

The stick and bucket circuits are oriented as to rod and bore sides of their respective cylinders. Be sure to connect rod-to-rod and bore-to-bore when connecting a circuit to the attachment. When these are reversed, extra pressure is needed to open the jaw, which pulls down the engine, de-strokes the pumps, increases jaw cycle time, creates high oil temperature and burns more fuel.

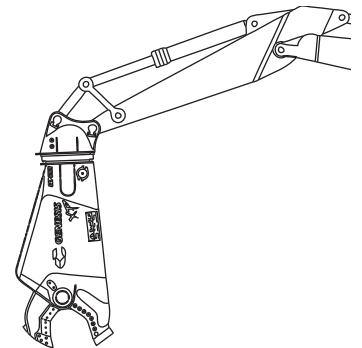

The attachment must be vertical before putting oil into it or an air lock in the regen valve may prevent the jaw from opening.

Note: Genesis' standard pin material is Induction Hardened Chrome (IHC), which is to be used for all direct pin 2nd and 3rd member mounting. To avoid risk of pin failure when using a pin grabbing coupler, the standard IHC pins must be replaced with a heat-treated pin material from Genesis.



Removing any connecting pin may be hazardous. To remove a connecting pin, position the attachment on the ground and properly support. Particles may fly when a pin is struck. Use a drift pin or mallet when striking pins. Keep all personnel at a safe distance.

ROTATOR INSTALLATION

The rotator requires a 1/2" minimum case-drain line with a minimum working pressure rating of 250 PSI. **Run the case-drain line from the rotation head of the shear to a dedicated filter on the excavator, plumbed directly into the tank.**

The maximum case-drain pressure measured at the motor while attempting to rotate with the shear stalled on the ground is 80 PSI for a gear motor and 40 PSI for an axial piston motor. Gerotor type motors require no case drain. If you are unsure of your motor type, contact the Genesis parts department with the serial number of your shear. Case-drain pressures will rise during cold weather operation.

Use the correct fittings. Secure the case-drain line to the excavator stick.

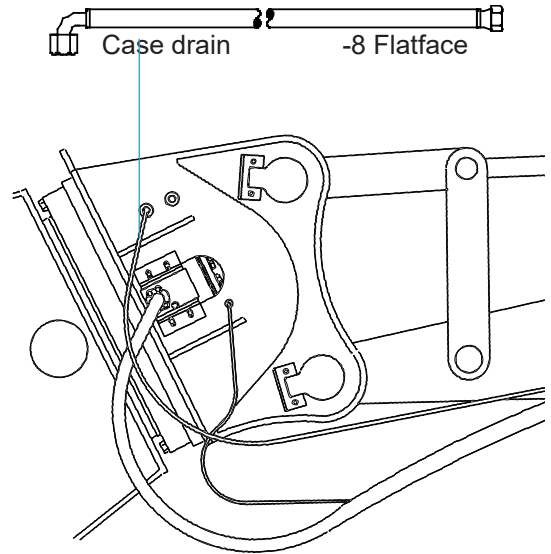

NOTICE

Do not plumb the case-drain into the main return system.

Rotation Motor Options

Gear motors are the standard motor for shear models GXP 440 and larger. This is the preferred motor for processing applications where the shear is usually working vertically, such as in scrap yards and on demolition sites where material is on the ground. These motors may slowly drift or rotate in material handling applications.

Piston motors are used in overhead demolition and material handling applications that require fine control and solid load holding capabilities. These motors are more expensive and require additional plumbing but advantageous in load holding applications.

Gerotor motors are used in the GXP 200 and 300, which are direct drive rotation system models.

All motor styles are plumbed with crossover relief valves in the rotation circuit to prevent damage to the rotation system components caused by overloading or external forces applied to the shear. Under these circumstances, the operator needs to be aware the shear will rotate until the load is decreased to the crossover relief valve settings.



Gear Motor

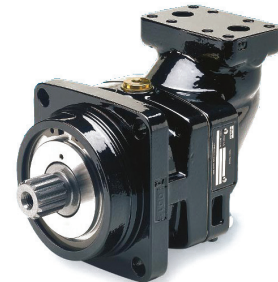

Piston Motor



Gerotor Motor (200/300)

Rotation Circuit - Accumulator

Motor Case Drain

WARNING: Do not exceed 80 PSI while operating Gear Type Motor (40 PSI for Piston Type Motor)

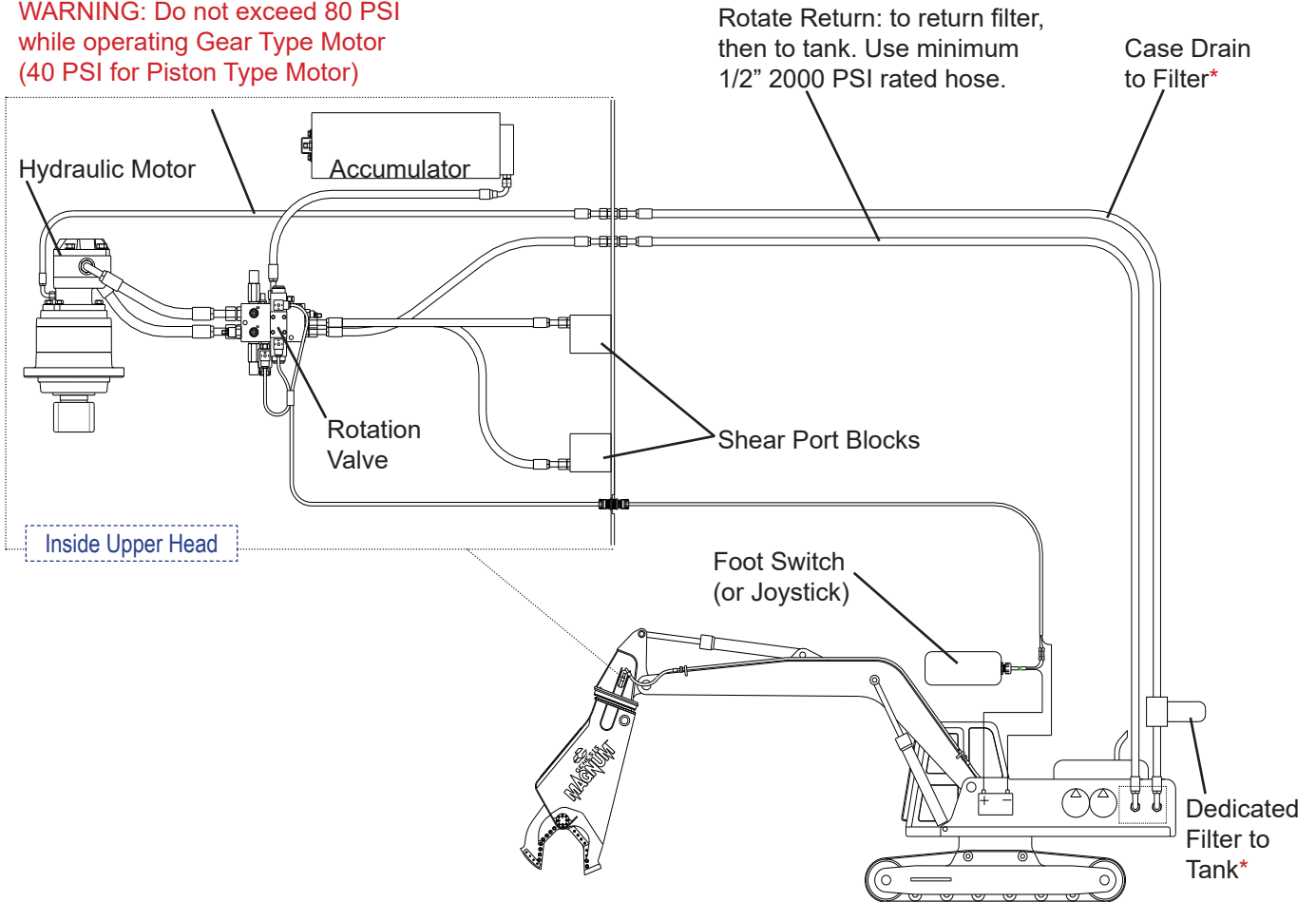

***Note:** Do not connect filter to any other return circuits, only to hydraulic tank.

Rotation Circuit - Control Valve in Shear

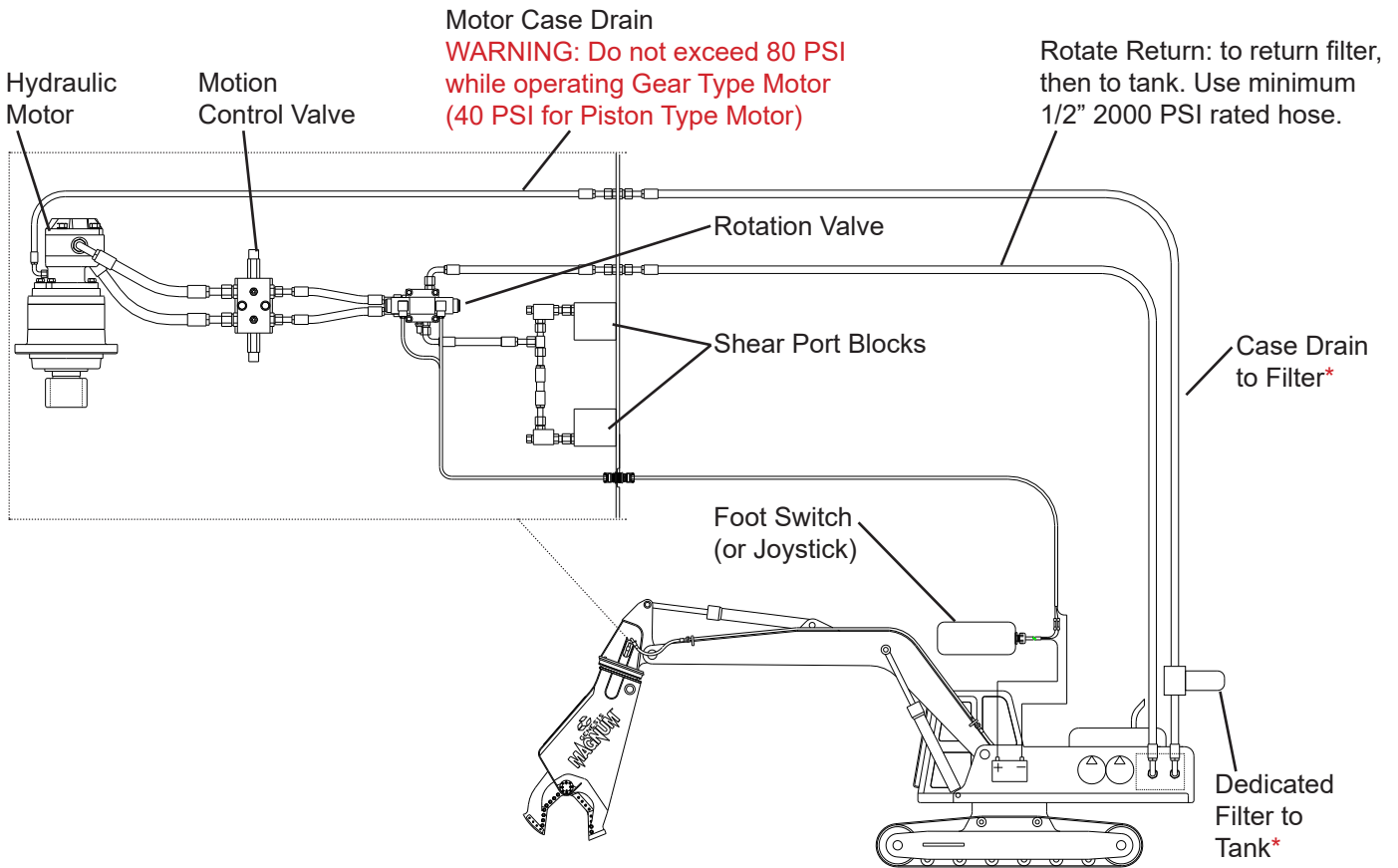

*Note: Do not connect filter to any other return circuits, only to hydraulic tank.

Foot Switch Installation

Install the foot switch in the excavator and connect with electrical harness. Consult excavator dealer when using an alternate to the Genesis-supplied foot switch.

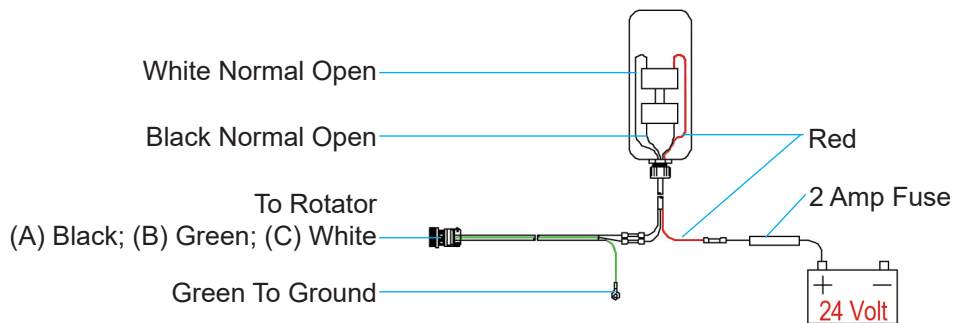

The rotators on the following pages require an additional hydraulic circuit. One of the several available options has been supplied with the shear. The diagrams show the installation of the additional circuit. Refer to the Hydraulic/Rotation Maintenance section of this manual for valve descriptions, functions and settings.

Rotation Circuit - Gear Pump - Gear Type Motor

Motor Case Drain
WARNING: Do not exceed 80 PSI while operating

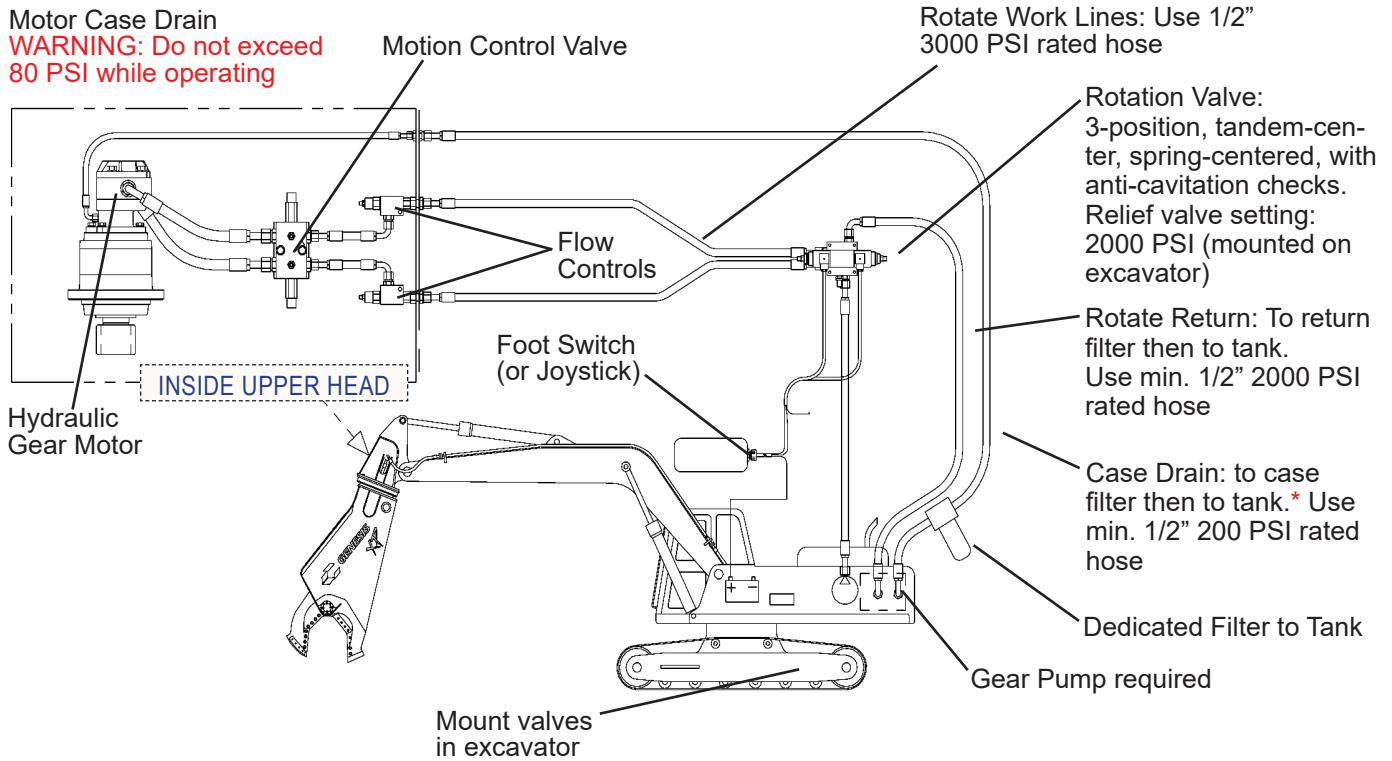

Rotation Circuit - Gear Pump - Piston Type Motor

Motor Case Drain
WARNING: Do not exceed 40 PSI while operating

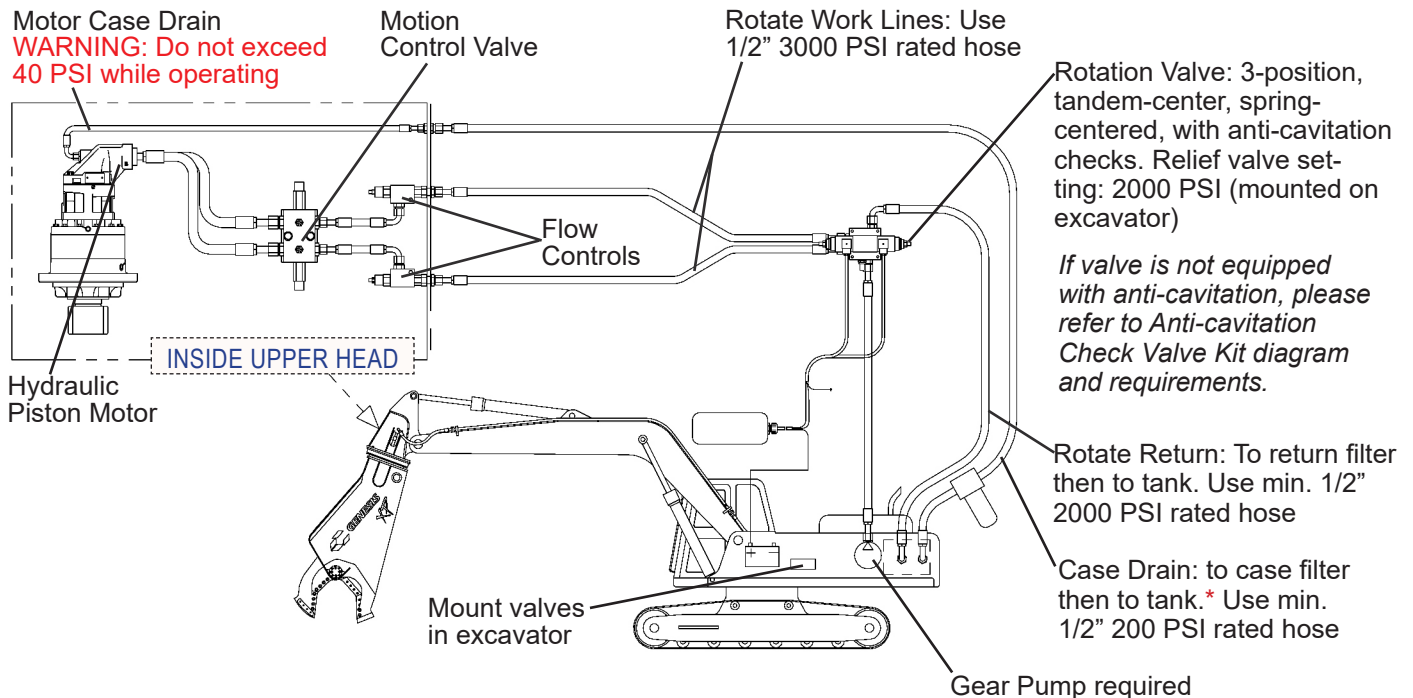

*Note on both Gear and Piston Type motors: Do not connect filter to any other return circuits, only to hydraulic tank.

Rotation Circuit - Auxiliary Valve on Machine - Gear Type Motor

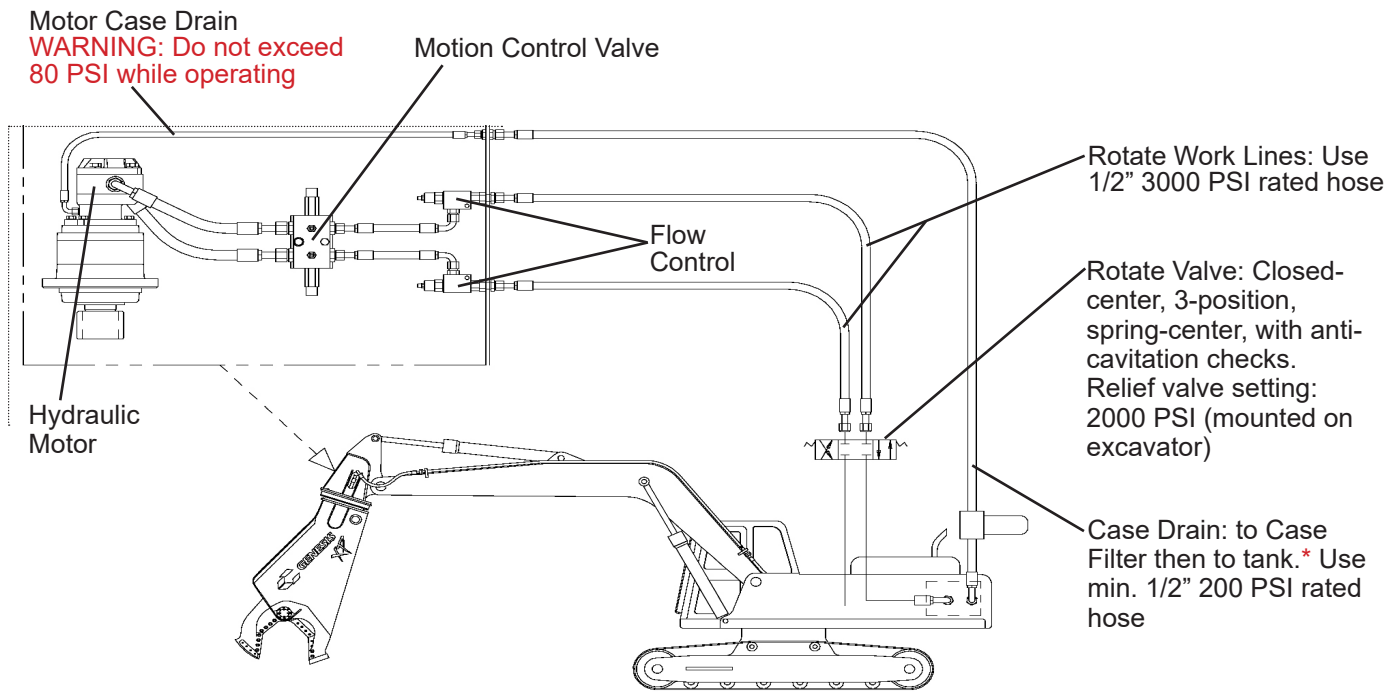

Rotation Circuit - Auxiliary Valve on Machine - Piston Type Motor

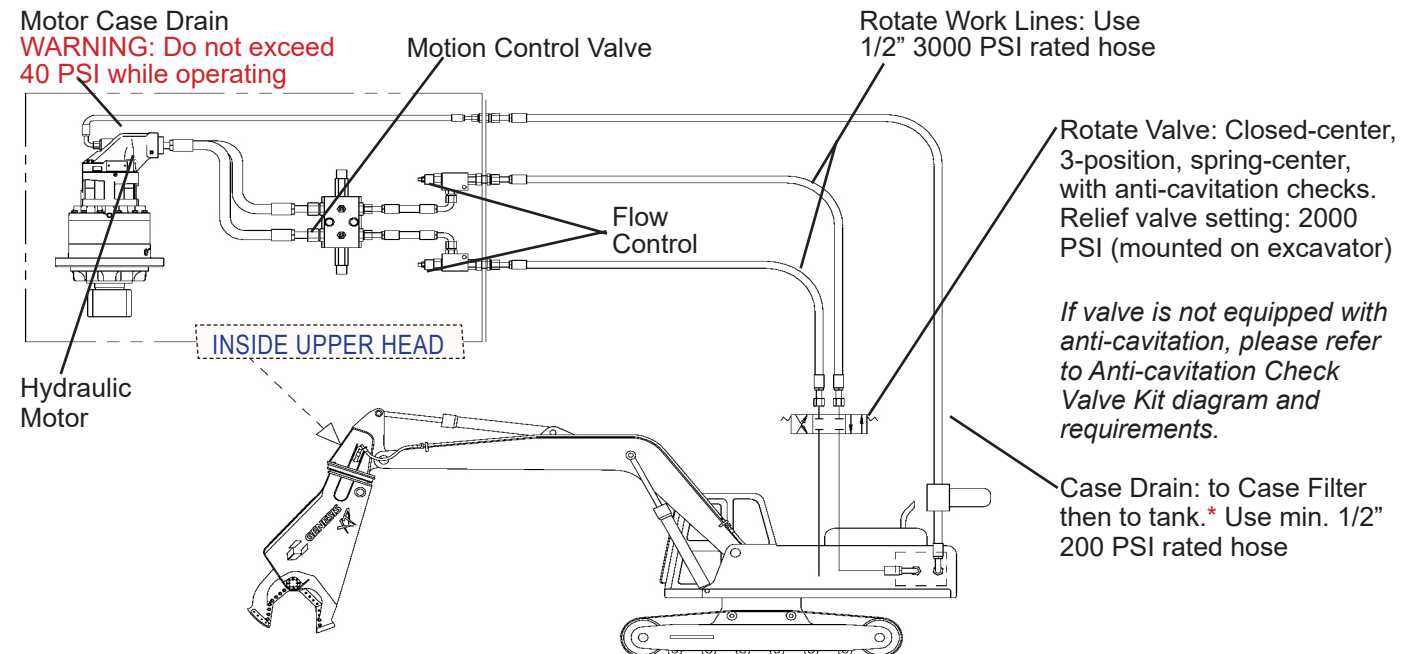

Note on both Gear and Piston Type motors: Do not connect filter to any other return circuits, only to hydraulic tank.

Rotation Circuit - Piston Type Motor - Anti-cavitation Check Valve Kit
(Part #5410014)

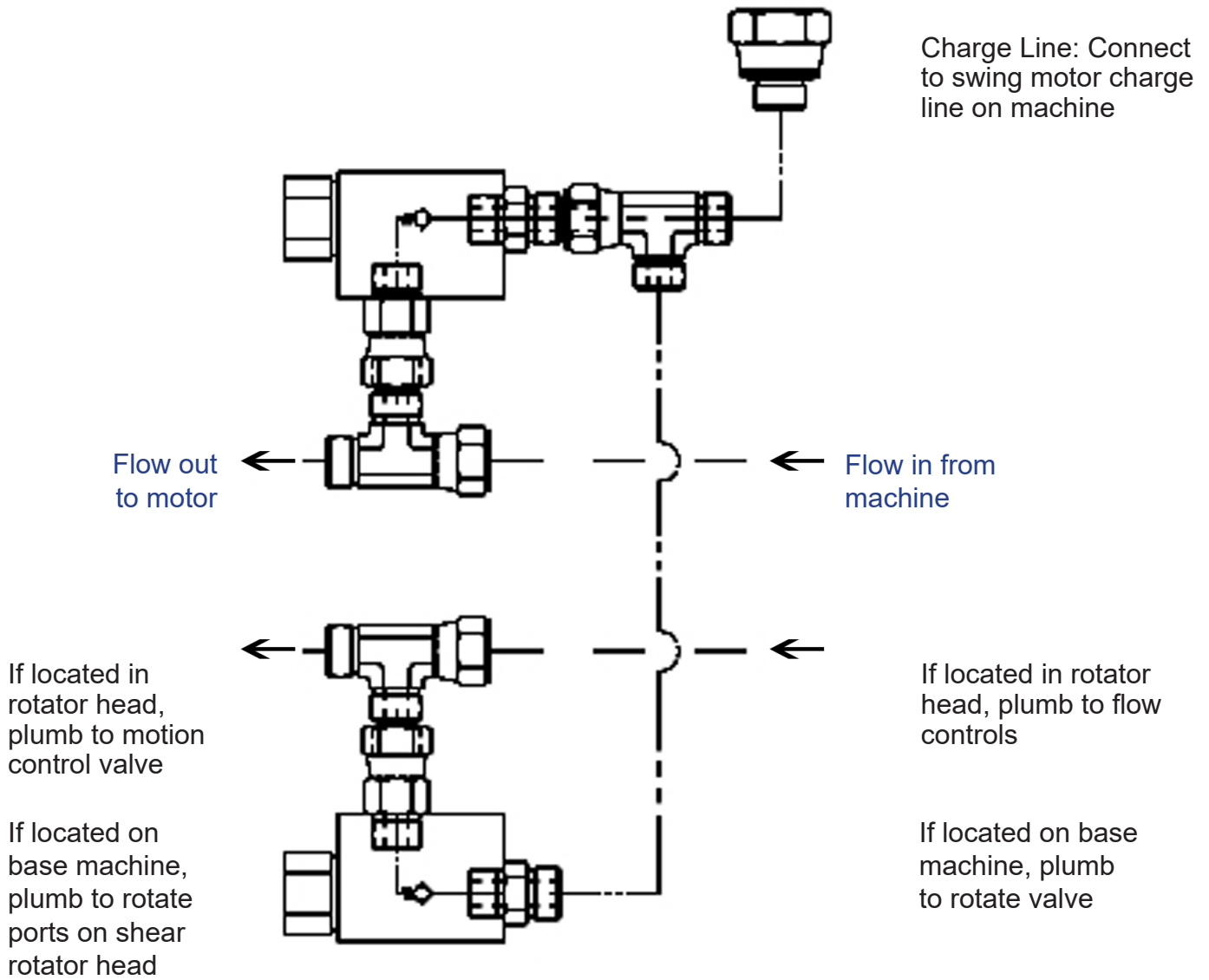

HYDRAULIC START-UP

Genesis shears are designed to operate under full excavator pressure or up to 5500 PSI. Due to these high pressures, it is important that air is bled from the shear cylinder after installation. Failure to follow these procedures could result in cylinder seal damage and/or excavator hydraulic system damage.

Start-up Procedure

- ✓ Check the excavator hydraulic tank for proper fluid level.
- ✓ Excavator oil should be warmed up before hooking up shear lines in cold weather. If oil is cold, air from the cylinder will be pushed into the oil tank, causing oil to foam. This problem takes hours to correct, and it may cause pump cavitation.
- ✓ Follow the OEM procedures for starting and warming the excavator hydraulic system. Do not operate the shear circuit during the warm-up period.
- ✓ After the excavator has reached normal operating temperature, set the engine to idle speed.
- ✓ Shear must be vertical. Do not allow the tank to run low - have someone watch the oil gauge.
- ✓ Slowly fill the bore end of the shear cylinder to partially close the jaws.

NOTICE

Do not fully extend or retract shear cylinder with the first cycles.

- ✓ Slowly fill the rod end of the shear cylinder to open the jaws. Use partial strokes extending and retracting, slowly working to full strokes.
- ✓ Stop and check the excavator hydraulic fluid level again to be sure there is still sufficient fluid. Service as required. Note: hydraulic fluid level should be checked with the shear jaws open (cylinder retracted).
- ✓ Cycle the shear jaws five or six strokes before increasing to full operating pressure.

GENERAL OPERATION INSTRUCTIONS

Follow all rules and procedures outlined in the Operation Safety section of this manual.

Use the shear only as intended, in approved applications, as set forth in this manual.

Do not allow shear, exposed cylinder rod or hoses to come into contact with any obstacles, buildings or the excavator.

The shear is not intended to crush or break objects or structures by swinging or dropping the shear.

Start-up

During initial operation and any time jaw maintenance has been performed, process thin and lighter material first to work-harden wear areas, developing a harder, more durable edge. This is also the most effective time to process materials such as sheet metal or wire. The new or repaired edges will cut more efficiently and be less likely to jam material between the blades.

NOTICE

When operating in temperatures below freezing, it is also important to process light materials first. This allows the shear's structural material to warm up, preventing thermal cracking.

Efficient and Productive Operation

Operators should become accustomed to performing work in the most proficient manner possible.

When cutting, build up and cut out of small piles, keeping the surfaces of the shear chin plate and upper jaw out of the dirt as much as possible. Dirt is much more abrasive than steel and needlessly increases build-up and hard-surfacing time and intervals.

It also helps to give yourself enough room to keep out of the way of other personnel and machines. Material should be picked from a pile and swung to the side and cut in a new area. This prevents redundant cutting of the same pieces and allows for the newly prepared material to be loaded out with another material handling machine.

Material processing areas should be as close as safely possible to the location for loading materials for transportation. Less time spent processing, loading and transporting materials greatly affects operational costs and productivity and dramatically reduces man hours, fuel costs and wear on equipment.

Operators should develop the habit of assessing materials to be processed and visualizing a starting and finishing point to use the fewest cuts possible. Excessive moving, positioning and handling cost time and money. Bringing the jaws to full open, when only partial jaw open is needed for a cut, wastes time and fuel, slows other excavator functions as well as causes needless wear to hydraulic components, hoses and o-rings. More efficient processing will extend the life of the attachment.

COMMON OPERATIONAL CONCERNS

Cutting Larger Materials

When cutting larger materials the shear jaw stalls just before cutting.

Suspend the material on the prepared pile, open the jaw and position the material as close to the throat as possible. Without pushing down on the material with excavator force, rapidly close the jaw on the material. Using the speed of regeneration can improve performance when cutting larger materials.

Chatter While Cutting

If the shear starts to chatter while cutting, back out of the cut and reposition at a different spot.

Chattering is an indication that material is jamming between the piercing blades and guide blades or between the upper and lower cutting blades. This indicates that blade maintenance needs to be performed immediately. Worn blades and improper blade gaps are usually the cause.

Insufficient piercing blade gaps will also cause this, as the blades and parent material of the jaws are subject to thermal expansion from cutting friction. The tighter the blades run, the hotter they get and the more they expand. Piercing blades and guide blades are the most susceptible to this and will show blue streaking on their corresponding faces. In some cases, they will get so hot that surface cracks and spidering occur. As this happens, it will spread the lower jaw and increase gaps between the primary and secondary blades, causing thin material to jam between them.

Another key area to watch is the opening between the guide blades. Be aware of material that may get into this opening before the piercing blade moves into this space, as it will be wedged between the piercing blades and guide blades.

Most jamming conditions can be prevented if the operator pays attention to the sound and vibration that is associated with a jam. Remember that because of the rod-to-bore ratios of displacement on the shear's hydraulic cylinder piston, the shear has half the force on jaw open compared to jaw close. So if the attachment is jamming while closing, it won't have enough retract force to open.

MAINTENANCE SAFETY

Only trained and authorized persons should perform maintenance on the shear. To be qualified, you must understand the instructions in this manual, have training, and know the safety rules and regulations of the job site.

Do not alter the physical, mechanical or hydraulic operation of the shear. Doing so may cause a dangerous situation for yourself and those around you and will void the warranty.

Do not attempt repairs you do not understand. If any questions arise regarding a safety or maintenance procedure, contact Genesis or your Genesis dealer.

Read this entire manual. All personnel must understand the maintenance and safety procedures.

Use factory authorized parts. The use of unauthorized parts may compromise safety, performance and durability of the shear and may void the warranty.

Follow the daily checklist and maintenance schedules in this manual. Extreme conditions may dictate shorter maintenance intervals.

Do not exceed bolt torque specifications. See the Genesis Fastener Manual.

Do not weld on structural components without consulting Genesis. Doing so may cause structural failure and void the warranty.

Do not operate a shear without the case-drain line properly installed if the shear uses a rotation system that requires a case drain. Doing so will cause immediate failure of the rotate motor and gearbox.

Do not work on the shear before ensuring it will not move. Completely lower the boom to the ground or a rest position and relieve hydraulic pressure.

Never operate poorly maintained equipment. When maintenance is required, repair or replace parts immediately.

Do not operate under unsafe conditions. If an unsafe condition arises during operation, immediately shut down the equipment and report the situation to the proper authority.

MAINTENANCE SAFETY

Do not work on any hydraulic lines or components while they are pressurized. Escaping hydraulic fluid can penetrate the skin, causing serious injury or death. Relieve pressure before performing maintenance. Keep hands and body parts away from pin holes and nozzles, which eject fluids under high pressure. Use a piece of cardboard to search for leaks.



If fluid is injected into the skin, seek medical assistance immediately from a doctor familiar with this type of injury.

NOTICE

See “Use Care with Hydraulic Fluid Pressure”, page 13

Hydraulic oil becomes hot during operation. Do not let hydraulic oil or components contact skin, as it could cause severe burns. Allow hydraulic components to cool before working on them. Use protective clothing and safety equipment.



Remove paint before welding or heating. Hazardous fumes/dust can be generated when paint is heated by welding, soldering or using a torch. Do all work outside or in a well ventilated area and dispose of paint and solvent properly.

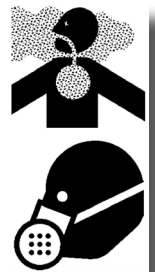

When sanding or grinding paint, avoid breathing the dust. Wear an approved respirator. If you use solvent or paint stripper, remove stripper with soap and water before welding. Remove solvent or paint stripper containers and other flammable materials from area. Allow fumes to disperse at least 15 minutes before welding or heating.

Avoid fire hazards. Keep the area clean. Remove all flammable materials from the area during any welding or heating process. Have a fire extinguisher nearby and know how to use it.



Never substitute pins or bolts. Use factory supplied pins. Replace all bolts with the same size and grade. Failure to do so may cause serious injury or death.

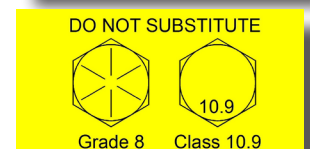

MAINTENANCE SCHEDULE

Performing scheduled maintenance will promote safe, reliable operation of your shear. Inspect and grease components every eight hours of operation, as indicated on the following checklist. Use maintenance procedures described in this manual. If you are not able to safely and competently perform these procedures, have a Genesis dealer perform them.

After the first **80 hours** of operation, check all bolts, including slewing ring bolts.

Change gearbox lube after first **50 hours** of operation.

NOTICE

Extreme operating conditions may require shortened maintenance intervals.

Operating the shear with excessively worn blades, blade gaps or main bearings could lead to premature cylinder failure. Excessive deflection of the upper jaw from these conditions will transfer side loading forces to the cylinder piston and barrel, which causes undue pressure on the wear bands of the piston, potentially resulting in cylinder failure.

Pounding the upper jaw lever arm or cylinder clevis on the ground or a hard object to clear a material jam can cause high pressure hydraulic spikes to the shear and excavator which can damage the hydraulic system components. These spikes can damage the cylinder piston seals, which will allow oil to bypass and wash out the piston wear bands, resulting in premature and possibly catastrophic system failures.

Scheduled Maintenance

- ✓ Check gearbox lube every 250 hours. Change annually.
- ✓ Replace regeneration valve components every 4000 hours.
- ✓ Reseal cylinder at 2 years or 4000 hours, whichever occurs first, the first time; 18 months or 3000 hours for all following reseals. In severe-duty applications or if operating the shear more than 10 hours per day, reduce these intervals.
- ✓ Reseal swivel every 2 years or at the time of cylinder resealing.

MAINTENANCE SCHEDULE

Four-Hour Checklist

Mid-shift, perform a brief visual check for hydraulic leaks, blade damage, and loose or missing bolts. A more thorough inspection, to be performed at the end of each shift, is described below on the eight-hour checklist.

Grease:

- Shear cylinder - end of pin
- Shear cylinder rod
- AutoGuide at fitting and smear grease on contact surface of upper jaw
- Main shaft/pivot, both sides

Grease all locations until grease extrusion is visible with jaw open and closed.

Eight-Hour Checklist

Inspect:

- Bolts - check for loose bolts, replace if damaged
- Fittings and hoses for damage or leaks
- Bracket pivot for wear and pin retainers
- Cylinder pivot for wear and pin retainers
- Entire shear for cracks (visual check)

Grease:

- Bracket pivot
- Bracket cylinder
- Bearing slewing (five locations)
- All points listed in 4-hour checklist

Grease all locations until grease extrusion is visible.

Jaws and Blades:

- Check blade gaps*
- Check blade edge radiuses*
- Check for loose or damaged bolts, re-torquing loose bolts when cool
- Check AutoGuide and shim if needed
- Build-up and hard-surface as required
- Grind off any rolled-over or mushroomed blade edges
- Shear Jaw Armor® - build-up and hard-surface as needed

* See Blade Maintenance information in this manual regarding maximum gap and radius for your specific shear model. Blade gaps should be checked and maintenance performed when the shear has cooled to ambient temperature.

LUBRICATION POINTS



Shut off excavator and disable hydraulics per OEM instructions before greasing.

For normal conditions above 32°F (0°C), use a lithium-based, premium grade 2 extreme-pressure grease. For temperatures below 32°F, use a grade 0 grease.

Do not use grease containing Molybdenum (Moly).

Genesis GLG-2[®] anti-wear, extreme-pressure lithium grease, PN 6302601, is recommended for all temperature conditions.

The shear jaws must be closed for access to all grease fittings. Grease all fittings every four to eight hours of operation (see Maintenance Schedule).

After greasing the rotation bearing, rotate the shear through two full rotations.

Grease locations:

1. Bracket pivot
2. Bracket cylinder
3. Shear cylinder butt
4. Shear cylinder rod
5. Main shaft/pivot (both sides)
6. Rotation bearing (four locations)
7. Rotation head (two locations)
8. AutoGuide
9. AutoGuide contact surface on upper jaw



Shear cylinder, AutoGuide and pivot should be greased every four hours and at the end of a shift, while the shear is warm. Bracket and rotation should be greased at the end of a shift.

BLADE MAINTENANCE

Blade and blade seat maintenance greatly affects performance. To maximize cutting performance and optimize the life of replaceable parts, follow this specific sequence of checks, adjustments and maintenance.

1. AutoGuide - shim to tolerance and replace when shims exceed 0.100".
2. Piercing Blades - replace when edges are worn.
3. Guide Blades - rotate, shim to tolerance and replace when worn.
4. Primary and Secondary Blades - rotate, shim to tolerance and replace when all edges are worn. All four blades are identical on shears featuring dual guide blades.
5. Razor Blade - rotate and replace when worn.
6. Jaw Hard-surfacing - build-up and hard-surface as needed.

Blade Bolts

Torque blade bolts every eight hours to the specifications listed in the Genesis Fastener Manual. Check for broken bolts daily and replace immediately.

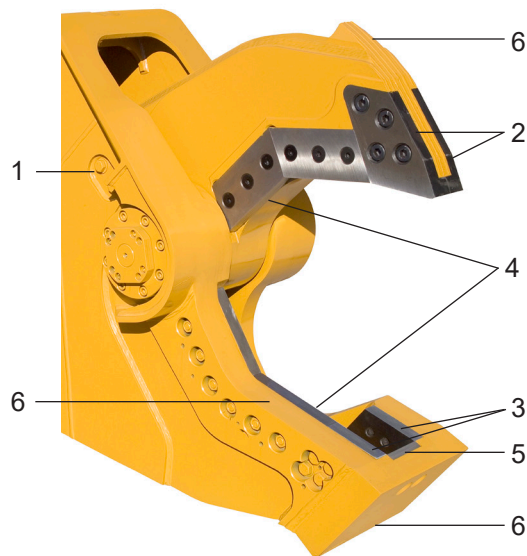

AUTOGUIDE

The AutoGuide (or puck) makes light contact with the wear surface of the upper jaw to maintain proper jaw alignment. Check the puck daily for wear or damage, replacing when grease grooves are no longer visible.

Tolerances between the puck and the wear surface should be 0.005" to 0.010".

- ✓ Check tolerances every eight hours of operation and shim as needed.
- ✓ Never overtighten the puck against the wear surface.
- ✓ Perform puck maintenance and shimming before performing blade maintenance.

Note: The GXP 200 does not have a puck, as this model is designed to maintain jaw alignment and resist side-loads without this feature.

AutoGuide Adjustment Procedure

Use the following procedure to maintain the proper gap and shim the puck.

- Slowly close the upper jaw until the puck is centered on the wear area.
- Check the gap, using a feeler gauge or shims.
- Loosen the bolts on the outside of the stick.
- Insert shims and tighten bolts.
- Check gap with feeler gauge.

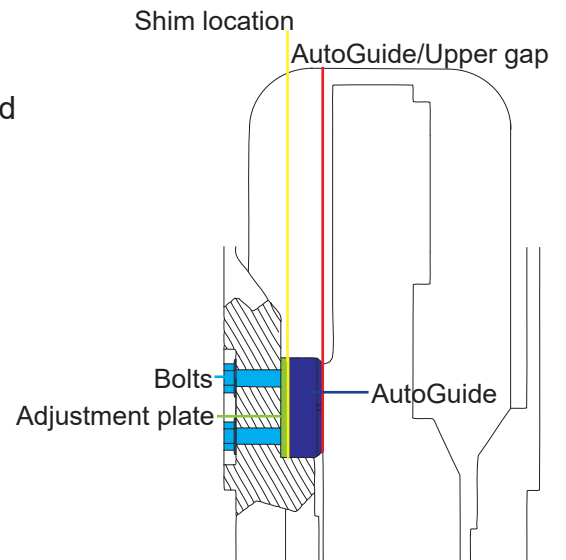
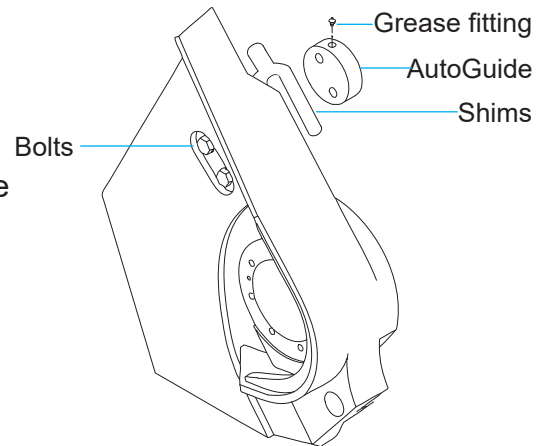

PIERCING BLADES

Piercing blade maintenance is crucial to productivity and safe shear operation. An improper blade gap may cause material jamming and/or blade breakage.

Use the following procedure to check for wear.

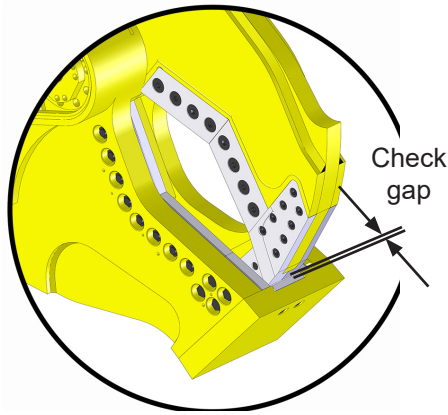

1. Slowly close jaws until the piercing blades are flush with the top edge of the razor blade.
2. Check gap with a tape measure. Acceptable gap is 5/8".
3. Check the condition of the piercing blades with a straight edge or square.
4. Check the profile along the blades.
5. Badly worn blades must be replaced. However, slightly worn blades may be squared up with a grinder and a square. This may be repeated until a maximum of 1/2" of material is removed from the lower piercing edge.
6. Typical use requires blade replacement at approximately 200 hours; heavy piercing requires replacement at approximately 40 hours. These are general guidelines only. Replace blades based on wear not hours of operation.
7. Width of blades, top to bottom, may taper 0.060" (2 mm) total. Bottom edges may be worn to a maximum radius of 3/16".

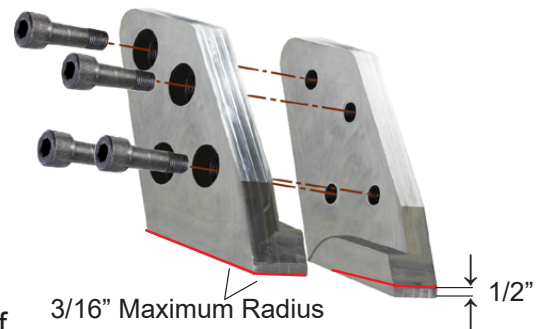

PIERCING BLADES

Piercing blades must fit tightly in some areas while having clearance in others. Piercing blades are made from the same material as the cutting blades to withstand the friction caused by piercing hard materials.

Areas **Highlighted in Blue** require contact fit to the upper jaw and tang to prevent shattering.

Areas **Highlighted in Red** require an air gap, and blades may occasionally need to be ground down to provide clearance.

Piercing blade contact with the clearance areas (**red**) can cause abnormal stress in the blade. This may cause the piercing and/or guide blades to crack, break or shatter.

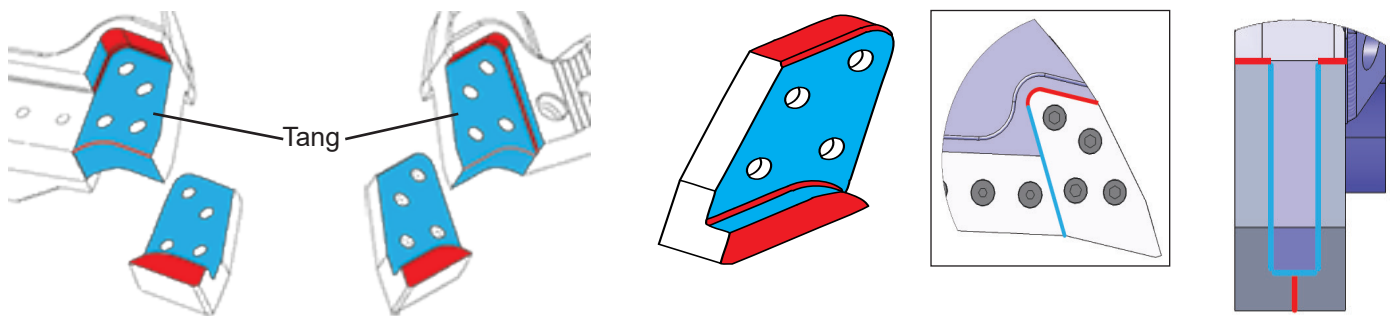

When necessary, build up the front lower edge of the tang and the front vertical surface of the upper (areas **highlighted in yellow**), following the procedures given in this manual. After welding, surfaces should be squared with a grinder and finished with a file and a machinist's straight edge.

It is critical that the piercing blade pocket and tang surfaces are straight and true, without dings, deformations, high or low spots, or areas that are worn away.

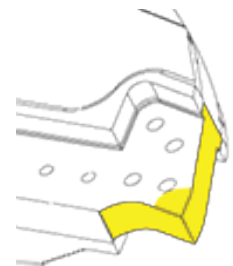

Piercing blade bolts must not make hard contact with the bolt holes in the upper tang. In rare cases it has been noted that improper alignment of piercing blade bolt holes and the bolt holes in the tang can cause the piercing blades to break through the bolt holes.

When installing the piercing blades, the bolts must be freely installed by hand, not with an air impact wrench.

The bolts may start freely, but when the bolt shank, which is larger in diameter than the threads, enters the hole in the tang, the interference can cause side loading to the piercing blades. This can cause the tips to break as they try to force the holes apart, or it may force the tips to seat improperly on the tang which can also cause tip failure. This is not a common issue, but one that should be noted as part of routine tip maintenance to prevent unnecessary costs and downtime. If this situation is encountered, contact the Genesis Parts or Service Departments for further instructions.

PIERCING BLADES

Replacement

1. Remove blades using an air-impact wrench or breaker bar and multiplier.
2. Remove dust and debris from blade seats; wipe down with a rag and solvent.
3. Lightly file deformities from blade seat edges. Do not sand or grind face of blade seats.
4. Install new, clean blades. Lubricate the threaded holes in the blade and on the bottom of the bolt head where it will contact the blade.
5. Snug lubricated blade bolts by hand to hold them in place; push blades up and into the upper and rear surfaces of the seats.
6. Torque bolts to 1/3 of the final torque value.
7. Check for firm contact against blade seats.
8. With a feeler gauge, confirm gap of 0.002" to 0.010" where blades meet at piercing surface. A very narrow gap may be confirmed by shining a flashlight from below the blades and seeing light pass through. If gap exceeds 0.010", call the Genesis Service Department. If no gap exists, remove blades, lightly grind facing surfaces and repeat steps 5-8.
9. Torque bolts to 2/3 final value, and then to final value, using a cross bolt pattern.

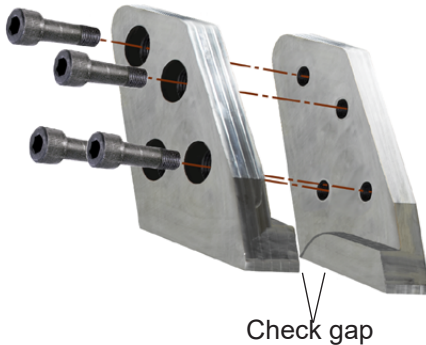

NOTICE

Piercing blade bolts must be lubricated and torqued as specified in the Genesis Fastener Manual.

Correct clamping force is required to keep tips from moving on their seats. Over-tightening can cause bolt shanks to stretch, losing their clamping force. Loose bolts will cause the seating areas to erode.

GUIDE BLADES

After adjusting the AutoGuide, check guide blade tolerances. When necessary, shim the guide blade to keep the gap within the specifications listed in the Blade Gap table below.

Rotate the guide blades when worn to a 1/8" (3 mm) radius. Replace a guide blade when more than 0.075" (2 mm) of shims are required to keep the blade gap within tolerance.

Dual guide blades, one on either side of the lower jaw, allow for a wider tip-to-guide blade gap than is used between the main cutting blades. Friction and heat buildup cause piercing blades to expand, reducing clearance, possibly to the point of blade interference. Therefore, in most applications, it is beneficial to maintain a wider gap at the guide blades.

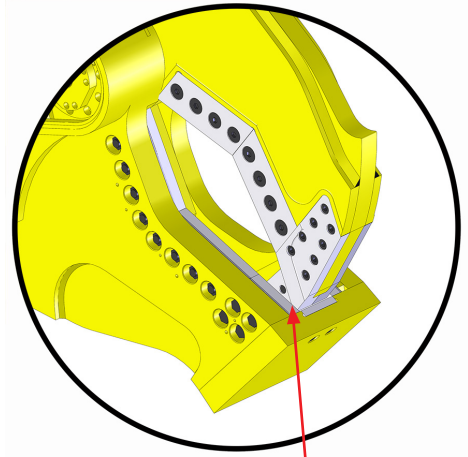

Blade Gap Location

Guide Blade to Piercing Blades Gap		
Model	Minimum	Maximum
200	0.010"	0.020"
300	0.010"	0.020"
400	0.010"	0.020"
500	0.015"	0.025"
660	0.015"	0.025"
700	0.015"	0.025"
990 ¹	0.015"	0.025"
1000	0.015"	0.025"
990 ²	0.020"	0.030"
1200	0.020"	0.030"
1500	0.020"	0.030"
2500	0.030"	0.040"

¹ 4 bolt tips

² 6 bolt tips

Shimming

Slowly close the jaw so the upper piercing blades begin to bypass the guide blades. Stop the jaw and check the gap between the guide blades and piercing blades. Cycle the jaws slowly, stopping at several points along the piercing blades to check the gap each time.

Shim the guide blades as needed to keep the gap within the tolerances listed in the Blade Gaps table.

To install shims, loosen blade bolts and slide shims between the guide blade and guide blade seat. Re-torque bolts and recheck the gap.

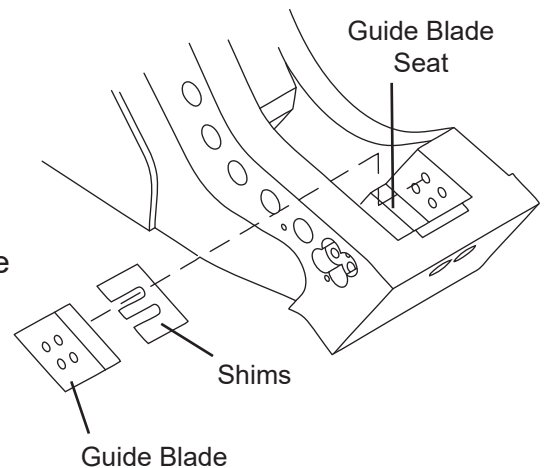

GUIDE BLADES

Rotation

Remove the blade bolts, guide blade and shims. Rotate the blade end-for-end or side-to-side; reinstall and torque bolts. Check gap; shim if required.

If the guide blade faces are excessively worn, the blades cannot be rotated. Excessively worn blades will have uneven surfaces that, when placed upon guide blade seat surfaces, will not be supported and will break, resulting in blade seat damage.

Replacement

Remove guide blade and shims. Install new guide blade with no shims. Check blade gap and shim as needed.

Adjustment Plates

Do not remove the guide blade adjustment plates from the lower jaw during routine blade rotation or replacement. These plates are custom-machined for each shear and need only be replaced when lost, damaged or extremely worn.

Inspect the top of the adjustment plate for burrs, nicks or other imperfections that may prevent proper seating of the guide blade and cause errant blade gap readings. Clean the adjustment plate as necessary. Inspect the blade seat for damage or imperfections and clean or repair as necessary.

Replacement plates can be ordered from your Genesis dealer or the Genesis Parts Department with the serial number of your shear.

Offset dowel or fastener holes are located in each adjustment plate. When replacing adjustment plates, make sure these holes are aligned with the corresponding holes in the blade seat. Chamfered adjustment plate edges go toward the back of the seat.

Do not grind blade seat areas.

PRIMARY AND SECONDARY BLADES

Proper maintenance of the primary and secondary blades, or cutting blades, is required for optimal performance. Blade rotation extends blade life and improves cutting performance. Shimming to maintain blade tolerances helps prevent jamming. Dull blades make the excavator hydraulic system work harder and may cause structural damage to the shear.

Inspect blades every eight hours of operation. Re-torque loose bolts and replace broken bolts. Grind away dents or mushrooming of blade edges at the end of each day to prevent upper jaw deflection, excessive blade wear and undue stress to upper and lower jaws.

Rotate blades to use all four cutting edges. Always use Genesis-approved blades. Blades that do not meet Genesis specifications can cause major problems, and using them may void the warranty.

Before performing any blade maintenance, read, fully understand and follow these safety rules.

Wear personal safety equipment including gloves, safety glasses, safety boots and proper clothing.

Safe blade maintenance requires two people - one to steady the blade while the other loosens the bolts.

Blades are heavy and may fall out of the blade seat if not adequately supported. Bystanders must stand clear.

Never strike a blade with a hardened steel tool. The blade may fragment, creating sharp flying debris.

Removal

Loosen the bolts on one blade at a time, enough to loosen the blades.

If blades remain tight, insert a 7/16" brass drift pin into the through-hole on the lower jaw. Tap the drift pin with a hammer until the blade is loose.

Carefully remove bolts and blades.

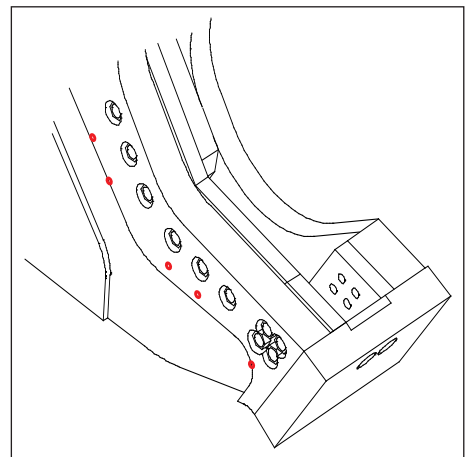

PRIMARY AND SECONDARY BLADES

Adjustment Plates

Do not remove the adjustment plates from the lower jaw during routine blade rotation or replacement. These plates are custom-machined for each shear and need only be replaced when lost, damaged or extremely worn.

Inspect the top of each adjustment plate and seat for burrs, nicks or other imperfections that may prevent proper seating of the blades and cause errant blade gap readings. Clean the adjustment plates as necessary.

Replacement plates can be ordered from your Genesis dealer or the Genesis Parts Department with the serial number of your shear.

Offset dowel or fastener holes are located in each adjustment plate. When replacing adjustment plates, make sure these holes are aligned with the corresponding holes in the blade seat.

Do not grind blade seat areas.

Rotation

Rotate blades when the cutting edges are worn to a 1/8" (3 mm) radius.

Recommended rotation intervals are approximately 40-80 hours, depending on the material being processed. Thin materials may require shorter rotation intervals. Blades must be replaced when all four edges are worn to 1/8" (3 mm) radius.

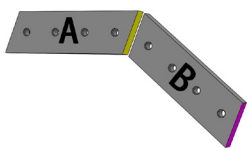
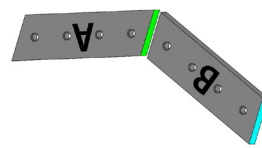
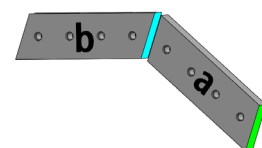
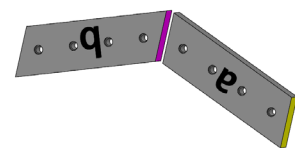
Original Blade Configuration	First Rotation Rotate both blades end-for-end	Second Rotation Rotate both blades front-to-back and exchange seat positions	Third Rotation Rotate both blades end-for-end
			

The following chart may be copied and used to track blade rotation.

40 - 80 Hours	Date	Hour Meter	Performed By
Installed			
Rotation 1			
Rotation 2			
Rotation 3			

PRIMARY AND SECONDARY BLADES

Blade Gap

After each blade rotation, shim the lower blades to keep the gap within the specifications listed in the table below. Do not shim the upper blades. Use only Genesis shim kits.

Cutting Blade Gaps		
Model	Minimum	Maximum
200 & 300	0.005"	0.015"
400	0.010"	0.020"
440 ¹	0.010"	0.020"
500	0.010"	0.020"
660	0.010"	0.020"
700	0.010"	0.020"
990 ¹	0.010"	0.020"
1000	0.010"	0.020"
990 ² , 1200 & 1500	0.015"	0.025"
2500	0.020"	0.030"

¹ 4 bolt tips

² 6 bolt tips

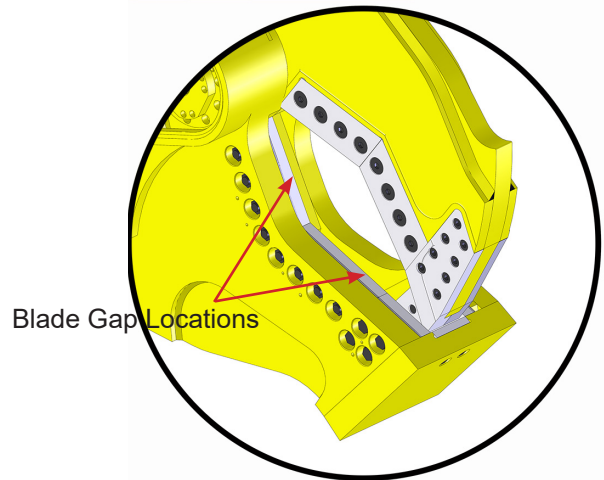

Blade Gap Measuring Procedure

Slowly close jaws until blades begin to bypass. Stop the jaw and check the gap with a feeler gauge.

Cycle the jaws slowly and continue checking the gap at several points along the entire length of the blades.

Note: The gap will be consistent along the entire length of the blades if they have been rotated and shimmed correctly.

If the blade gap exceeds the maximum listed on the table above, shim the lower blades. Blades must be replaced when shims exceed 0.060".

Shimming

Loosen blade bolts.

Install shims between the blades and adjustment plates as needed to bring into tolerance.

Torque bolts to spec and recheck the tolerances.

Do not use more than 0.060" of shims.

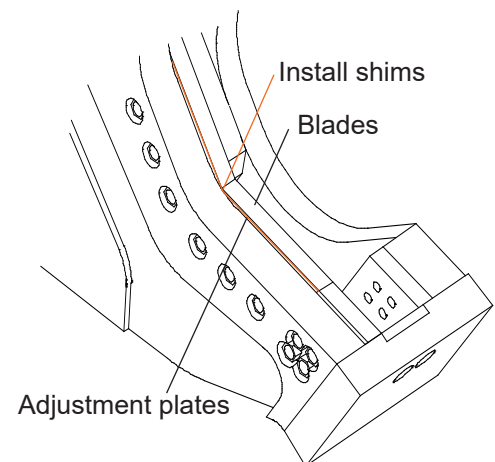

RAZOR BLADE

Check the razor blade for wear every eight hours of operation. Rotate when worn, using the edges in the sequence indicated by the illustration.

After rotation, check the gap between the razor blade and piercing blades. If the gap exceeds the maximum tolerance after new piercing blades have been installed, the razor blade must be replaced. Do not shim the razor blade.

Set-screws should be installed in unused bolt holes to prevent thread and hole damage. Replace set-screws when lost or damaged.

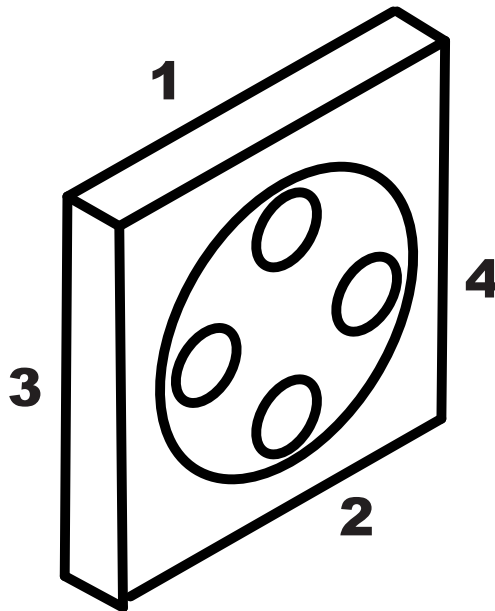

GENERAL WELDING GUIDELINES

Build-up and hard-surfacing are welding procedures that protect the parent material of the jaws and keep the blades in good adjustment. Build-up is the welding procedure that restores the jaws to their original shape. Building up the jaws helps protect the blades and increases the life of the shear. Hard-surfacing is the welding material added over the parent material (or build-up material) to create a wear-resistant surface.

Welding should not be performed until the jaws are work-hardened. Work-hardening can take up to 80 hours. However, jaws must not wear lower than the height of a new blade. If either jaw wears down lower than blade height, immediately stop operating the shear and perform build-up and hard-surfacing as described in the following pages of this manual.

When welding around blade seats or the piercing tip tang area, maintain the factory machined seat radius. If the rounded grooves are welded up, use a die grinder with a carbide tool to recut these areas to their original profile. Leaving a squared edge will eventually cause structural cracking. The radius provides a broader area to absorb structural stress.

Welding Ground Clamp

Disconnect all battery ground cables or shut off master battery switch, if equipped. Failure to do so may cause excavator electrical problems, including permanent damage to onboard computer systems.

Connect ground clamp as close as possible to the area being welded without allowing current to pass through the pivot group, cylinder pin, cylinder, swivel, motor, gearbox or slewing ring.

If you are welding on the lower jaw, connect weld clamp to the lower. If you are welding on the upper jaw, connect to the upper but not to the cylinder clevis. If needed, weld a piece of steel to the area for the grounding clamp and cut the piece off when welding is completed.

Welding Rules

Before you begin:

- Remove adjacent blades, as preheating and welding may cause blade damage.
- Wearing an approved respirator, grind the area to clean it, removing all existing hard-surfacing.
- Preheat area to 350° F (177° C). Maintain this temperature throughout the procedure. Do not exceed 450° F (232° C) interpass temperature.

During welding:

- Always grind and weld with the grain of the material.
- Peen each weld pass to relieve stress and harden the welds.
- Do not undercut the ends of the welds.
- Do not start or stop welds directly above a bolt hole or in the apex of the jaw.

After welding maintenance is complete:

- Cover the area with a heat blanket and allow it to cool slowly, approximately eight hours.
- Do not put the shear into operation until the welds have been allowed to cool.

BUILD-UP

Procedure:

Follow the General Welding Guidelines and Rules.

Determine the area to build up, using a straight-edge or square. Jaws must not wear lower than the height of a new blade. Use a new blade to help determine build-up height for the jaw.

Build up the jaw to slightly higher than the original parent material profile with E7018. Apply single passes in each line with the grain of the steel, peening after each pass.

Protection strips, or raised areas under or around blade seats, must be built up and maintained during build-up procedure using E7018 or equivalent.

These areas should be maintained between blade height and 0.010" lower than blade height. These areas protect the bottom unused edges of the blades as well as reduce the chance for material to catch on the bottom of the blade during jaw open functions, which causes blades to move in their seats.

Denting, deformation or build-up higher than blades in these areas may cause upper jaw deflection, excessive blade gaps, wear to blade faces and undue stress to upper and lower jaws.

After build-up is complete, grind material to be flush with a new blade.

Note: Closely monitor areas above guide blade bolt countersinks and below front two upper blade bolt countersinks. These are high-wear areas. If allowed to wear too far, parent material starts to fold into the countersinks, and it becomes time-consuming to clean out this area when access is needed for blade rotation and replacement.

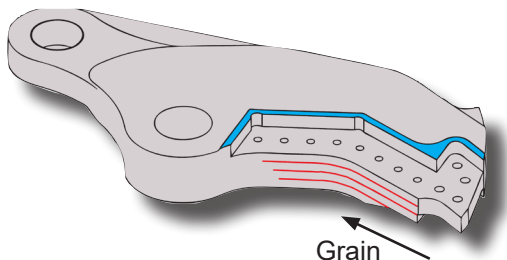

Area highlighted in blue illustrates protection strip.

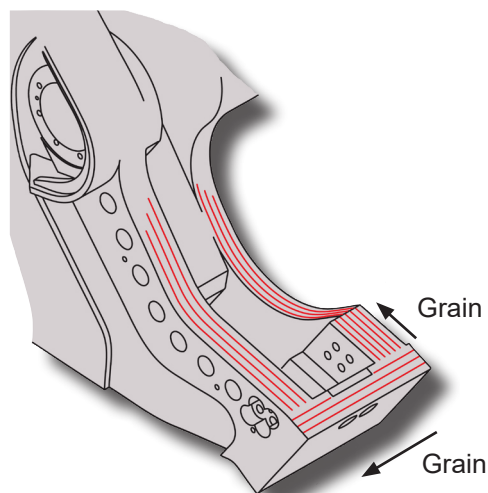

HARD-SURFACING

Do not apply hard-surfacing directly to the parent material as this could cause toe cracking, and the hard-surfacing will break away.

Procedure:

Follow the General Welding Guidelines and Rules.

Apply a single pass stringer bead pattern, with the grain, using E7018 electrode. Peen each pass.

Do not apply a stringer directly on the edge. Start the first pass 1/4" from the edge.

Stagger the ends of the stringer welds so they do not end in a straight line.

Cap each stringer bead with one pass of GenWire or GenRod to hard-surface. Do not apply more than two layers of hard-surfacing. Peen each pass.

Grind the ends of all stringer welds, with the grain to taper 1" to 1-1/2" (25 - 38 mm) to the parent material.

See the following page for hard-surfacing illustrations and instructions specific to each area of the jaws.

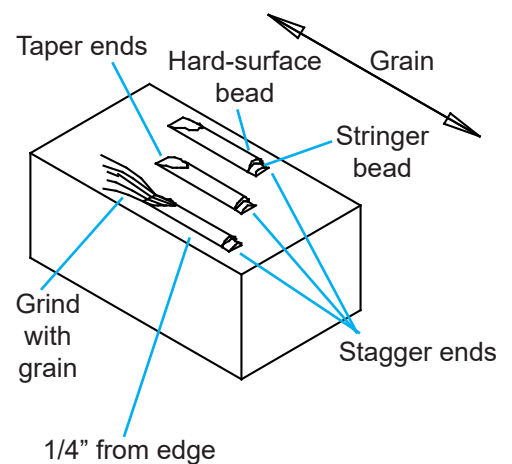

HARD-SURFACING PATTERNS

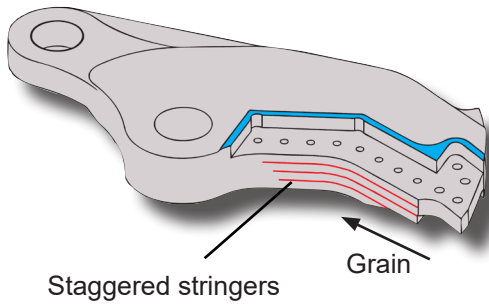

Upper Jaw

Single passes approximately 1" apart. Begin just behind the piercing blade seats and continue toward the throat. Use three to five stringers, depending on the shear model.

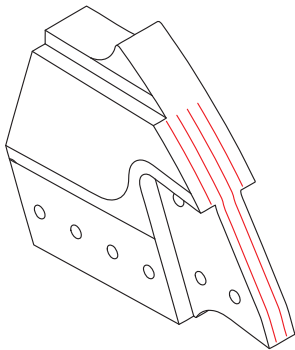

Upper Jaw Face

Single passes approximately 1" apart. Begin at the bottom of the upper face and continue approximately 2/3 up the front face.

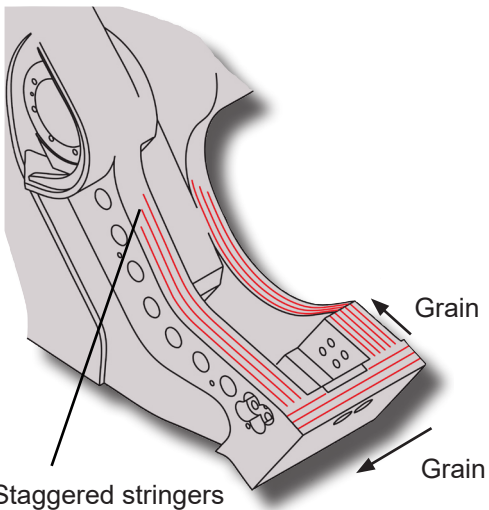

Lower Jaw

Single passes approximately 1" apart. Work across the top of the chin plate and along the lower jaw toward the throat. Use two to three stringers, depending on the shear model.

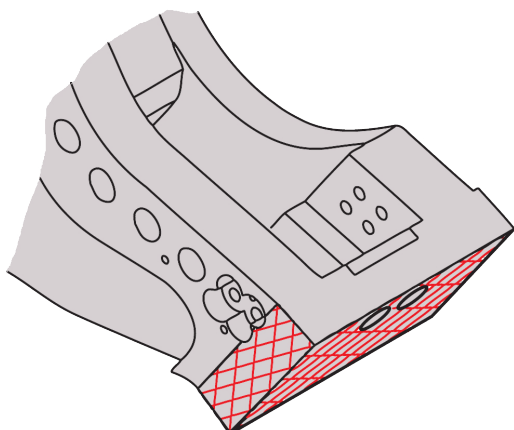

Lower Jaw Chin

Crosshatch the chin plate with stringer beads at 45° angles to form 1" squares.

HYDRAULIC/ROTATION MAINTENANCE

Hydraulic Requirements

Operating the shear below the recommended flow and/or pressure range will adversely affect performance and may damage the rotate motor.

Operating the shear above the recommended flow and/or pressure range may damage the shear and its hydraulic components.

Model	Flow	Pressure
200	40-60 GPM 151-227 LPM	4500-5500 PSI 310-380 Bar
300	60-90 GPM 227-340 LPM	
400	75-110 GPM 284-416 LPM	
500	85-125 GPM 322-473 LPM	
660 & 700	105-155 GPM 397-587 LPM	
990 & 1000	150-190 GPM 568-719 LPM	
1200	175-240 GPM 662-908 LPM	
1500	180-250 GPM 681-946 LPM	
2500	245-320 GPM 927-1211 LPM	

Rotation Valve Input

For cooler and more efficient hydraulic system operation, set the input pressure as indicated in the chart.

The maximum case drain measured at the shear while rotating and cycling the jaws must never exceed 80 PSI or 40 PSI for axial piston motors. Pressure increases during cold-weather operation.

Model	Flow	Pressure
200 & 300	3-5 GPM 11-19 LPM	1500-1700 PSI 103-117 Bar
400 - 660	7-11 GPM 26-42 LPM	1800-2000 PSI 125-138 Bar
700 - 1000	8-12 GPM 30-45 LPM	
1200 & 1500	12-18 GPM 45-68 LPM	
2500	30-45 GPM 114 - 170 LPM	

Rotation Valve Settings

When checking the crossover relief valve settings, put pressure gauges on both diagnostic ports. Stall shear rotation in clockwise direction. Increase supply pressure until pressure at gauge on crossover stops rising. This is the crossover relief setting. Increase supply pressure to achieve approved crossover relief value. Repeat procedure in counter-clockwise direction. Then lower supply pressure back to approved value.

Model	Crossover Relief
200 & 300	2100 PSI 145 Bar
400 - 660	2200 PSI 150 Bar
700 - 1000	
1200 & 1500	
2500	

HYDRAULIC/ROTATION MAINTENANCE

GenFlow Regeneration Valve

Your regeneration valve features a GenFlow adjustment cartridge to control the timing of the shift between speed and power modes. When the cartridge is properly set, the shear closes rapidly until it begins to cut. The valve shifts, slowing jaw close and increasing power. You may hear a squeal or hiss as this happens. The valve shifts back into speed mode after the cut is complete.

The cartridge is factory-set, turned out approximately seven turns. This setting is appropriate for most applications. However, the cartridge may be custom-set if necessary. Contact Genesis before adjusting a new shear.

Regeneration Valve Adjustment

Check the cycle time when the hydraulic fluid is warmed up, timing from full open to full closed and back to full open.

To shift into power mode sooner, turn adjustment cartridge out (counter-clockwise). To shift into power mode later, turn in (clockwise).

Genesis uses regeneration valves from two sources. The adjustment cartridge on an F48-1 valve is on the side opposite the hoses. On an F48-2 valve, the adjustment cartridge is on the side of the block next to the hose connections.

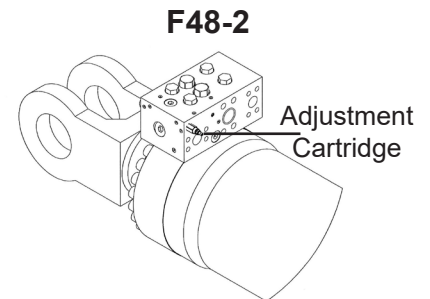
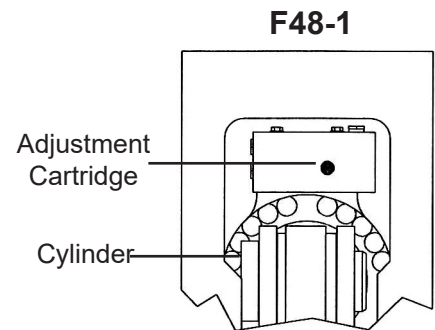

Shut off the excavator and disable the hydraulics per OEM instructions before adjusting the cartridge.

REGENERATION VALVE ADJUSTMENT

Adjustment Procedure 1

This method requires a hydraulic gauge with a range up to 6000 PSI or higher, with the capability to record the maximum pressure achieved.

1. With the excavator at idle speed, open the shear jaw to full open then slowly close to about 12 inches from full open.
2. Shut down the excavator, bleed down all circuits and remove the hydraulic tank cap.
3. Remove the cylinder access cover carefully as it is heavy.
4. On F48-1 valves, slowly remove the plug marked GR from the top of the block and install the gauge. On F48-2 valves, slowly remove the plug marked GB from the front of the block and install the gauge.
5. Install the fill cap on the excavator hydraulic tank.
6. Start the excavator and run at idle speed.
7. Zero out the gauge.
8. Insert material into the jaws to test cut. This must be heavy enough for the shear to shift into the power mode.
9. If you are not operating the shear, maintain a safe distance of at least 75 ft. from the operating shear.
10. Close the jaw all the way and record the gauge reading. This reading should be approximately 1200 - 1500 PSI. If the reading is low, gradually turn the adjustment cartridge in (clock-wise) with a 5 mm allen wrench.

If the reading is high, back out the adjustment cartridge gradually (turning counter-clockwise). Open jaw 3/4 of the way open. Close jaw half-way. Repeat steps 7 - 10 above until the reading is between 1200 - 1500 PSI. Tighten jam nut on adjustment cartridge and repeat procedure several times to assure setting hasn't changed.

Adjustment Procedure 2

This method requires two people.

1. Shut down the excavator, bleed down all circuits and remove the hydraulic tank cap.
2. Remove the cylinder access cover carefully as it is heavy.
3. Loosen the lock nut with a 17 mm socket.
4. Turn cartridge 180° (half-turn) with a 5 mm allenhead socket.
5. Tighten the lock nut.
6. Check the cycle time.

Repeat until the preferred balance of speed and power is met. Final adjustment may require less than a half-turn.



WARNING

The ground crew must be in full view of the operator at all times and must stand clear of the shear jaws when cycling.

GENFLOW REGENERATION VALVE - HOW IT WORKS

Jaw Close in Regeneration: Oil that would normally leave the rod end of the cylinder and return to the tank is diverted to the bore end of the cylinder, increasing flow by approximately 50 percent and speeding up jaw close. In this mode, oil pressure on both rod and bore sides of the cylinder piston are basically equal and, although this speeds up the cylinder extend speed, it results in pressurized fluid on the rod side. If left in this mode, cylinder power is greatly reduced.

Jaw Close in Power Mode: To provide full power, when the upper jaw hits the material, the pressure rises. Once pressure exceeds the adjustment cartridge settings, it then shifts the rod oil back to the excavator hydraulic tank instead of the bore end of the cylinder. Pressure in the rod also drops, allowing full force from the bore pressure to be applied to the upper jaw for full cutting.

Jaw Open: Oil goes to the rod end of the cylinder, and bore oil goes back to the tank.

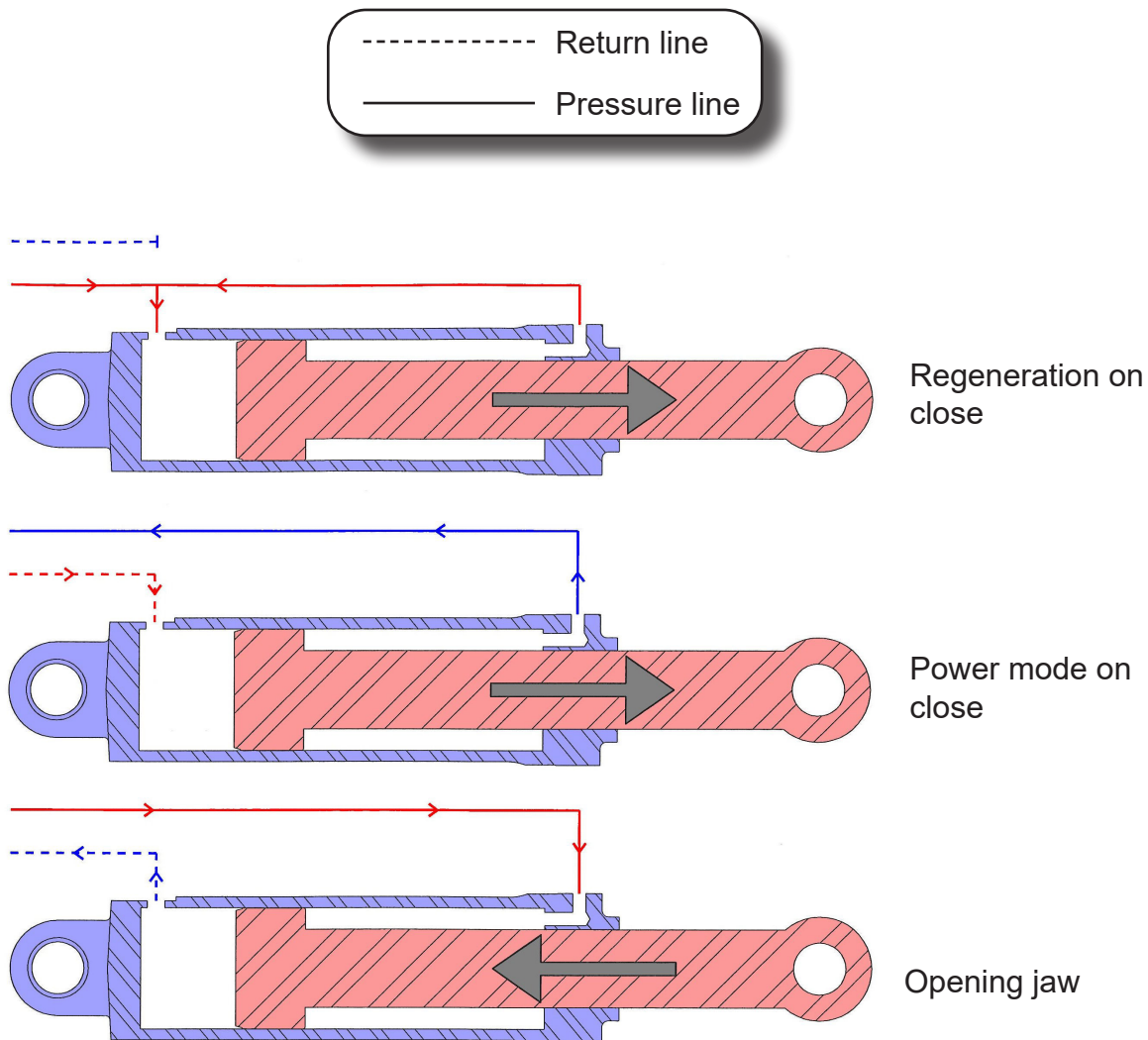

Valve 6300830

Check valve 6380011
External seal kit SK00023
Torque to 454-486 ft-lbs

Directs oil into rod from excavator while retracting; blocks oil path between rod and tank at all times.

Logic valve 6300623
External seal kit 6300624
Torque to 454-486 ft-lbs

Directs oil from rod to tank in power mode; blocks oil path from rod to tank in speed mode.

O Ring 6300723

Pilot check valve 6300061
External seal kit SK00024
Torque to 454-486 ft-lbs

Directs oil from rod to bore in speed mode; blocks oil path between rod and bore in power mode.

Bleed down orifice

If plugged, jaw will drift closed.

Pressure reducing valve 6300625
External seal kit 6300622
Torque to 31-35 ft-lbs

Shifts between speed and power modes.

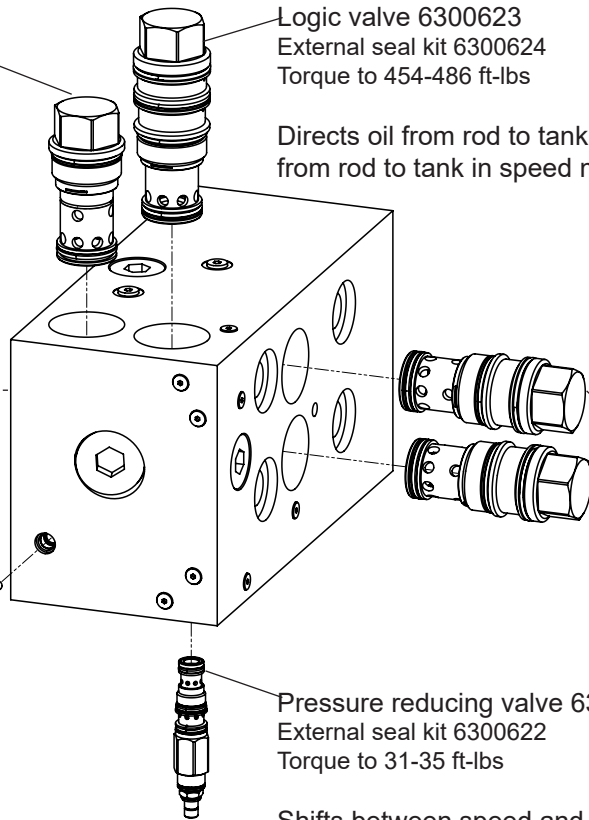

SLEWING RING MAINTENANCE

Visually check slewing ring (rotation bearing) bolts every eight hours of operation. Do not reuse or re-torque these bolts. Loose or broken bolts, along with the bolts on either side, must be immediately replaced.

The bolts that secure the slewing ring are critical for safe attachment operation. Improper torque may cause the bolts to fail and the attachment to break free, which may result in serious personal injury and equipment damage. Improper torque will also cause uneven slewing ring wear.

Rotating components must be greased daily. Grease fittings are located on the outside of the slewing ring and on the inside of the rotating head assembly. Grease locations are marked with decals.

Grease each fitting and then rotate the attachment two full rotations.

For normal conditions above 32°F (0°C), use a lithium-based, premium grade 2 extreme-pressure grease. For temperatures below 32°F, use a grade 0 grease. **Do not use grease containing Molybdenum (Moly).**



Genesis GLG-2® anti-wear, extreme-pressure lithium grease, PN 6302601, is recommended for all temperature conditions.



Stand clear when the attachment is being rotated. Always stay in clear view of the operator.

GEARBOX MAINTENANCE

Planetary Gearbox Lubrication

Proper lubrication is critical to ensure performance and long life of the gearbox. Change gearbox lubricant after the initial 50 hours of operation. Check gearbox lubricant every 250 hours. See table for recommended grades and lubricant change-out schedule based on climate.

Low Temp.	Grade	Change
5° F (-15° C)	SAE 80W-90W	500 hours or annually
-50° F (-45° C)	Synthetic ISO 150	1000 hours or two years

Gearbox Lube Change-out Procedure

1. Position the shear so the gearbox is horizontally level at a convenient working height.
2. Remove the rotator access cover and place an oil drain pan under the gearbox drain plug (Port B).
3. Remove the bottom drain plug (Port B) and top fill plug (Port A).
4. Once drained, replace the bottom drain plug (Port B).
5. Add lubricant through the fill plug to 1-1/2" from the top of the fill plug (Port A). Do not overfill.
6. Replace the fill and inspection plugs. Reinstall the access cover.
7. Properly dispose of the used lubricant.

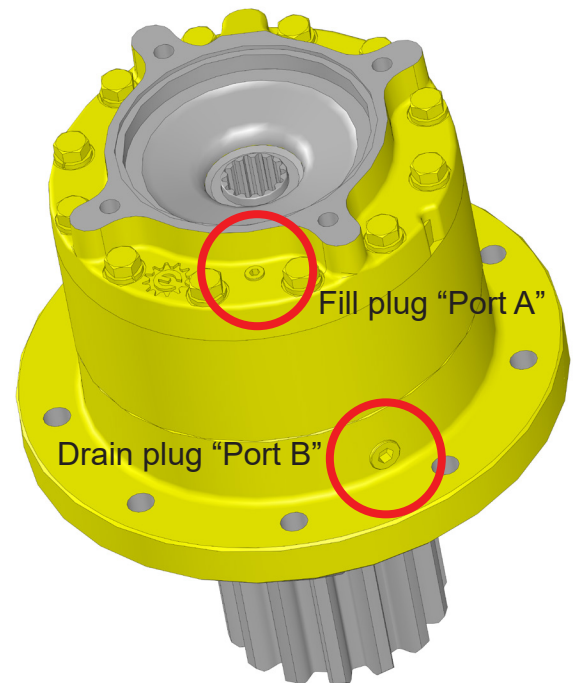

Reminder: The gearbox oil level should be 1 1/4" to 1 1/2" below the fill plug with the gearbox positioned vertically.

ROTATION CIRCUIT

To meet diverse customer needs, Genesis offers several rotation valve options. These options vary in mounting, function, factory-supplied and customer-supplied parts, and operating advantages. For information on each type of rotation circuit, see the chart below and information on the following pages.

Valves are factory-set and should not need adjustment. If you believe adjustment is necessary, contact the Genesis Service Department. Unauthorized valve adjustment may void the warranty.

All rotation circuits use the same procedure for setting flow:

Rotate shear, timing one complete revolution.

Adjust the corresponding flow control until the revolution time is 14-16 seconds.

Repeat in opposite direction.

Note: Genesis does not recommend using the excavator bucket circuit for rotation circuit directional control as it may damage the rotation components.

Rotation	Auxiliary Valve	Gear Pump	Accumulator Valve
Mounting	Crossover relief on shear; valve on excavator or shear	Crossover relief on shear; valve on excavator	On shear
Function	Mounted on excavator, directional control valve gets oil from excavator hydraulic system to control rotation Mounted on shear, it gets oil from port blocks	Dedicated oil from gear pump supplies rotation directional control valve on excavator	Oil from jaw open/close circuit charges accumulator; shear rotates when accumulator is electrically actuated
Factory Supplied	Crossover relief protection; rotation speed control *Note: Input flow and pressure should not exceed 12 GPM and 2500 PSI	Crossover relief protection; rotation speed control; foot switch and wire harness	Accumulator; crossover relief protection; rotation speed control; directional control valve; foot switch and wire harness
Customer Supplied	Rotation circuit with directional control from excavator; case drain	Gear pump; case drain; must install wiring	Case drain; return line; must install wiring
Advantage	Allows shear to open/close and rotate simultaneously when mounted on excavator	Allows shear to open/close and rotate simultaneously	Lower installation cost; easier move to other excavators
Disadvantage	If directional valve is mounted on shear, it receives flow only from shear ports		Limited rotation due to accumulator capacity

ROTATION CIRCUIT

Rotation with Crossover Relief Valve

Setting the crossover reliefs:

1. Increase supply pressure to the rotation valve to 2500 PSI.
2. Install pressure gauges on relief test ports.
3. Plug hoses at motor or secure the shear from rotating.
4. Pressurize the valve to rotate.
5. Adjust the corresponding relief valve to the pressure specified in the rotation valve setting table.
6. Repeat for the other direction.
7. Reduce supply pressure to the pressure-reducer valve setting specified in the rotation valve setting table.

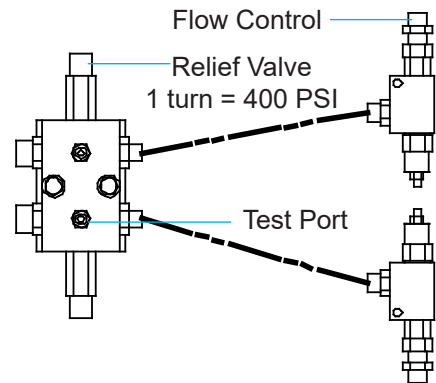

Rotation with Motion Control Valve

Follow steps 1-7 above to set the crossover reliefs.

If you cannot reach the pressure specified in the rotation valve setting table, adjust the counterbalance valves using the following procedure:

Turn the crossover relief valve adjustment screws clockwise to their maximum setting, recording the number of turns so they can later be returned to their original setting.

Adjust the counterbalance valves by turning the adjustment screws counter-clockwise until the correct setting of 2500 PSI is reached.

Repeat steps 6 and 7 for setting the crossover reliefs.

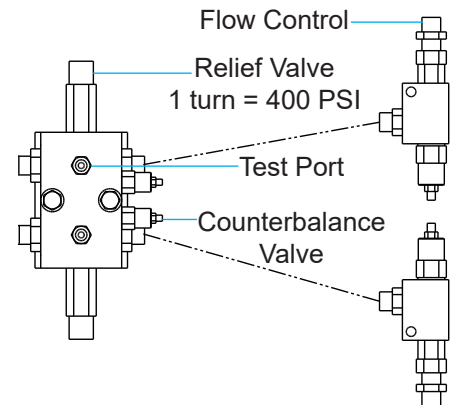

ROTATION CIRCUIT

Flow Divider Rotation

Setting the crossover reliefs:

1. Install a pressure gauge on the unloading valve, unplug the wires to the directional valve and energize the valve on the unloading valve.
2. Adjust the unloading valve to 2500 PSI.
3. Reconnect the wires to the directional valve.
4. Plug hoses at motor or secure the shear from rotating.
5. Press the switch to rotate left or right.
6. Adjust the corresponding relief valve to the pressure specified in the rotation valve setting table.
7. Repeat for the other direction.
8. Set the unloading valve before operating.

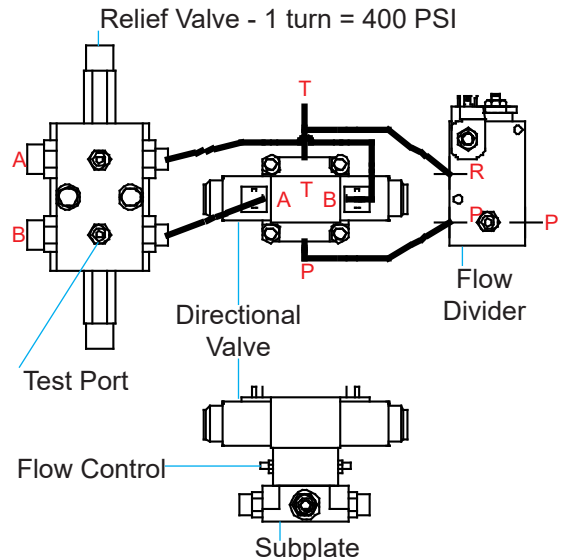

Setting the counterbalance valve (if equipped with a motion control valve) - follow the procedure in the Rotation with Motion Control Valve section.

Setting the unloading valve:

1. Install a pressure gauge on the unloading valve, unplug the wires to the directional valve and press the switch to rotate left or right.
2. Adjust the unloading valve to the pressure specified in the rotation valve setting table.
3. Plug the wires back into the directional valve.

ROTATION CIRCUIT

Accumulator Valve Rotation

Setting the crossover reliefs:

1. Install pressure gauges on the G1 and G2 ports of the control valve assembly.
2. Disconnect hoses from motor; plug ports A and B on the control valve.
3. Close jaws and hold full pressure to close.
4. Energize the circuit to rotate the shear.
5. Measure pressure at G1 and G2 ports; subtract low number from high number.
6. Release pressure and adjust the corresponding relief valve, if needed, to achieve correct relief pressure.
7. Repeat steps 3-6 to reach correct setting.
8. Repeat procedure in the other direction for the other relief valve.
9. Reconnect hoses.

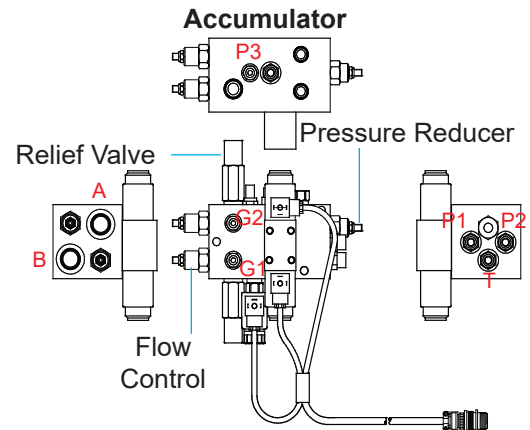

Setting the counterbalance valve (if equipped with a motion control valve): follow the procedure in the Rotation with Motion Control Valve section.

Setting the pressure reducer:

1. Install a pressure gauge on the P3 port of the control valve assembly.
2. Close jaws and hold full pressure to close.
3. Measure the pressure at the P3 gauge.
4. Release pressure; if measured pressure is not 3000 PSI, adjust reducer and repeat procedure until 3000 PSI is achieved.

ROTATION CIRCUIT

Gear Pump Rotation

Setting the crossover reliefs:

1. Increase supply pressure to the rotation valve to 2500 PSI.
2. Install pressure gauges on relief test ports.
3. Plug hoses at motor or secure the shear from rotating.
4. Pressurize the valve to rotate.
5. Adjust the corresponding relief valve to the pressure specified in the rotation valve setting table.
6. Repeat for the other direction.
7. Reduce supply pressure to the pressure-reducer valve setting specified in the rotation valve setting table.

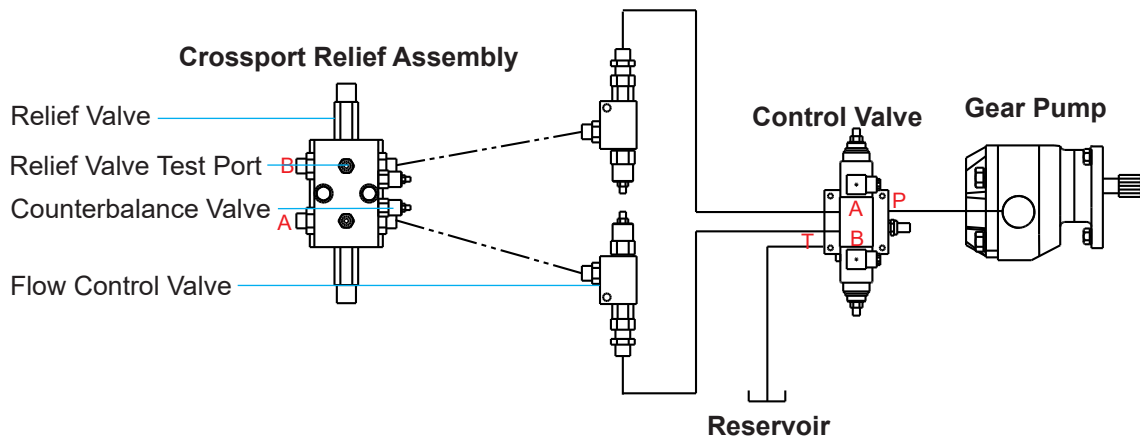

TROUBLE-SHOOTING GUIDE

Hydraulics

Symptom	Possible Causes/Solutions
Low power	Check operating pressures and back pressure at port blocks on shear
	Isolate shear from excavator and check excavator pressures at boom tip
	Shear may be partially stuck in regen mode; follow adjustment procedure in this manual
	If speed is good with low power, internal seals on logix cartridge may need to be replaced
Possible cylinder, swivel or regen bypass; contact the Genesis Service Department for procedures	
Slow jaw open with low power	Pilot check valves in the regen valve may have worn or damaged seals
Slow jaw close	Check hydraulic flows from excavator
	Check regen valve adjustment if shear is new
	Adjustment cartridge may have damaged seals or may be stuck open
	Regen check valve or logix valve may have damaged seals or may be stuck open
Good speed but shear stalls before cutting	Regen adjustment cartridge is turned in too far, not shifting out of regen mode
Jaw drifts closed or can be pushed closed	Regen bleed down orifice may be plugged
	Regen pilot check valves may be leaking
	Directional valve on excavator may be leaking
Jaw closes suddenly and will not open	Ball valve may be closed on excavator
	Regen pilot check valves may be contaminated
	Excavator valve spool may be stuck
	If shear has quick-coupled hydraulics, they may be partially disconnected or damaged
Hydraulics chatter while cutting	Tighten regen adjustment cartridge in quarter-turns and recheck speed
	Chattering may indicate a material jam
Jaw bounces back after hitting excavator relief on jaw open	Regen bleed down orifice is plugged
	Regen logix cartridge needs to be replaced/cylinder or swivel seal failure
Loud bang when shifting to speed mode	Broken spring or poppet in logix cartridge (regen valve)
Hydraulic system overheating	Check hydraulic system oil level for low or overfull condition
	Ensure clear path for hydraulic cooler-radiator and AC condenser; clean coolers and radiator with compressed air and then pressure wash
	Check with excavator dealer on whether a hot weather package needs to be installed on the excavator. Oil temperatures coming out of the shear can run as high as 230 to 240° F (110 to 116° C).

TROUBLE-SHOOTING GUIDE

Cutting

Symptom	Possible Causes/Solutions
Poor cutting	Material is beyond shear appetite range
	Material is harder than mild steel
	Blades are worn beyond 1/8" radius - rotate or replace
	Blade gaps are too wide for thin material
	Blade protection strips are too high, causing jaw deflection and excessive blade gaps
	Piercing tips are worn and need to be squared up or replaced
	Too much end play in pivot group - shim to 0.002" to 0.005"
	Wear in main bearings is causing jaw deflection and inconsistent blade gaps
	Pressures from excavator too low - check at shear port blocks
	Shear not kicking out of regeneration or kicking out at too high a pressure range - see Regeneration Valve section of this manual
	Shear swivel or cylinder is bypassing - contact the Genesis Service Department for procedures to check for bypass
Poor piercing	Piercing tips are worn and need to be squared up or replaced
	Guide blades are worn - rotate or replace
	Excessive or insufficient gaps at piercing tip and guide blades - shim to specs indicated in Guide Blade section of this manual
Material jamming	Excessive blade gaps - shim to specs indicated in Cutting Blade section of this manual
	Worn blades - rotate or replace
	Excessive or insufficient gaps at piercing tip and guide blades - shim to specs indicated in Guide Blade section of this manual
	Thin material may be wrapping around blades - fold material or draw a larger amount of material into jaws
	Thin material in opening between the guide blades before the piercing tips entered the lower jaw - operators must be aware of this area at all times

TROUBLE-SHOOTING GUIDE

Rotation

Symptom	Possible Causes/Solutions
Does not rotate	Blown fuse
	Test for 24V at plugs on directional valve while depressing foot switch
	Incorrect pressure settings; reset
Does not rotate in one direction	No electrical power to one side; test for 24V at plugs on directional valve while depressing foot switch
	Check if directional control valve shifts both ways while actuating foot switch in both directions
Rotator chatters	Electrical short; back out flow controls
	Pressure settings too high; reset
	Power to both rotation solenoids at the same time; test for 24V at plugs on directional valve while depressing foot switch
Rotates faster in one direction	One flow control cartridge is set higher than the other; reset
Rotates too fast or too slow	Flow control out of adjustment; reset
Rotation speed changed from original setting	Jam nut loosened on rotation valve
	Faulty cartridge (contamination)
	Faulty directional control valve
	Pressure set too low; reset

WARRANTY

Claim Procedure

Notify the Genesis Service Department of the potential warranty claim prior to making the repair. Digital pictures are very helpful for diagnosing problems and recommending repairs.

Contact the Genesis Service Department before making alterations, changes or repairs to any component that is going to be considered for warranty. Not doing so will void all Genesis warranty consideration.

The Genesis Service Department will issue an authorization number to track the repair costs, outgoing parts, and/or defective parts returning to the factory.

Replacement parts must be ordered using a purchase order number. Shipping is standard ground. Overnight shipping is available by request, and Genesis will not cover the shipping charge.

When the repair is complete, submit an invoice to the Genesis Service Department within 30 days. Include itemized internal labor reporting, parts lists and invoices for outside contractors. Reference the authorization number on all invoices.

When returning parts for warranty consideration, include a copy of any related Genesis paperwork along with any other necessary documentation to ensure proper processing and credit. The Genesis Service Department will provide the necessary forms.

Your account will be credited when the warranty claim is accepted.

Blade Warranty

Standard warranty on blades will only be considered on the first edge, and wear on the edge must be 1/8" radius or less. Genesis does not warranty cutting blades that are cracked or broken from top to bottom (perpendicular to the long edge of the blade). Genesis also does not cover fasteners, the labor to replace wear components or collateral damage, such as blade seats, from broken blades, the piercing blade tang or adjustment plates.

Please direct any questions to the Genesis Service Department: 715-395-5252

PARTS ORDER POLICY AND PROCEDURE

Parts Orders Should Include

- Purchase order number
- Model and serial number of attachment
- Part number and quantity needed
- Shipping and billing address
- Method of shipment or required delivery date

Placing Orders

Orders may be placed by phone or e-mail. To e-mail an order, use the form on the following page or your purchase order form. Contact information is located at the front of this manual.

Part Numbers

Part numbers are listed in a separate Parts Manual or, if included, the Parts section of this manual. Contact the Genesis Parts Department with questions regarding part numbers, availability and pricing.

Shipping

All orders will be shipped best way surface unless an alternate shipping method is requested. Shipping charges are not included in the purchase price of parts.

Invoices

All invoices are due upon receipt. Any accounts with invoices open beyond 60 days are subject to review and may be placed on C.O.D. status without further notice.

Returns

Many unused Genesis parts may be returned with proper documentation. Return shipping is the responsibility of the purchaser. Credit will be issued upon return, less a 25% restocking fee. Documentation is required for credit of returned parts. Contact the Genesis Service Department at 715-395-5252 for an RGA (Return Goods Authorization) number and form. An RGA must accompany every return. Items shipped without an RGA may be returned to sender.

Warranty Returns

All parts returned to Genesis for warranty consideration must be returned with a completed RGA (Return Goods Authorization) provided by the Genesis Service Department. The form needs to be completed in its entirety, including any additional information requested by the Service Department. Return shipping is the responsibility of the sender and will be credited upon claim approval. A determination to accept or deny the claim will be made based upon the information available to Genesis. Warranty on purchased parts other than wear components is 6 months. Genesis does not cover labor costs to replace purchased parts replaced under warranty. There is no warranty period on wear parts or components.

PARTS

The following pages contain illustrations and parts lists for GXP mobile shears. These photos and generalized drawings identify major components and may not be identical in fine detail to a particular shear.

The parts lists included here are intended to aid in shear operation and maintenance. Part numbers listed are those currently used. These may differ from the part numbers of the components originally installed in your shear. To ensure use of the correct internal components, always indicate your shear's serial number when ordering parts.

If further information is required, contact the Genesis Parts Department for a parts list specific to your shear model and serial number.

PARTS

Non-Rotating Bracket

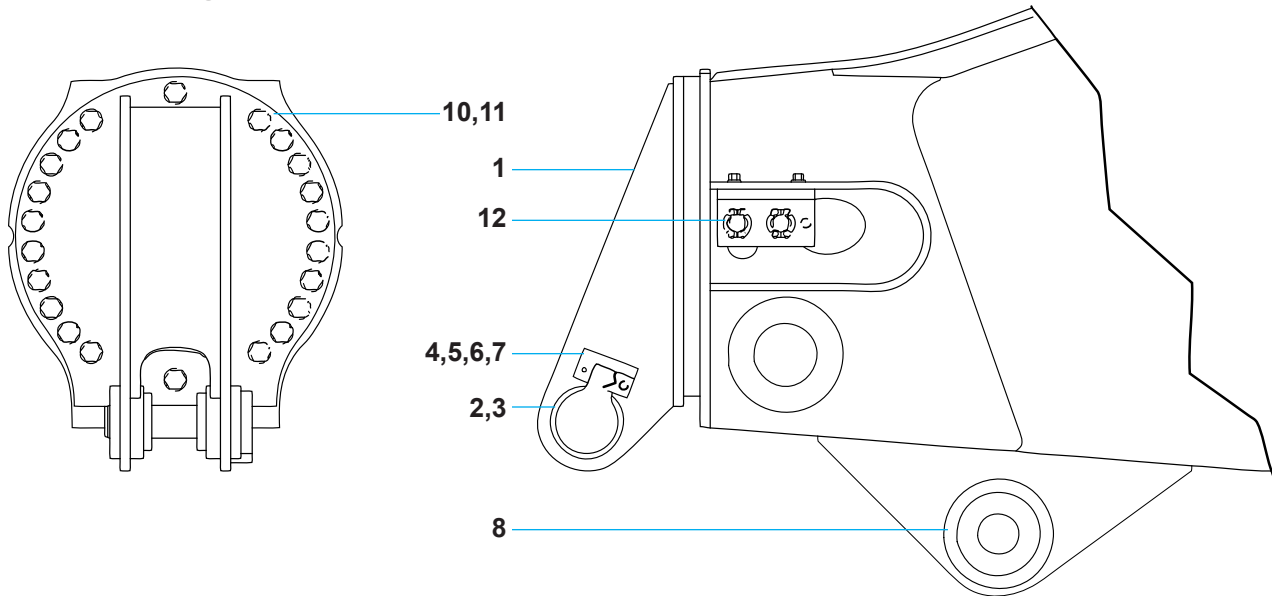

Boom pin provided by excavator OEM

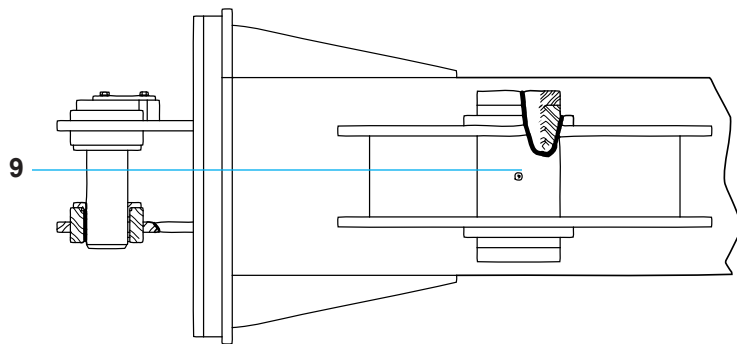

Item	Description
1	Bracket
2	Cylinder Pin
3	Spacer Sleeves
4	Pin Keeper
5	Strap
6	Bolt (hex head capscrew)
7	Lock Washer
8	Boom Bearings
9	Grease Fitting
10	Bolt (hex head capscrew)
11	Flat Washer
12	Port Block Assembly

Custom parts - call the Genesis Parts Department, 715-395-3488, for part numbers specific to your serial number.

PARTS

Rotating Bracket / Upper Head

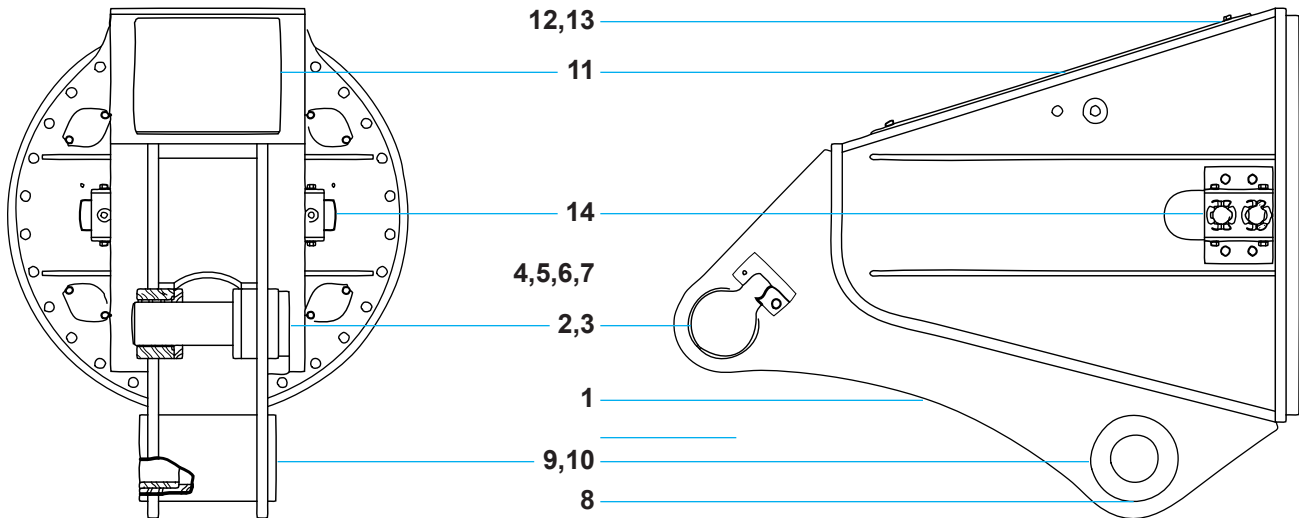

Boom pin provided by excavator OEM

Item	Description
1	Upper Head
2	Cylinder Pin
3	Spacer Sleeves
4	Pin Keeper
5	Strap
6	Bolt (hex head capscrew)
7	Lock Washer
8	Grease Fitting
9	Boom Bearings
10	Machine Bearings, where used
11	Inspection/Access Cover
12	Bolt (hex head capscrew)
13	Flat Washer
14	Port Block Assembly

Custom parts - call the Genesis Parts Department, 715-395-3488, for part numbers specific to your serial number.

PARTS

Third-Member Mount / Upper Head

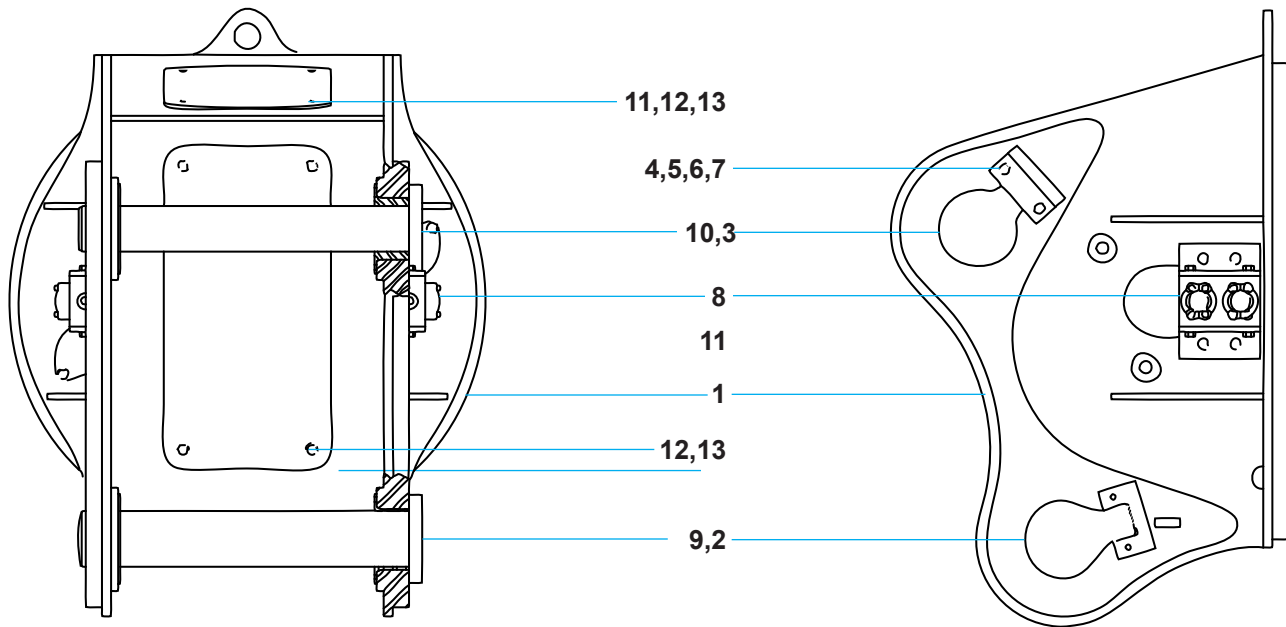

Item	Description
1	Upper Head
2	Stick Pin
3	Spacer Sleeves, where used
4	Pin Keeper
5	Strap
6	Bolt (hex head capscrew)
7	Lock Washer
8	Port Block Assembly
9	Bearings and/or Spacer Sleeves, where used
10	Cylinder Link Pin
11	Inspection/Access Cover
12	Bolt (hex head capscrew)
13	Flat Washer

Custom parts - call the Genesis Parts Department, 715-395-3488, for part numbers specific to your serial number.

PARTS

Single Guide Blade - Blades and Wear Parts

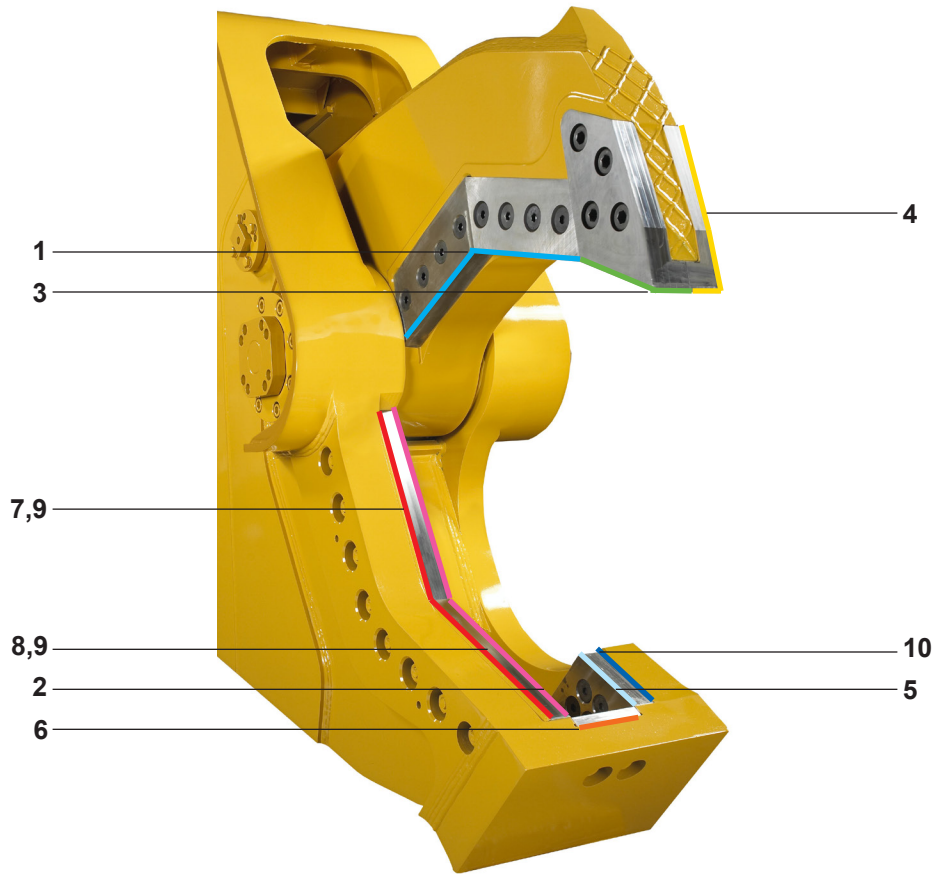

Item	Description	Qty	200		300		400		500	
			PN	Wet Torque (Nm/ft-lb)	PN	Wet Torque (Nm/ft-lb)	PN	Wet Torque (Nm/ft-lb)	PN	Wet Torque (Nm/ft-lb)
1	Upper Blades	2	4500397	354/256	1103534	1046/772	1103536	1046/772	1102939	2095/1545
2	Lower Blades	2	4500396	354/256	1103535	570/413	1103537	570/413	1103104	854/617
3	RH Tip Blade	1	4500394	433/320	1103538	698/515	1103538	698/515	1102832	1046/772
4	LH Tip Blade	1	4500395	433/320	1103539	698/515	1103539	698/515	1102833	1046/772
5	Guide Blade	1	4500398	354/256	1103540	570/412	1103540	570/412	1103334	854/617
6	Razor Blade	1	4500399 4500953*	433/320	1101955	698/515	1101955	698/515	1101957	1046/772
7	Primary Adjustment Plate	1	1103715		1103648		1103604		1103315	
8	Secondary Adjustment Plate	1	1103716		1103649		1103603		1103316	
9	Blade Shim Set	1	4500464		1103661		1103659		1103394	
10	Guide Shim Set	1	4500470		1103660		1103660		3100721	

* For use on Serial Number GXP200302 and GXP200303 only.

Replace adjustment plates when lost, damaged or extremely worn.

PARTS

Single Guide Blade - Blades and Wear Parts

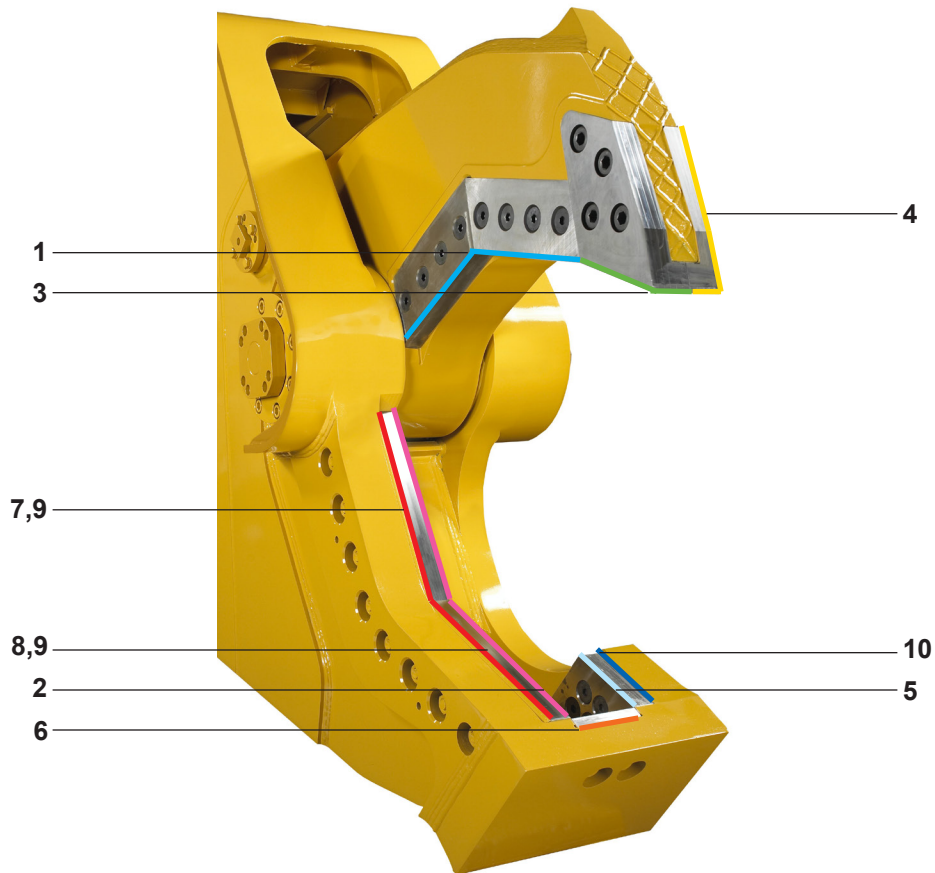

Item	Description	Qty	700		1000		1500	
			PN	Wet Torque (Nm/ft-lb)	PN	Wet Torque (Nm/ft-lb)	PN	Wet Torque (Nm/ft-lb)
1	Upper Blades	2	1102512	2095/1545	1103104	2095/1545	1103104	2095/1545
2	Lower Blades	2	1103116	854/617	1103117	854/617	1103117	854/617
3	RH Tip Blade	1	1102832	1046/772	1102832	1046/772	1103415	1046/772
4	LH Tip Blade	1	1102833	1046/772	1102833	1046/772	1103416	1046/772
5	Guide Blade	1	1103334	854/617	1103334	854/617	1103334	854/617
6	Razor Blade	1	1101957	1046/772	1101957	1046/772	1102499	1046/772
7	Primary Adjustment Plate	1	1103175		1103242		1103242	
8	Secondary Adjustment Plate	1	1103174		1103241		1103241	
9	Blade Shim Set	1	1103256		1103257		1103257	
10	Guide Shim Set	1	3100721		3100721		3100721	

Replace adjustment plates when lost, damaged or extremely worn.

PARTS

Dual Guide Blade - Blades and Wear Parts

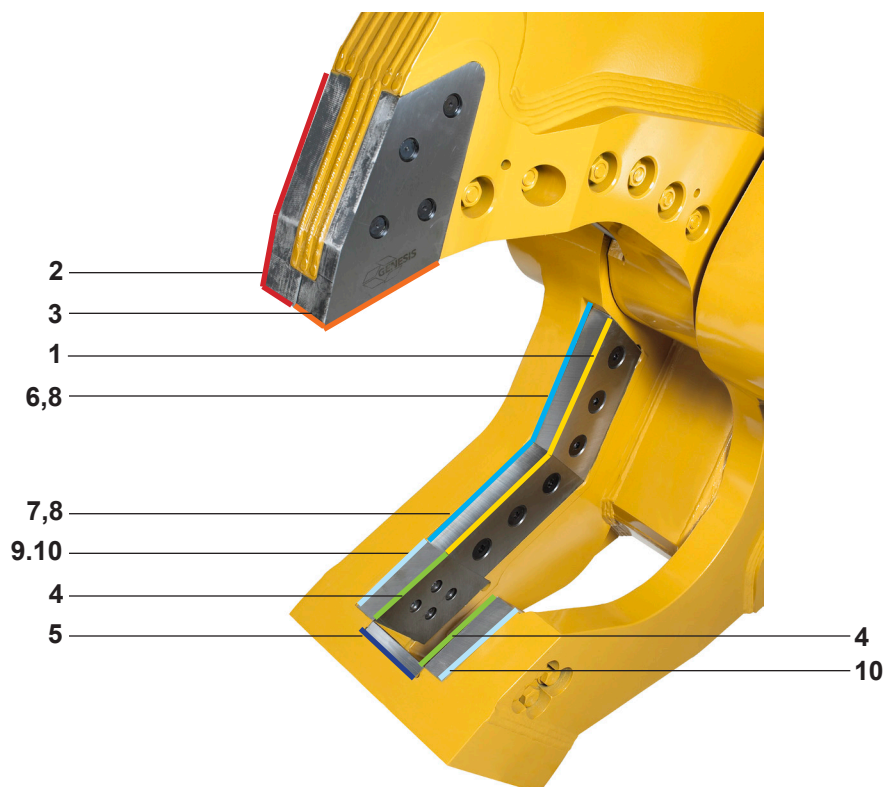

1 also on opposite side of upper jaw

Item	Description	Qty	400		500/660		700		990	
			PN	Wet Torque (Nm/ft-lb)	PN	Wet Torque (Nm/ft-lb)	PN	Wet Torque (Nm/ft-lb)	PN	Wet Torque (Nm/ft-lb)
1	Cutting Blades	4	1103536	570/412	1102939	854/617	1102512	854/617	1102512	854/617
2	RH Tip Blade	1	1103538	1046/772	1102832	2095/1545	1102832	2095/1545	1103415	2095/1545
3	LH Tip Blade	1	1103539	1046/772	1102833	2095/1545	1102833	2095/1545	1103416	2095/1545
4	Guide Blades	2	1103540	698/515	1103334	1046/772	1103334	1046/772	1103334	1046/772
5	Razor Blade	1	1101955	698/515	1101957	1046/772	1101957	1046/772	1102499	1046/772
6	Primary Adjustment Plate	1	1104649		1104357		1104579		1104579	
7	Secondary Adjustment Plate	1	1104650		1104358		1104578		1104578	
8	Blade Shims	2	1104652		1104515		1104648		1104648	
9	Guide Adjustment Plate	1	1104654		1104361		1104361		1104361	
10	Guide Shims	1	1103660		3100721		3100721		3100721	

Replace adjustment plates when lost, damaged or extremely worn.

PARTS

Dual Guide Blade - Blades and Wear Parts

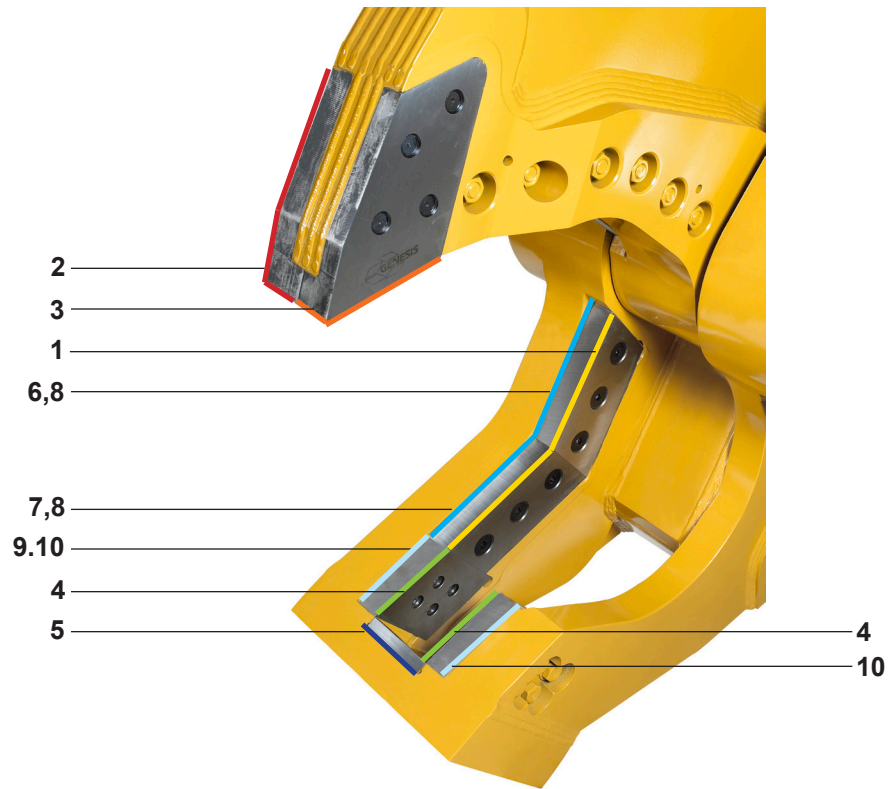

1 also on opposite side of upper jaw

Item	Description	Qty	1000		1200/1500		2500	
			PN	Wet Torque (Nm/ft-lb)	PN	Wet Torque (Nm/ft-lb)	PN	Wet Torque (Nm/ft-lb)
1	Cutting Blades	4	1103104	854/617	1103104	854/617	1104010	2979/2150
2	RH Tip Blade	1	1102832	2095/1545	1103415	2095/1545	1104011	2095/1545
3	LH Tip Blade	1	1102833	2095/1545	1103416	2095/1545	1104012	2095/1545
4	Guide Blades	2	1103334	1046/772	1103334	1046/772	1104013	3644/2688
5	Razor Blade	1	1101957	1046/772	1102499	1046/772	1104073	1046/772
6	Primary Adjustment Plate	1	1104443		1104443		1104195	
7	Secondary Adjustment Plate	1	1104445		1104445		1104196	
8	Blade Shims	2	1103394		1103394		1104071	
9	Guide Adjustment Plate	1	1104361		1104361		1104197	
10	Guide Shims	1	3100721		3100721		1104072	

Replace adjustment plates when lost, damaged or extremely worn.

PARTS

Pivot Group and AutoGuide

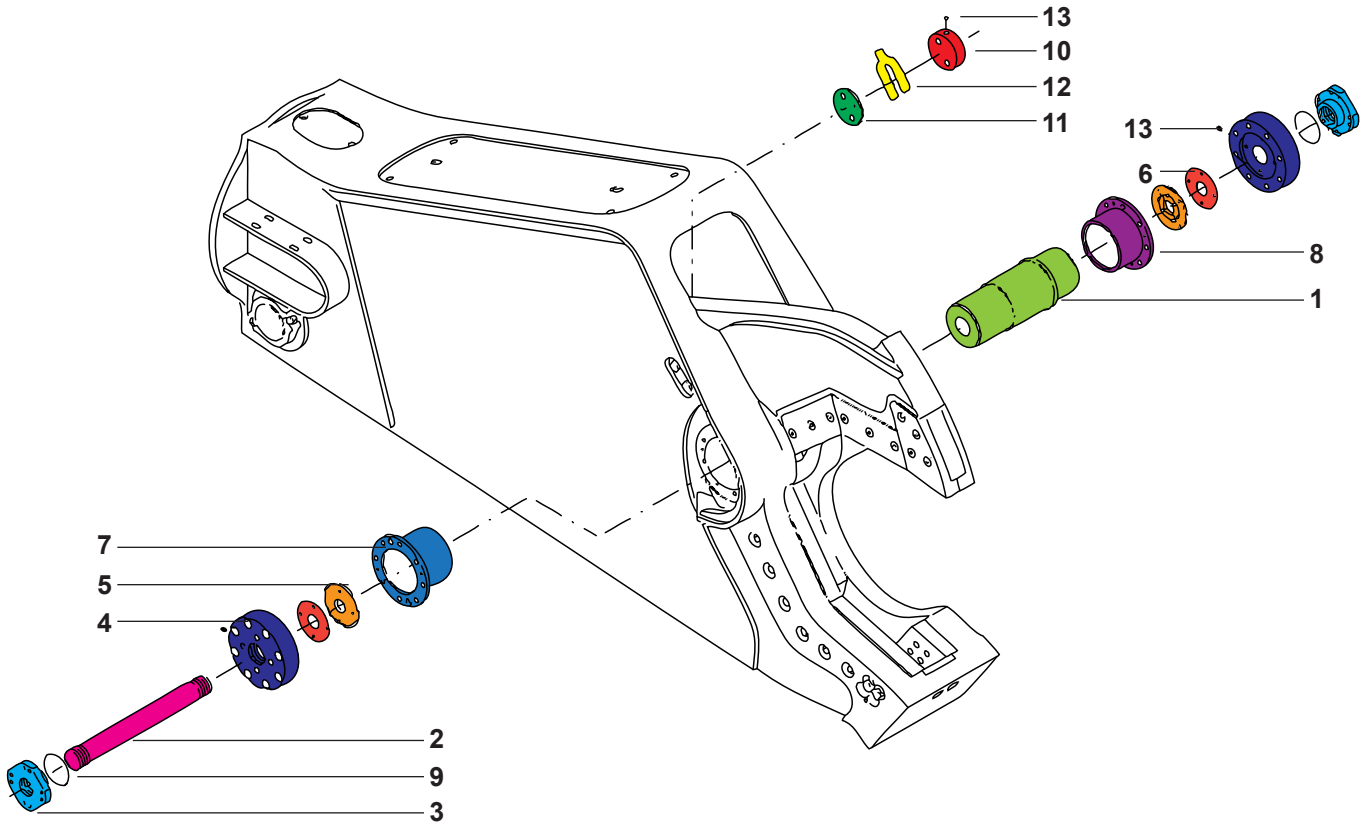

Item	Description	Qty	200	300/400	500/660/ 700/1000	990	1200/1500	2500
1	Shaft	1	1103879	1100245	1103124	1104797	1101639	1104050
2	Tie Rod	1	n/a	1100184	1103792	1104801	1101640	1104078
3	Tie Rod Nut	2	n/a	1100181	1102446	1101644	1101644	1104081
4	End Caps	2	3100132	1100179	1102444	1101647	1101647	1104075
5	Thrust Washer	2	n/a	1100061	1102442	1101646	1101646	1104048
6	Thrust Washer Shims	2	3100712	1100086	1102448	1101649	1101649	1104049
7	RH Bearing	1	3100130	1100177	1103125	1104799	1101650	1104052
8	LH Bearing	1	3100131	1100178	1103126	1104800	1101651	1104053
9	O-Ring	2	S0190447	n/a	S0190244	n/a	n/a	S0190254
10	AutoGuide	1	n/a	1103373	1103373	1103373	1103373	1104207
11	Adjustment Plate	1	n/a	1103375	1103375	1103375	1103375	1104209
12	Puck Shims	1	n/a	1103435	1103435	1103435	1103435	1104453
13	Grease Fitting	3	6200002	6200002	6200002	6200002	6200002	6200002

PARTS

Cylinder Assembly

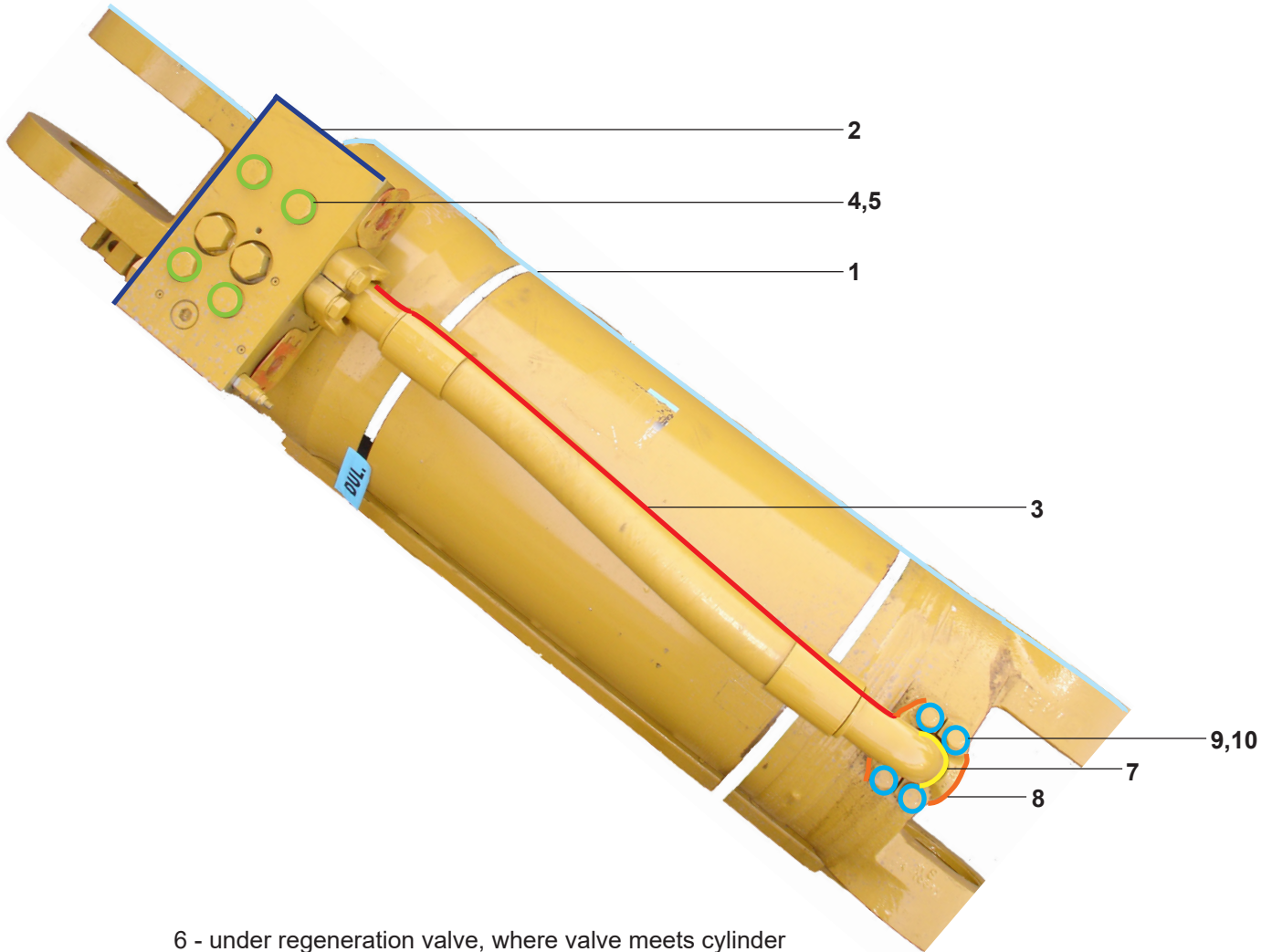

6 - under regeneration valve, where valve meets cylinder

Item	Description	Qty	200	300	400	500	660/700	990/1000	1200	1500
1	Cylinder	1	6300155	6300528	6300529	6300635	6300636	6300637	6300531	6300683
2	Regeneration Valve*	1	6300193	6300830 6300524	6300830 6300524	6300830 6300524	6300830 6300525	6300830 6300525	6300830 6300525	6300830 6300525
3	Hose	1	1200108	3100280	1200106	1200175	1200049	1200181	1200110	1200110
4	Regen Bolts	4	F0116180	F0124180	F0124180	F0124180	F0124180	F0124180	F0124180	F0124180
5	Regen Washers	4	F1201630	F1202444	F1202444	F1202444	F1202444	F1202444	F1202444	F1202444
6	Regen O-Ring*	1	S0190222	6300638 S0190225	6300638 S0190225	6300638 S0190225	6300638 S0190225	6300638 S0190225	6300638 S0190225	6300638 S0190225
7	Hose O-Rings	2	S0190225	S0190228	S0190228	S0190228	S0190228	S0190228	S0190228	S0190228
8	Split Flanges	4	H0262150	H0662200	H0662200	H0662200	H0662200	H0662200	H0662200	H0662200
9	Hose Bolts	8	F0116060	F0120070	F0120070	F0120070	F0120070	F0120070	F0120070	F0120070
10	Hose Washers	8	F1401628	F1402000	F1402000	F1402000	F1402000	F1402000	F1402000	F1402000

*Genesis uses regeneration valves from two sources.
For more information, see Hydraulic/Rotation Maintenance.

PARTS

Rotation Drive System GXP 200 & 300

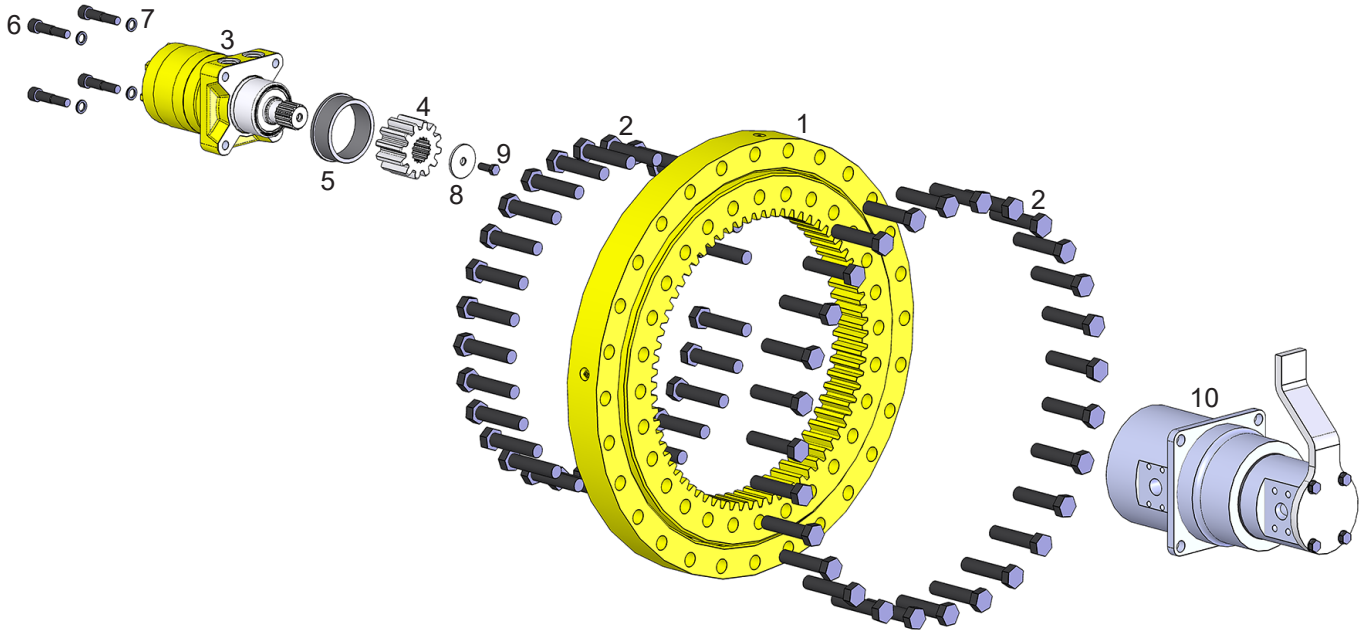

Item	Qty	Part Number	
		GXP 200 & 300	Description
1	1	6100092	Bearing Slewing
2	66	F0120100	Hex Head Capscrew M20 x 2.50 x 100
3	1	6380084	Motor
4	1	3101225	Pinion
5	1	1107014	Mach Spacer
6	4	1108183	Mach Bolt Socket Head Capscrew
7	4	F1900050	Washer Nord Lock
8	1	3101226	Mach Washer Motor Pinion
9	1	F023100	Hex Head Capscrew $\frac{3}{8}$ - 16 x 1
10	1	6350066	Assy Swivel Manifold

PARTS

Rotation Drive System

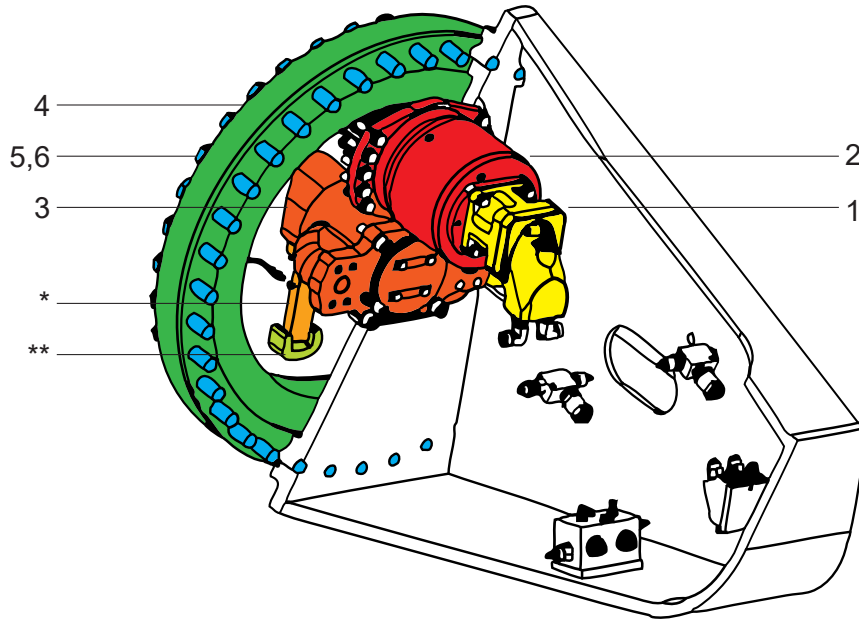

* Torque Arm, Sub-component of Swivel Assembly

** Torque Arm Stop, Sub-component of Swivel Assembly

Item	Description	400/500/660	700/990/1000	1200/1500	2500
1	Gear Motor Piston Motor	6300420 6300549	6300466 6300549	6300466	6300466
2	Gearbox	6300445	6300446	6300446	6300446
3	Swivel Assembly	5410012	5410010	5410010	5410010
4	Rotation Bearing	6300429	6300430	6300556	6300552
5	Bolts* (qty)	F0127130 (60)	F0130150 (71)	F0213700 (80)	F0215900 (76)
6	Washers	F1202750	F1203056	F1300125	F1300150

* GXP 400 - 600 M27 - 3 x 130, GXP 700 - 1000 M30 - 3.5 x 150, GXP 1200 & 1500 1¼ - 7 x 7, GXP 2500 1½ - 6 x 9



Gear Motor

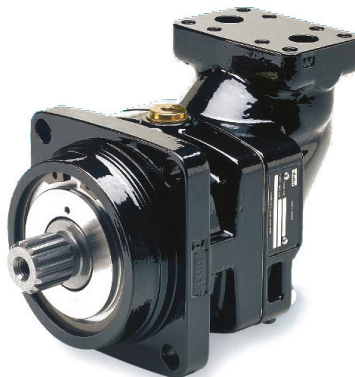

Piston Motor



Gerotor Motor (200/300)

BOLT TORQUE SPECIFICATIONS

Reference the product Thread Treatment Diagrams on page 80 to determine whether to use wet or dry torque values for specific bolts.

Reference Procedures on page 81 for threadlocker or anti-seize application and bolt and bolt hole cleaning.

Prior to torquing, clean all bolt holes, bolts and nuts to remove dirt, grease and oil, and identify bolt type.

Never re-torque bolts that use Loctite. If a bolt becomes loose or damaged after the initial use when Loctite was applied and the bolt was torqued, the bolt must be replaced.

Never break tightened bolts loose with a torque wrench. Doing so may break the torque wrench or take it out of calibration.

Torque wrenches should be calibrated on an annual basis.

When using a torque multiplier with a torque wrench, incorrect settings will be multiplied by the ratio of the torque wrench.

Never use an impact driver on a torque multiplier.

THREAD TREATMENT DIAGRAM

Mobile Shears

Use this diagram to determine what thread treatment, if any, is required for each fastener.

For thread treatment application procedures, see page 81. For prescribed torque values, see page 83.

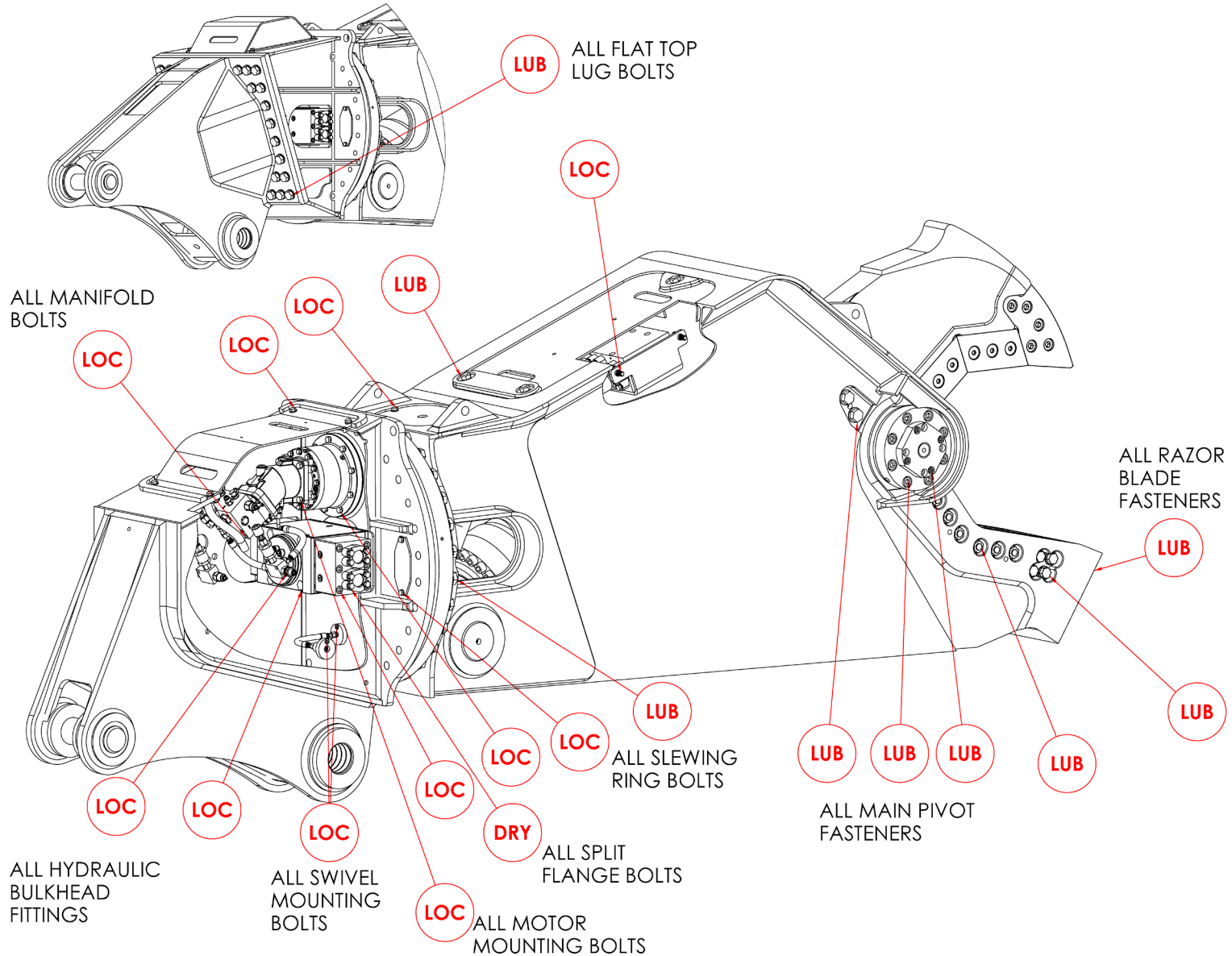

PROCEDURES

Reference the product Thread Treatment Diagrams on page 80 to determine which of the following procedures is required.

Cleaning

To ensure proper performance of thread treatment and accurate torque values, clean and degrease **all internal and external threads** prior to application of threadlocker, anti-seize or primer and before installation of hardware.

- Ensure both internal and external threads are free of dirt or debris.
- Use brake cleaner or similar cleaning solvent on all threads to remove any grease or oil.
- Allow threads to dry.

NOTICE

Failure to properly clean threads will cause threadlocker, primer, and/or anti-seize to not properly cure!

LOC

Threadlocker

For bolted connections requiring threadlocker, use **Loctite 263** or equivalent applied using the following procedure:

- Clean and degrease all threads.
- For thru holes or nuts, apply threadlocker to bolt threads.
- For blind holes, apply stripe of threadlocker along the length of the hole (applying to the bolt can cause escaping air to remove threadlocker as the bolt is inserted).
- Torque bolt to specified **Wet Torque Value**, see page 83.

For threaded hydraulic fitting connections, use **Loctite 5452** or equivalent thread sealant in conjunction with **Loctite 7471** primer using the following procedure:

- Clean and degrease all threads.
- Apply Loctite 7471 primer to both external and internal threads and allow to dry.
- Apply threadlocker to 360 degrees of the threads on the male fitting, ensuring adequate coverage.
- Assemble fitting per directions in operator's manual.
- For O-ring boss and flat face O-ring connections, torque fittings to values specified on page 84.

Threadlocker

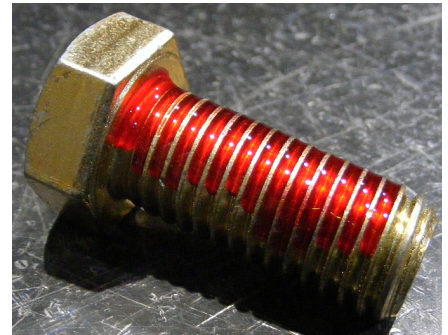

Blind Hole

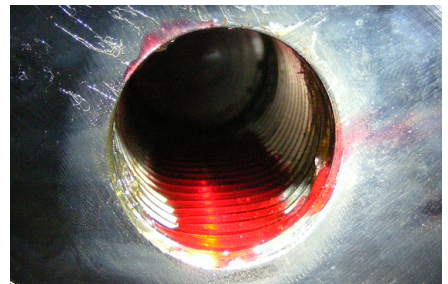

Hydraulic Fitting



PROCEDURES

LUB

Anti-Seize

For bolted connections requiring anti-seize lubrication, use **Loctite LB8008** or equivalent using the following procedure:

- Clean and degrease all threads.
- Apply thin coat of anti-seize to internal and external threads and under bolt head and/or nut, ensuring complete coverage.
- Torque bolt to specified **Wet Torque Value**, see page 83.

Anti-Seize







DRY

No Thread Treatment

- Clean and degrease all threads.
- Torque bolt to specified **Dry Torque Value**, see page 83.

BOLT TORQUE SPECIFICATIONS

Dry Torque Values					
		Hex/Socket Head		Flat Head	
					
Fastener Grade	Size x Pitch	Nm	Ft-lb	Nm	Ft-lb
CL 10.9	M8 x 1.25	35	26	27	20
	M10 x 1.50	71	53	58	42
	M12 x 1.75	124	92	101	73
	M14 x 1.50	200	148	163	118
	M14 x 2.00	200	148	163	118
	M16 x 2.00	311	230	254	184
	M20 x 1.50	610	450	498	360
	M20 x 2.50	608	449	497	359
	M24 x 3.00	1054	778	861	622
	M27 x 3.00	1543	1138	1260	910
	M30 x 3.50	2095	1545	1712	1236
	M36 x 4.00	3659	2699	2991	2159
8	1/4-20	14	11	11	8
	5/16-18	32	24	26	19
	3/8-16	59	44	48	35
	7/16-14	94	70	77	56
	1/2-13	143	106	116	84
	1/2-20	162	120	133	96
	5/8-11	287	212	234	169
	3/4-10	509	376	415	300
	7/8-9	821	606	670	484
	1.00-8	1232	909	1007	727
	1.00-14	1383	1020	1130	816
	1.25-7	2463	1817	2013	1453
8/L9	1.50-6	4287	3162	3504	2529

Wet Torque Values					
		Hex/Socket Head		Flat Head	
					
Fastener Grade	Size x Pitch	Nm	Ft-lb	Nm	Ft-lb
CL 10.9	M8 x 1.25	29	22	23	17
	M10 x 1.50	61	45	49	36
	M12 x 1.75	105	78	85	62
	M14 x 1.50	150	111	121	88
	M14 x 2.00	170	126	138	100
	M16 x 2.00	265	196	216	156
	M20 x 1.50	456	337	372	269
	M20 x 2.50	517	382	422	305
	M24 x 3.00	894	660	731	528
	M27 x 3.00	1312	968	1072	774
	M30 x 3.50	1779	1312	1453	1049
	M36 x 4.00	3110	2294	2542	1835
8	1/4-20	13	10	11	8
	5/16-18	27	20	22	16
	3/8-16	50	37	40	29
	7/16-14	80	59	65	47
	1/2-13	122	90	99	72
	1/2-20	138	102	112	81
	5/8-11	244	180	199	144
	3/4-10	433	320	354	256
	7/8-9	698	515	570	412
	1.00-8	1046	772	854	617
	1.00-14	1175	867	960	693
	1.25-7	2095	1545	1712	1236
8/L9	1.50-6	3644	2688	2979	2150

O-RING BOSS & FLAT FACE O-RING TORQUE SPECIFICATIONS

O-Ring Boss Torque Values		
Size Dash	Nm	Ft-lb
-4	22	16
-5	27	20
-6	36	26
-8	83	60
-10	110	80
-12	187	135
-14	249	180
-16	304	220
-20	387	280
-24	498	360

Flat Face O-Ring Torque Values		
Size Dash	Nm	Ft-lb
-4	18	13
-6	30	22
-8	60	44
-10	85	62
-12	121	88
-14	121	88
-16	160	116
-20	213	154
-24	274	198

BOLT DRIVE SPECIFICATIONS

Thread Size x Pitch	Hex Head	Socket Head	Flat Head
			
Wrench/Drive Size			
M8 x 1.25	13mm	6mm	5mm
M10 x 1.50	17mm	8mm	6mm
M12 x 1.75	19mm	10mm	8mm
M14 x 1.50	22mm	12mm	10mm
M14 x 2.00	22mm	12mm	10mm
M16 x 2.00	24mm	14mm	10mm
M20 x 1.50	30mm	17mm	12mm
M20 x 2.50	30mm	17mm	12mm
M24 x 3.00	36mm	19mm	14mm
M27 x 3.00	41mm	19mm	-
M30 x 3.50	46mm	22mm	-
M36 x 4.00	55mm	27mm	-
1/4-20	7/16"	3/16"	5/32"
5/16-18	1/2"	1/4"	3/16"
3/8-16	9/16"	5/16"	7/32"
7/16-14	5/8"	3/8"	1/4"
1/2-13	3/4"	3/8"	5/16"
1/2-20	3/4"	3/8"	5/16"
5/8-11	15/16"	1/2"	3/8"
3/4-10	1-1/8"	5/8"	1/2"
7/8-9	1-5/16"	3/4"	9/16"
1.00-8	1-1/2"	3/4"	5/8"
1.00-14	1-1/2"	3/4"	5/8"
1.25-7	1-7/8"	7/8"	7/8"
1.50-6	2-1/4"	1"	1"

TOOL LIST

The following tools are available for purchase from Genesis. This list may not include every tool used for this attachment, such as those that would also commonly be used for maintaining an excavator.

Part Number	Description
6900001	Service tool kit - includes part numbers 6900002 through 6900024
6900002	1-1/2" 12-point socket, 1" drive
6900003	1-5/16" 12-point socket, 1" drive
6900004	5/8" impact hex bit socket, 3/4" drive
6900005	3/4" impact hex bit socket, 3/4" drive
6900006	3/4" drive female to 1" drive male adapter
6900007	1-1/4" combo wrench
6900008	Jet needle scaler
6900009	17mm socket, 3/4" drive, metric impact
6900010	Torque multiplier, 2000 ft/lb
6900011	3/4" drive torque wrench, 600 ft/lb
6900012	26" male/female ratchet, 1" drive
6900013	30" ratchet, 1" drive
6900014	5/16" LA hex key
6900015	1-5/16" combo wrench
6900016	7/8" combo wrench
6900017	1-1/8" combo wrench
6900018	40mm 6-point impact socket, 3/4" drive
6900019	46mm 6-point impact socket, 3/4" drive
6900020	Tool box
6900021	7/8" impact hex bit socket, 3/4" drive
6900022	1-1/2" 6-point socket, 1" drive
6900023	7/8" impact hex bit socket, 1" drive
6900024	36mm 6-point impact socket, 1" drive

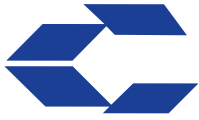

GENESIS®

The Promise of Performance.

CONTACT INFORMATION

Genesis Attachments

1000 Genesis Drive
Superior, WI 54880 USA

Toll Free: 888-SHEAR-IT
(888-743-2748)

Phone: 715.395.5252

E-mail:
info@genesisattachments.com

Europe/Africa/Middle East Genesis GmbH

Teramostrasse 23
87700 Memmingen, Germany

Phone: +49 83 31 9 25 98 0

Fax: +49 83 31 9 25 98 80

genesis-europe.com

E-mail:
info@genesis-europe.com

Asia Pacific Representative Office

24 Upper Serangoon View #12-28
Singapore 534205

Phone: +65 9673 9730

E-mail:
tchoo@genesisattachments.com

Central America & Colombia

Cra 13A #89-38 / Ofi 613
Bogota, Colombia

Phone: +57 1 610 8160 / 795 8747

E-mail:
contact@themsagroup.com

View and download all manuals: genesisattachments.com/manuals
Patents: genesisattachments.com/products/patents

Rev. 3-26-25