

Versi Pro 07 (GVP 07)

SAFETY & OPERATOR'S MANUAL



CONTACT INFORMATION

Genesis Attachments

1000 Genesis Drive
Superior, WI 54880 USA

Toll Free: 888-SHEAR-IT
(888-743-2748)

Phone: 715.395.5252

E-mail:
info@genesisattachments.com

Europe/Africa/Middle East Genesis GmbH

Teramostrasse 23
87700 Memmingen, Germany

Phone: +49 83 31 9 25 98 0
Fax: +49 83 31 9 25 98 80
genesis-europe.com

E-mail:
info@genesis-europe.com

Asia Pacific Representative Office

24 Upper Serangoon View #12-28
Singapore 534205

Phone: +65 9673 9730

E-mail:
tchoo@genesisattachments.com

Central America & Colombia

Cra 13A #89-38 / Ofi 613
Bogota, Colombia

Phone: +57 1 610 8160 / 795 8747

E-mail:
contact@themsagroup.com

View and download all manuals: genesisattachments.com/manuals
Patents: genesisattachments.com/products/patents

PREFACE

To ensure years of safe, dependable service, only trained and authorized persons should operate and service your Genesis attachment. It is the responsibility of the product's owner to ensure the operator is trained in the safe operation of the product and has available this manual for review. It is the responsibility of the operator and maintenance personnel to read, fully understand and follow all operational and safety-related instructions in this manual. The attachment should not be operated until you have read and fully understand these instructions. Always use good safety practices to protect yourself and those around you.

Important

This operator's manual must accompany the attachment at all times and be readily available to the operator.

Manual Replacement

Should this manual become damaged or lost or if additional copies are required, immediately contact any authorized Genesis dealer or the Genesis Service Department at 888-743-2748 or 715-395-5252 for a replacement.

Registration Form

The Warranty Registration Form must be filled out by the dealer or customer and returned to Genesis indicating the date the attachment went into service.

Possible Variations

Genesis cannot anticipate every possible circumstance that might involve a potential hazard as the owner's requirements and equipment may vary. Therefore, the warnings in this publication and on the product may not be all-inclusive, and you must satisfy yourself that the procedure, application, work method or operating technique is safe for you and others before operating.

Public Notice

Genesis reserves the right to make changes and improvements to its products and technical literature at any time without public notice or obligation. Genesis also reserves the right to discontinue manufacturing any product at its discretion at any time.

Warranty

All work or repairs to be considered for warranty reimbursement must be pre-authorized by the Genesis Service Department. Any alterations, modifications or repairs performed before authorization by the Genesis Service Department will render all warranty reimbursement consideration null and void without exception. See page 48 for Warranty Claim Procedures.

Improper operation or improperly performed maintenance may render any warranty null and void.

TABLE OF CONTENTS

CONTACT INFORMATION	2
PREFACE	3
Important	3
Manual Replacement	3
Registration Form	3
Possible Variations	3
Public Notice	3
Warranty	3
SAFETY STATEMENTS	7
OPERATIONAL SAFETY	8
Read Manual Before Operating or Maintaining the Attachment	8
Personal Protection	8
Know Your Equipment	8
Before Operating	8
Check the Equipment	9
Stability	9
Know the Work Area	10
Starting Procedure	10
Place the Load Safely	10
Safely Operate Equipment	11
Transporting the Attachment	12
Equipment Condition	12
Working Overhead	12
Power Lines	12
Use Care with Hydraulic Fluid Pressure	13
Prioritized Oil Flow	14
Emergency Situations	14
Unsafe Conditions	14
Crystalline Silica Dust	14
Prop. 65 Warning for California Residents	14
Process Material Safely	15
Lift the Load Safely	15
Place the Load Safely	15
ATTACHMENT MARKINGS	16
ATTACHMENT INSTALLATION	17
Electric Installation for Electric Over Hydraulic Option	17
Versi Pro Standard Eight-Pin Connection	17
Hydraulic Installation for Fully Hydraulic Option	17
HYDRAULIC START-UP	18
Start-up Procedure:	18
GENERAL OPERATION INSTRUCTIONS	19
Start-up	19
Efficient and Productive Operation	19
COMMON OPERATIONAL CONCERNS	20
Cutting Larger Materials	20
Chatter While Cutting	20

TABLE OF CONTENTS

MAINTENANCE SAFETY	21
MAINTENANCE SCHEDULE	23
Eight-Hour Checklist	23
Long-term Maintenance	23
BOLT TORQUE SPECS	24
LUBRICATION POINTS	25
JAW SET CHANGE-OVER	26
Jaw Removal	26
Jaw Installation	26
JAW SET MAINTENANCE	27
Pivot Group Adjustment Rev A	27
SHEAR JAW SET MAINTENANCE	28
Daily Maintenance Checks	28
Piercing Tip	28
Piercing Tip Replacement	28
Wear Plate Replacement	29
Guide Blades	30
Guide Blade Shimming	30
Guide Blade Rotation	31
Guide Blade Replacement	31
Cutting Blades	31
Cutting Blade Removal	31
Blade Bolts	31
Cutting Blade Rotation	32
Cutting Blade Gap Adjustment & Shimming	32
CONCRETE CRACKER JAW SET MAINTENANCE	33
Tooth Replacement Procedure	33
WIRE CUTTER JAW SET MAINTENANCE	34
Wire Cutter Jaw Removal	35
Wire Cutter Jaw Installation	37
GRAPPLE JAW SET MAINTENANCE	40
Tip Replacement Procedure	40
GENERAL WELDING GUIDELINES	41
Welding Ground Clamp	41
Welding Rules	41
BUILD-UP	42
HARD-SURFACING	43
WELDING MAINTENANCE	44
Hard-Surfacing Patterns	44

HYDRAULIC / ROTATION MAINTENANCE	45
Mounting Bolts.....	45
Bolt Torque.....	45
Grease Daily.....	45
Stand Clear.....	45
Rotate After Greasing.....	45
Grease Temperatures.....	45
Hydraulic Requirements.....	45
Electrical Requirements.....	45
TROUBLE-SHOOTING GUIDE	46
Jaw Set.....	46
Rotator.....	47
WARRANTY	48
Claim Procedure.....	48
Blade Warranty.....	48
PARTS ORDER POLICY AND PROCEDURE	49
Parts Orders Should Include.....	49
Placing Orders.....	49
Part Numbers.....	49
Shipping.....	49
Invoices.....	49
Returns.....	49
Warranty Returns.....	49
PARTS ORDER FORM	50
CONTACT INFORMATION	51

NOTICE

For bolt torque specs, see the Genesis Fastener Manual.
genesisattachments.com/manuals

SAFETY STATEMENTS



This symbol by itself or used with a safety signal word throughout this manual is used to call attention to instructions involving your personal safety or the safety of others. Failure to follow these instructions can result in injury or death.



This statement is used where serious injury or death will result if the instructions are not followed properly.



This statement is used where serious injury or death could result if the instructions are not followed properly.



This statement is used where minor or moderate injury could result if the instructions are not followed properly.

NOTICE

This statement is used where property damage could result if the instructions are not followed properly.

OPERATIONAL SAFETY

Read Manual Before Operating or Maintaining the Attachment



Read this manual before attempting to operate the attachment. This operator's manual should be regarded as part of the attachment. For proper installation, operation and maintenance of the attachment, operators and maintenance personnel must read this manual.



WARNING

Serious injury or death could result if appropriate protective clothing and safety devices are not used.

Personal Protection

Use protective clothing and safety devices appropriate for the working conditions. These may include but are not limited to:

- ✓ Hard hat
- ✓ Safety glasses, goggles or face shield
- ✓ Hearing protection
- ✓ Safety shoes
- ✓ Heavy gloves
- ✓ Reflective clothing
- ✓ Respirator or filter mask



Safety matters

Know Your Equipment



Know your attachment's capabilities, dimensions and functions before operating. Inspect your attachment before operating and never operate an attachment that is not in proper working order. Remove and replace any damaged or worn parts.

Before Operating

- ✓ Warn all others in the area that you are about to start operation.
- ✓ Perform the Check the Equipment steps outlined in this manual.
- ✓ Check underneath and around the machine. Make sure all personnel and equipment are clear from the area of operation and equipment movement. Check clearances in all directions, including overhead.
- ✓ Be properly seated in the operator's seat.
- ✓ Do not attempt to operate until you have read and fully understand this manual and the OEM manual for the carrier.

OPERATIONAL SAFETY

Check the Equipment

Before use, check the equipment to ensure it is in good operating condition.

Check the following:

- ✓ Grease fittings. Pump grease at all fitting locations, see page 25
- ✓ Hydraulic fluid level. Add hydraulic fluid as required.
- ✓ Hydraulic hoses and hose connections for wear or leaks. Repair or replace any damaged hoses or connections.
- ✓ All control levers for proper operation.
- ✓ Rotation bearing. Visually check for loose or damaged bolts. If repair is required, refer to qualified personnel.
- ✓ Grease rotation bearing and pinion gear.
- ✓ Check for loose or missing pin retaining bolts.
- ✓ Check cylinders for dents (barrel) or dings (rod).



**GOOD
CONDITION**



WARNING

Serious injury or death could result if warnings or instructions regarding carrier stability and the work area are not followed properly.

Stability

Your Genesis attachment is sized for carrier stability. However, improper operation, faulty maintenance or unauthorized modifications may cause instability.

- ✓ Know the working ranges and capacities of the carrier to avoid tipping.
- ✓ Use the recommended carrier counter weight.

The following conditions affect stability:

- Ground conditions
- Grade
- Weight of attachment
- Contents of attachment
- Operator judgement



For greater stability, knuckle the attachment to bring the load closer to the center of rotation (center of gravity) while lifting. Use extra caution during reaching to avoid tipping.

OPERATIONAL SAFETY

Know the Work Area

Check clearances in the work area. Keep all bystanders at a safe distance. Do not work under obstacles. Always check your location for overhead and buried power lines or other utilities before operation.

Check ground conditions. Avoid unstable or slippery areas. Position the carrier on firm level ground. If level ground is not possible, position the carrier to use the attachment to the front or back of the carrier. Avoid working over the side of the carrier.

To reduce the risk of tipping and slipping, never park on a grade exceeding 10% (one-foot rise over the span of a ten-foot run).

Starting Procedure

Before operating, walk completely around the equipment to make certain no one is under it, on it or close to it. Keep all bystanders at least 75 feet away from the area of operation and equipment movement. Let all other workers and bystanders know you are preparing to start. DO NOT operate until everyone is clear.

Always be properly seated in the operator's seat before operating any carrier controls.

To start:

- ✓ Make sure all controls are in the center (neutral) position.
- ✓ Be properly seated.
- ✓ Slowly operate all functions to check for proper operation and to bleed air from the hydraulic system.

To shut down:

- ✓ Return your Genesis attachment to a rest position on the ground.
- ✓ Shut off the carrier engine.
- ✓ Work controls in all directions to relieve hydraulic pressure, per excavator manufacturer's instructions.



WARNING

Serious injury or death could result if warnings or instructions regarding safe operation are not followed properly.

Place the Load Safely

Do not move the attachment, or anything held in the jaws, over people, equipment or buildings. Do not throw or drop the contents. Operate the controls smoothly and gradually.

OPERATIONAL SAFETY

Safely Operate Equipment

Do not operate equipment until you are trained by a qualified operator in its use and capabilities.

See your carrier's manual for these instructions.

- ✓ Operate only from the operator's seat. Check the seat belt daily and replace if frayed or damaged.
- ✓ Do not operate this or any other equipment under the influence of drugs or alcohol. If you are taking prescription medication or over-the-counter drugs ask your medical provider whether you can safely operate equipment.
- ✓ Never leave equipment unattended with the engine running or with the attachment in a raised position. Apply the brakes before exiting the equipment.
- ✓ Do not exceed the lifting capacity of your carrier.
- ✓ Avoid conditions that can lead to tipping. The carrier can tip when operated on hills, ridges, banks and slopes. Avoid operating across a slope which could cause the carrier to overturn.
- ✓ Reduce speed when driving over rough terrain, on a slope, or when turning to avoid overturning the carrier.
- ✓ Never use the attachment as a work platform or personnel carrier.
- ✓ Keep all step plates, grab bars, pedals and controls free of dirt, grease, debris and oil.
- ✓ Never allow anyone to be around the equipment when it is operating.
- ✓ Do not operate poorly maintained or otherwise faulty equipment. Inform the proper authority and DO NOT resume operation until the problem has been fixed.
- ✓ Do not alter or remove any safety features.
- ✓ Know your work site safety rules as well as traffic rules and flow. When in doubt on any safety issue, contact your supervisor or safety coordinator for an explanation.
- ✓ A heavy load can cause equipment instability. Use extreme care during travel. Slow down on turns and watch out for bumps. The equipment may need additional counter-weights to counterbalance the weight of the attachment.



OPERATIONAL SAFETY

Transporting the Attachment

- ✓ Travel only with the attachment in a safe transport position to prevent uncontrolled movement. Drive slowly over rough ground and on slopes.
- ✓ When driving on public roads use safety lights, reflectors, Slow Moving Vehicle signs, etc., to prevent accidents. Check local government regulations that may affect you.
- ✓ Do not drive close to ditches, excavations, etc., as cave-in could result.
- ✓ Do not smoke when refueling the prime mover. Allow room in the fuel tank for expansion. Wipe up any spilled fuel. Secure cap tightly when done.

Equipment Condition

Never operate poorly maintained equipment. When maintenance is required, repair or replace parts immediately.



WARNING

Serious injury or death could result if warnings or instructions regarding working overhead are not followed properly.

Working Overhead

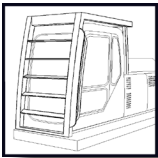

Avoid handling material overhead whenever possible. Safety glass and wire mesh cab guarding must be installed to protect the operator from flying debris that may be created during handling. Falling Object Protection Structures, or FOPS, are necessary for any application where material is to be handled overhead.



DANGER

Serious injury or death will result if warnings or instructions regarding power lines are not followed properly.

Power Lines

Do not operate the machine near energized power lines. All local, state/provincial and federal regulations must be met before approaching power lines, overhead or underground cables, or power sources of any kind with any part of the carrier or attachment. Always contact the appropriate utility when operating near power lines. The lines should be moved, insulated, disconnected or de-energized and grounded before operating in the area.



Current in high voltage lines may arc some distance from the wire to a nearby ground. Keep all parts of the machine at least 50 feet (16m) away from power lines.

OPERATIONAL SAFETY



WARNING

Serious injury or death could result if warnings or instructions regarding hydraulic fluid pressure are not followed properly.

Use Care with Hydraulic Fluid Pressure

Hydraulic fluid under pressure can penetrate the skin and cause serious injury or death. Hydraulic leaks under pressure may not be visible.

- ✓ Keep unprotected body parts, such as face, eyes and arms as far away as possible from a suspected leak. Flesh injected with hydraulic fluid may develop gangrene or other permanent injuries.
- ✓ If injured by injected fluid see a doctor immediately.
- ✓ Wear safety glasses and protective clothing and use a piece of cardboard or wood when searching for hydraulic leaks.

Do Not Use Your Hands!
See illustration below.

- ✓ Hydraulic oil becomes hot during operation. Do not let hydraulic oil or components contact skin, as it could cause severe burns. Allow hydraulic components to cool before working on them. Use appropriate protective clothing and safety equipment. If burned, seek immediate medical attention.

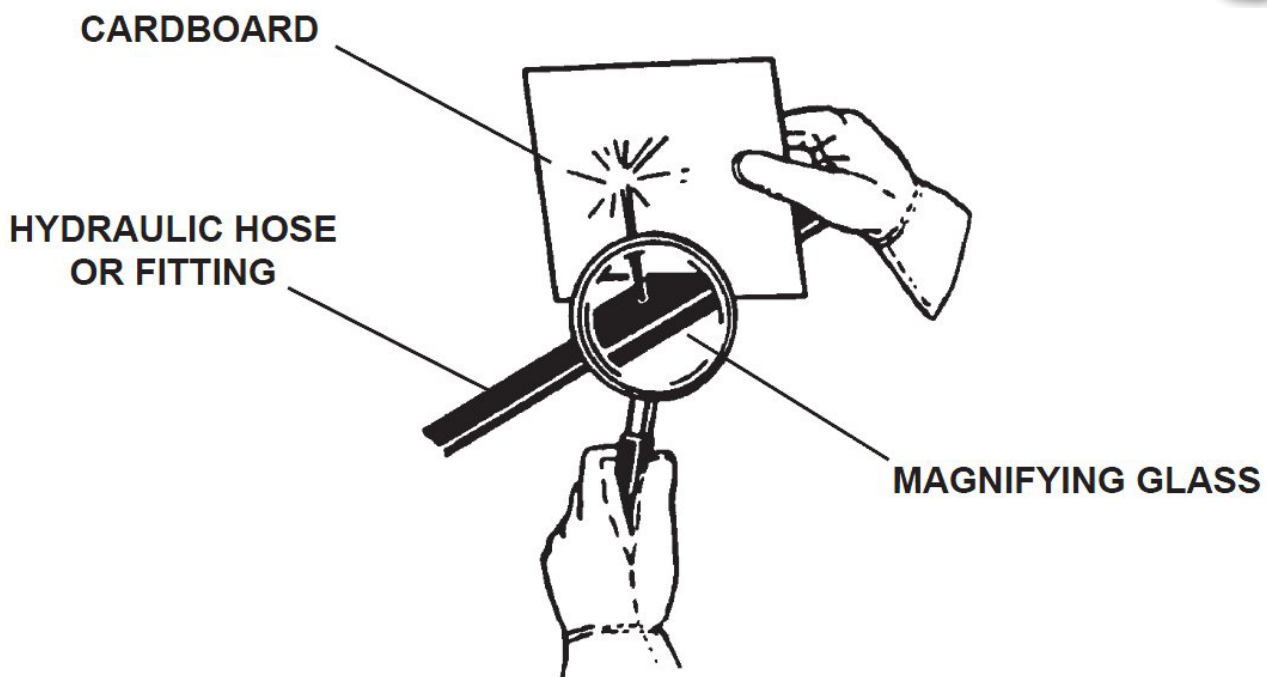

OPERATIONAL SAFETY

Prioritized Oil Flow

Equipment operators must ensure there is prioritized oil flow to the main valves in overhead operations or high reach conditions.

Emergency Situations

Always be prepared for emergencies. Make sure a fire extinguisher is available. Be familiar with its operation. Make sure to inspect and service the fire extinguisher regularly. Make sure a first aid kit is readily available.



Unsafe Conditions

Do not operate if an unsafe condition exists. Stop operation immediately, shut down the machine and report the unsafe condition to the proper authority. Equipment operation and maintenance practices directly affect your safety and the safety of those around you. Always use common sense while operating and be alert to unsafe conditions.

Crystalline Silica Dust

It is recommended to use dust suppression, dust collection and if necessary, personal protective equipment during the operation of any attachment that may cause high levels of dust.



DANGER

Exposure to respirable crystalline silica dust along with other hazardous dusts may cause serious or fatal respiratory disease.

IMPORTANT: Concrete and masonry products contain silica sand. Quartz, which is a form of silica and the most common mineral in the Earth's crust, is associated with many types of rock.

Some activities that may have silica dust present in the air include demolition, sweeping, loading, sawing, hammering, drilling or planing of rock, concrete or masonry.

It is recommended to use dust suppression (such as water) or dust collection (such as a vacuum) along with personal protective equipment if necessary during the operation of any attachment that may cause high levels of silica dust.



Prop. 65 Warning for California Residents



WARNING

This product may contain chemicals known to the State of California to cause cancer, birth defects, or other reproductive harm. For more information visit: P65Warnings.ca.gov

OPERATIONAL SAFETY



WARNING

Using your Genesis attachment in unauthorized applications may create an unsafe situation and will void the warranty.

Process Material Safely

- Do not process hardened steel material such as tool steel, railroad rail, axles, springs, machined parts or high-strength material. Hardened/high-strength material breaks, rather than shears, which may cause flying debris. It will also cause damaging decompression spikes to your Genesis attachment and base carrier hydraulic systems.
- Do not operate any functions of the carrier while cutting or crushing with your attachment, including boom and drive functions.
- Do not pull down structures with your Genesis attachment. Doing so may cause falling debris or material to break free and exceed the capacities of the carrier, causing a tipping hazard and rotation component failures.
- Do not use rotation to pry or break material. Doing so exerts high back-driving forces and spikes to the rotation circuit components that cannot be cushioned hydraulically. It may also cause motor and gearbox failures. The rotator should only be used for positioning an attachment.
- Do not process pressurized containers unless the main valve has been removed and you are absolutely certain the container is empty.
- Do not process spring loaded brake chambers and automotive struts as the release of compressed springs is extremely dangerous. Nothing made of spring material or containing springs should be processed.

Lift the Load Safely

- The hydraulic system has been preset and tested by your dealer. Do not alter hydraulic settings without consulting an authorized Genesis dealer or the Genesis Service Department. Doing so will void the warranty and may cause structural damage, accidents or tipping.
- Make sure the load is held securely in the jaws. Do not move a loaded attachment if load is loose or dangling. Make sure the load is pinched between the jaws – never cradle a load.
- For greater stability, knuckle the attachment to bring the load closer to the center of rotation (center of gravity) while lifting. Use extra caution during reaching to avoid tipping.

Place the Load Safely

- Do not move the attachment, or anything held in the jaws, over people, equipment or buildings. Place the load gently. Do not throw or drop the contents.
- Operate the controls smoothly and gradually. Jerky controls are hazardous and may cause damage to the carrier.
- Avoid fire hazards. Keep the area clean. Remove all flammable materials from the area during any welding or heating process. Have a fire extinguisher nearby and know how to use it.
- Never substitute pins or bolts. Use factory supplied pins. Replace all bolts with the same size and grade. Failure to do so may cause serious injury or death.
- Use your Genesis attachment only as directed in this manual. Do not use the attachment to lift and move other objects. Doing so may cause instability and tipping.

ATTACHMENT MARKINGS

Decals are necessary for safe operation and maintenance. To reorder, contact your Genesis dealer or call 715-395-5252.



ATTACHMENT INSTALLATION

Install the Versi Pro according to your carrier (skid steer or mini-excavator) OEM's standard bucket/attachment installation instructions.

Electric Installation for Electric Over Hydraulic Option

The Versi Pro 07 requires an electrical connection to the carrier - skid steer or mini-excavator. Carrier OEMs often provide an electrical connector near the hydraulic quick-couplers. Genesis provides a wiring harness to connect the Versi Pro to the carrier.

OR:

In the absence of an OEM-provided electrical connection, Genesis provides a complete control system including joystick handles available for purchase.

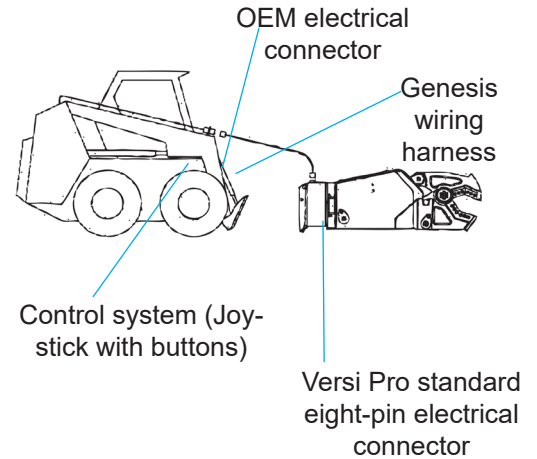

Versi Pro Standard Eight-Pin Connection

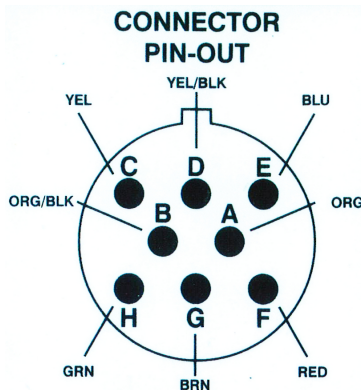

A	Jaw open
B	Jaw close
C	Rotate clockwise
D	Rotate counter-clockwise
E	Regen override
F	Keyed power
G	Unloader
H	Ground

Hydraulic Installation for Fully Hydraulic Option

The Versi Pro 07 is equipped with bulkhead connector fittings to enable the installation of hydraulic lines to supply hydraulic fluid to the shear jaw and rotation circuits.

This option requires that the machine is equipped with two (2) bi-directional flow hydraulic circuits equipped with port reliefs and anti-cavitation valves.

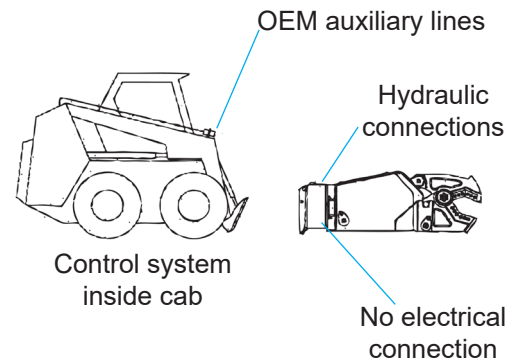

HYDRAULIC START-UP

The Genesis Versi Pro 07 Processor is designed to operate up to 3650 PSI. Due to these high pressures, it is important that air is bled from the attachment cylinder after installation. Failure to follow these procedures could result in cylinder seal damage and/or base machine hydraulic system damage.

Start-up Procedure:

- ✓ Check the base machine hydraulic reservoir for proper fluid level.
- ✓ The base machine hydraulic oil should be warmed up per the OEM procedures before hooking up the attachment.
- ✓
- ✓ Follow the OEM procedures for starting and warming in cold weather. Do not operate the attachment circuit during the warm-up period.
- ✓ After the base machine has reached normal operating temperature, set the engine to idle speed.
- ✓ The attachment must be vertical to bleed air from the cylinder.
- ✓ Slowly fill the bore end of the attachment cylinder to partially close the jaws. Do not allow the tank to run low - have someone watch the oil level gauge.

NOTICE

Do not fully extend or retract attachment cylinder with the first cycles.

- ✓ Slowly fill the rod end of the attachment cylinder to open the jaws. Use partial strokes extending and retracting, slowly working to full strokes.
- ✓ Stop and check the base machine hydraulic fluid level again to be sure there is still sufficient fluid. Fill the reservoir as needed. Note: the hydraulic fluid level should be checked with the attachment jaws open (cylinder retracted).
- ✓ Cycle the jaws five or six strokes before increasing to full operating pressure.

GENERAL OPERATION INSTRUCTIONS

Follow all rules and procedures outlined in the Operation Safety section under General Safety in this manual.

Use the attachment only as intended, in approved applications, as set forth in this manual.

Do not allow attachment, exposed cylinder rod or hoses to come into contact with any obstacles, buildings or the excavator.

The attachment is not intended to crush or break objects or structures by swinging or dropping the attachment.

Start-up

During initial operation and any time jaw maintenance has been performed, process thin and lighter material first to work-harden wear areas, developing a harder, more durable edge. This is also the most effective time to process materials such as sheet metal or wire. The new or repaired edges will cut more efficiently and be less likely to jam material between the blades.

NOTICE

When operating in temperatures below freezing, it is also important to process light materials first. This allows the attachment's structural material to warm up, preventing thermal cracking.

Efficient and Productive Operation

Operators should become accustomed to performing work in the most proficient manner possible.

When cutting, build up and cut out of small piles, keeping the surfaces of the attachment chin plate and upper jaw out of the dirt as much as possible. Dirt is much more abrasive than steel and needlessly increases build-up and hard-surfacing time and intervals.

It also helps to give yourself enough room to keep out of the way of other personnel and machines. Material should be picked from a pile and swung to the side and cut in a new area. This prevents redundant cutting of the same pieces and allows for the newly prepared material to be loaded out with another material handling machine.

Material processing areas should be as close as safely possible to the location for loading materials for transportation. Less time spent processing, loading and transporting materials greatly affects operational costs and productivity and dramatically reduces man hours, fuel costs and wear on equipment.

Operators should develop the habit of assessing materials to be processed and visualizing a starting and finishing point to use the fewest cuts possible. Excessive moving, positioning and handling cost time and money. Bringing the jaws to full open, when only partial jaw open is needed for a cut, wastes time and fuel, slows other excavator functions as well as causes needless wear to hydraulic components, hoses and O-rings. More efficient processing will extend the life of the attachment.

COMMON OPERATIONAL CONCERNS

Cutting Larger Materials

When cutting larger materials the attachment jaw stalls just before cutting.

Suspend the material on the prepared pile, open the jaw and position the material as close to the throat as possible. Without pushing down on the material with excavator force, rapidly close the jaw on the material. Using the speed of regeneration can improve performance when cutting larger materials.

Chatter While Cutting

If the attachment starts to chatter while cutting, back out of the cut and reposition at a different spot.

Chattering is an indication that material is jamming between the piercing blades and guide blades or between the upper and lower cutting blades. This indicates that blade maintenance needs to be performed immediately. Worn blades and improper blade gaps are usually the cause.

Insufficient piercing blade gaps will also cause this, as the blades and parent material of the jaws are subject to thermal expansion from cutting friction. The tighter the blades run, the hotter they get and the more they expand. Piercing blades and guide blades are the most susceptible to this and will show blue streaking on their corresponding faces. In some cases, they will get so hot that surface cracks and spidering occur. As this happens, it will spread the lower jaw and increase gaps between the primary and secondary blades, causing thin material to jam between them.

Another key area to watch is the opening between the guide blades. Be aware of material that may get into this opening before the piercing blade moves into this space, as it will be wedged between the piercing blades and guide blades.

Most jamming conditions can be prevented if the operator pays attention to the sound and vibration that is associated with a jam. Remember that because of the rod-to-bore ratios of displacement on the attachment's hydraulic cylinder piston, the attachment has half the force on jaw open compared to jaw close. So if the attachment is jamming while closing, it won't have enough retract force to open.

MAINTENANCE SAFETY

Only trained and authorized persons should perform maintenance on the attachment. To be qualified, you must understand the instructions in this manual, have training, and know the safety rules and regulations of the job site.

Do not alter the physical, mechanical or hydraulic operation of the attachment. Doing so may cause a dangerous situation for yourself and those around you and will void the warranty.

Do not attempt repairs you do not understand. If any questions arise regarding a safety or maintenance procedure, contact Genesis or your Genesis dealer.

Read this entire manual. All personnel must understand the maintenance and safety procedures.

Use factory authorized parts. The use of unauthorized parts may compromise safety, performance and durability of the attachment and may void the warranty.

Follow the daily checklist and maintenance schedules in this manual. Extreme conditions may dictate shorter maintenance intervals.

Do not exceed bolt torque specifications. See the Genesis Fastener Manual.

Do not weld on structural components without consulting Genesis. Doing so may cause structural failure and void the warranty.

Do not operate an attachment without the case-drain line properly installed if the attachment uses a rotation system that requires a case drain. Doing so will cause immediate failure of the rotate motor and gearbox.

Do not work on the attachment before ensuring it will not move. Completely lower the boom to the ground or a rest position and relieve hydraulic pressure.

Never operate poorly maintained equipment. When maintenance is required, repair or replace parts immediately.

Do not operate under unsafe conditions. If an unsafe condition arises during operation, immediately shut down the equipment and report the situation to the proper authority.

MAINTENANCE SAFETY

Do not work on any hydraulic lines or components while they are pressurized. Escaping hydraulic fluid can penetrate the skin, causing serious injury or death. Relieve pressure before performing maintenance. Keep hands and body parts away from pin holes and nozzles, which eject fluids under high pressure. Use a piece of cardboard to search for leaks.



If fluid is injected into the skin, seek medical assistance immediately from a doctor familiar with this type of injury.

NOTICE

See "Use Care with Hydraulic Fluid Pressure", page 13

Hydraulic oil becomes hot during operation. Do not let hydraulic oil or components contact skin, as it could cause severe burns. Allow hydraulic components to cool before working on them. Use protective clothing and safety equipment.



Remove paint before welding or heating. Hazardous fumes/dust can be generated when paint is heated by welding, soldering or using a torch. Do all work outside or in a well ventilated area and dispose of paint and solvent properly.

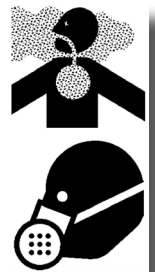

When sanding or grinding paint, avoid breathing the dust. Wear an approved respirator. If you use solvent or paint stripper, remove stripper with soap and water before welding. Remove solvent or paint stripper containers and other flammable materials from area. Allow fumes to disperse at least 15 minutes before welding or heating.

Avoid fire hazards. Keep the area clean. Remove all flammable materials from the area during any welding or heating process. Have a fire extinguisher nearby and know how to use it.



Never substitute pins or bolts. Use factory supplied pins. Replace all bolts with the same size and grade. Failure to do so may cause serious injury or death.

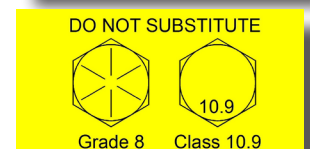

MAINTENANCE SCHEDULE

Performing scheduled maintenance will promote safe, reliable operation of your attachment. Use maintenance procedures described in this manual. If you are not able to safely and competently perform these procedures, have a Genesis dealer perform them.

NOTICE

Extreme operating conditions may require shortened maintenance intervals.

Eight-Hour Checklist

Inspect:

- Bolts - check for loose bolts, replace if damaged
- Fittings and hoses for damage or leaks
- Cylinder for damage or leaks
- Hydraulic swivel for damage or leaks
- Entire attachment for cracks (visual check)

Grease:

- Slewing ring and drive gear

Long-term Maintenance

- Check all bolts for loose washers, including slewing ring bolts, after the initial 80 hours of operation
- Reseal cylinder every 2000 hours

BOLT TORQUE SPECS

**Bolt torque specs and thread treatment procedures can be found in the
Genesis Fastener Manual.
genesisattachments.com/manuals**

LUBRICATION POINTS



Shut off excavator or skid steer and disable hydraulics per OEM instructions before greasing.

For normal conditions above 32°F (0°C), use a lithium-based, premium grade 2 extreme-pressure grease. For temperatures below 32°F, use a grade 0 grease.

Do not use grease containing Molybdenum (Moly).

Genesis GLG-2® anti-wear, extreme-pressure lithium grease, PN 6302601, is recommended for all temperature conditions.

Grease all fittings every eight hours of operation. Grease until extrusion is visible. Grease at the end of the shift when the attachment is warm.

After greasing the rotation bearing, rotate the attachment through two full rotations.

Grease locations:

1. Front cylinder pin
2. Rear cylinder pin
3. Pivot group
4. Remote grease fitting for rotation bearing
5. Gear teeth inside bearing shroud



JAW SET CHANGE-OVER

Jaw Removal

It is safer, easier and quicker to change the jaw sets with two people; one person to remove the attaching pins and the other to operate the machine.

Position the Versi Pro with the lower side of the stick toward the ground. Set the tool firmly onto flat, level ground.

Fully close the attachment jaw. Remove the pin head retaining bolts from both the front cylinder pin and the jaw connection pin. (Fig. 1)

Remove the front cylinder pin. Slowly retract the cylinder rod (jaw open function). If the upper jaw moves, stop and pry the cylinder clevis away from the upper jaw.

Fig. 1

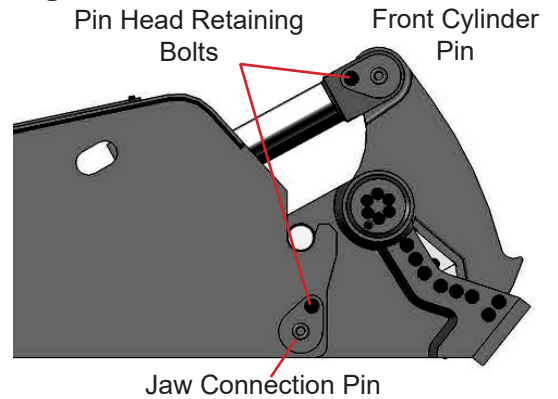

WARNING

Close the jaws before rotating the Versi Pro back to the vertical position. Failure to do so will allow the jaw to slam shut which may cause serious injury or damage to the machine.

Remove the jaw connection pin. This can also be done by raising the attachment and carefully rotating the stick so the jaw connection pin head is facing downward, then tapping the pin out.

With the pins removed and the attachment stick returned to a position with the lower side of the stick facing the ground, raise the stick up and tilt the jaw toward the ground until the lower jaw attachment pins clear the stick body attachment hooks. The stick will be tilted about 30° or more when the jaws disconnect from the stick. (Fig. 2)

Jaw Installation

The jaw set to be installed should be placed on firm level ground with the cylinder connection facing upward.

Tilt the shear stick into a 30° position to connect the stick body attachment hooks onto the lower jaw attachment pins. Once they are connected, tilt the shear stick back into a horizontal position making sure the attaching pins are firmly inside the attaching hooks. (Fig. 2)

Install the jaw connection pin and its retaining bolt. If the jaw had been rotated to install the pin from the top, rotate it back so the lower side of the stick is again facing the ground. (Fig. 1)

Extend the cylinder rod (jaw close function) until the cylinder connection aligns itself to the jaw connection. Install the front cylinder pin and its retaining bolt. Slowly open and close the jaw, checking for any interference.

Fig. 2

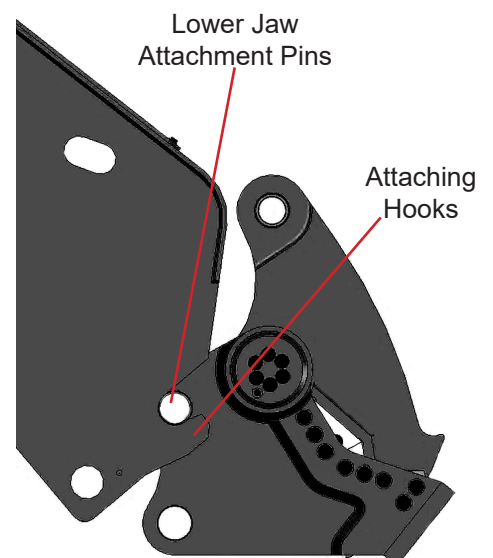

JAW SET MAINTENANCE

Pivot Group Adjustment Rev A

Maintain proper pivot group adjustment to optimize cutting performance and maximize the life of the jaw set. Use the following procedure, along with the accompanying drawing, for initial set-up and to make adjustments as the bearings wear.

1. Loosely assemble pivot group without end caps.
2. Set blade gap by pushing upper jaw blades against lower jaw blades with a 0.010" shim between them.
3. Ensure sleeve 1 is pressed tightly against upper jaw flange bearing 1. Measure the dimension D1 and install shims to eliminate this gap. Fasten end cap 1 to the shaft on this side.
4. Measure the dimension D2 and install appropriate shims.
5. Ensure end cap 1 is pressed tightly against the lower jaw and measure dimension D3. Subtract D3 from 0.255" to determine the shim thickness required under the end cap. Use a 3/8" dowel pin or a light film of grease to hold shims in place.
6. Tighten end cap 2. Verify a 0.005" clearance in the pivot group with a feeler gauge between the sleeve and the flange bearing on either side of the upper jaw.
7. Grease pivot group as described in this manual.

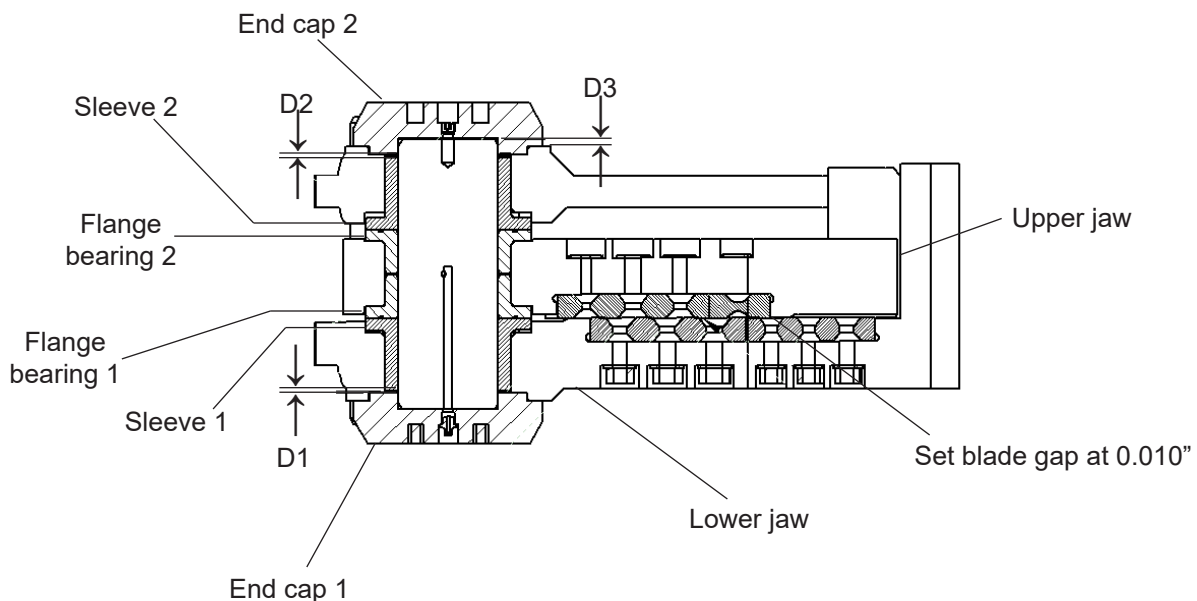

SHEAR JAW SET MAINTENANCE

Daily Maintenance Checks

Perform the following daily maintenance checks to keep the equipment in good operating condition.

- Ensure proper pivot group adjustment.
- Check blades, guide block and piercing tip for excess wear. Rotate or replace as needed.
- Inspect jaw for wear, including the chin where the piercing tip meets the lower jaw. Perform build-up and hard-surfacing as needed.

Piercing Tip

Proper maintenance of the piercing tip boosts productivity and prevents material jams. Inspect the piercing tip daily for wear and perform maintenance every 20-40 hours, depending on the application.

Slowly cycle the shear until the piercing tip is flush with the top edge of the chin.

Check the gap with a tape measure. Acceptable gap is 1/4" – 3/8" (6 - 9.5 mm).

Check the condition of the piercing tip with a straight edge or square. Check the profile along the blades.

If the piercing tip is only slightly worn, it can be built up following the build-up and hard-surfacing procedure in this manual. When the tip is severely worn, it must be replaced.

Piercing Tip Replacement

Important: Remove the upper secondary blade and upper wear plate during this procedure to prevent damage.

Preheat the tip area to 350° F (177° C), six to eight inches around the tip. Maintain this temperature throughout the procedure. Do not exceed 400° F interpass temperature.

Air arc to remove the piercing tip. Clean the pocket and chamfer the perimeter at 1/2" x 45° angles.

Position and tack the new piercing tip in place, square with the blades and new wear plate.

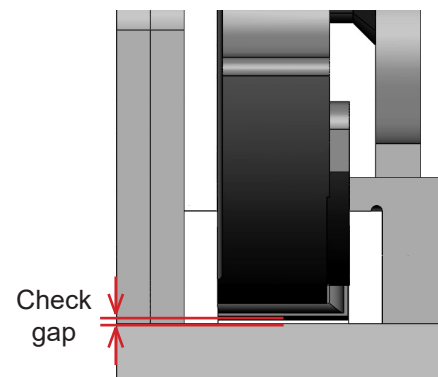
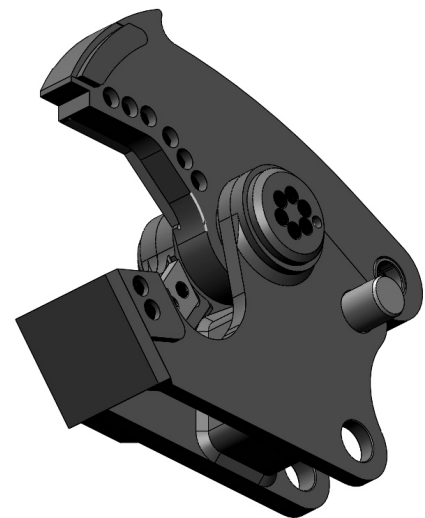
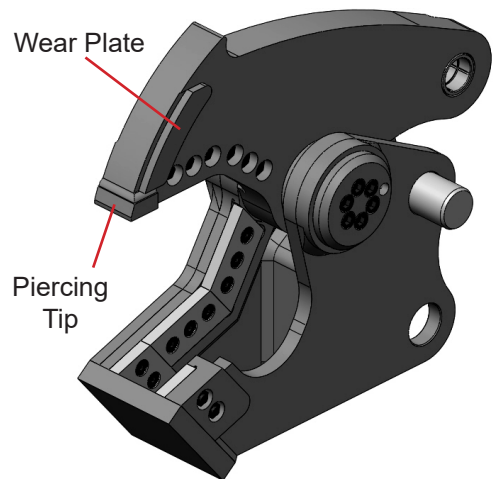

SHEAR JAW SET MAINTENANCE

Weld with AWS E7018 electrode. Begin with the sides, filling in the chamfered area with single passes, alternating sides and peening each pass. Weld the back and front following the same method.

When welding is complete, grind the welds flush on each side.

Cycle the jaw slowly to check for interference.

Cover with heat blanket and allow to cool slowly.

DO NOT put unit into operation until cool.

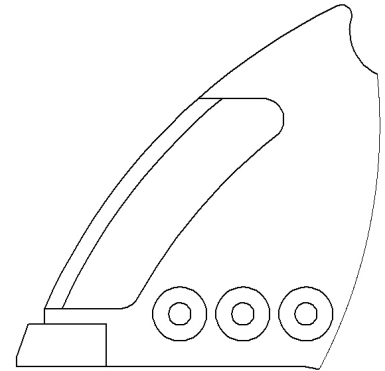

Wear Plate Replacement

Important: Remove the upper secondary blade during this procedure to prevent interpass temperature.

Position and tack the new wear plate in place.

Weld with AWS E7018 electrode. Begin with the area between the wear plate and piercing tip.

Fill in the area with single passes, peening each pass. Weld the back and front following the same method.

When welding is complete, grind the welds flush with the wear plate and piercing tip.

Cycle the jaw slowly to check for interference.

Cover with heat blanket and allow to cool slowly.

DO NOT put unit into operation until cool.

SHEAR JAW SET MAINTENANCE

Guide Blades

After performing piercing tip maintenance, check guide blade tolerances. When necessary, shim the guide blade to keep the gap within 0.005" - 0.010".

Rotate the guide blades when worn to a 1/8" (3 mm) radius. Replace the guide blade when more than 0.075" (2 mm) of shims are required to keep the blade gap within the tolerances.

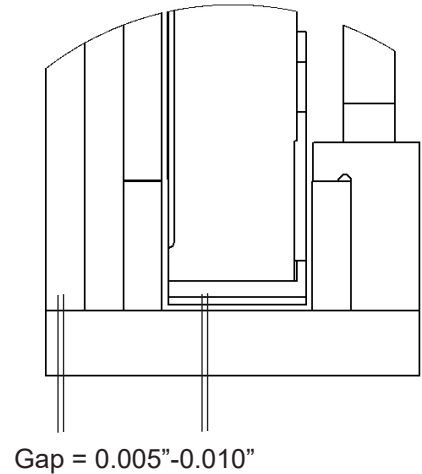

Guide Blade Shimming

Slowly close the jaw so the upper piercing tip begins to bypass the guide blades. Stop the jaw and check the gap between the guide blades and piercing tip. Cycle the jaws slowly, stopping at several points along the piercing tip to check the gap each time.

Shim the guide blades as needed to keep the gap within a 0.005" - 0.010" tolerance.

To install shims, loosen blade bolts and slide shims between the guide blade and guide blade seat. Re-torque bolts and recheck the gap.

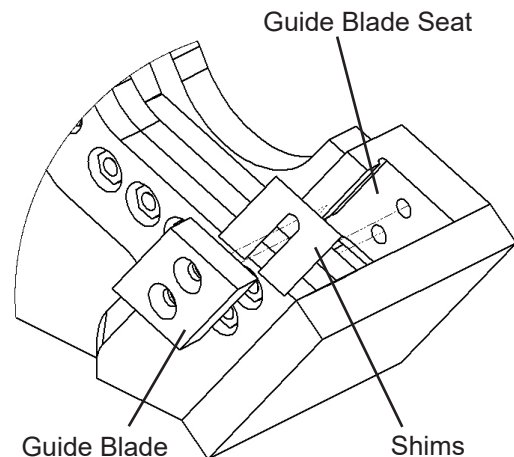
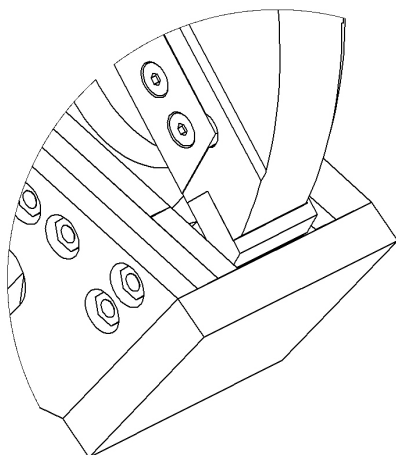

SHEAR JAW SET MAINTENANCE

Guide Blade Rotation

Remove the blade bolts, guide blade and shims. Rotate the blade end-for-end or side-to-side; reinstall and torque bolts. Check gap; shim if required.

If the guide blade faces are excessively worn, the blades cannot be rotated. Excessively worn blades will have uneven surfaces that, when placed upon guide blade seat surfaces, will not be supported and will break, resulting in blade seat damage.

Guide Blade Replacement

Remove guide blade and shims. Install new guide blade with no shims. Check blade gap and shim as needed.

Cutting Blades

Proper maintenance of the cutting blades is required for optimal performance. Blade rotation extends blade life. Dull blades make the carrier hydraulic system work harder and may cause structural damage to the Versi Pro.

Rotate blades to use all four cutting edges. Always use Genesis-approved blades. Blades that do not meet Genesis specifications can cause major problems and using them may void the warranty.

Before performing any blade maintenance, read, fully understand and follow these safety rules.

Wear personal safety equipment including gloves, safety glasses, safety boots and proper clothing.

Never strike a blade with a hardened steel tool. The blade may fragment, creating sharp flying objects.

Cutting Blade Removal

Loosen the bolts enough to loosen the blades, one blade at a time.

Carefully remove bolts and blades.

Blade Bolts

Visually check for loose or broken bolts daily. Re-torque loose bolts to the specifications listed in the Genesis Fastener Manual. **Replace broken bolts immediately.**

SHEAR JAW SET MAINTENANCE

Cutting Blade Rotation

Inspect blades every eight hours of operation. Re-torque loose bolts and replace broken bolts. Rotate blades when the cutting edges are worn to a 1/8" (3 mm) radius.

Recommended rotation intervals are approximately 20-80 hours, depending on the material being processed. Thin materials may require shorter rotation intervals. Blades must be replaced when all four edges are worn to an 1/8" (3 mm) radius.

The following chart may be copied and used to track blade rotation.

40-80 Hours	Date	Hour Meter	Performed By
Installed			
Rotation 1			
Rotation 2			
Rotation 3			

Cutting Blade Gap Adjustment & Shimming

After each blade rotation, shim the lower blades to keep the gap within 0.005 to 0.010. Do not shim the upper blades. Use only Genesis shim kits.

Slowly close jaws until blades begin to bypass. Stop the jaw and check the gap with a feeler gauge.

Cycle the jaws slowly and continue checking the gap at several points along the entire length of the blades.

If the blade gap exceeds the maximum listed on the table above, shim the lower blades. Blades must be replaced when shims exceed 0.060".

Loosen blade bolts.

Install shims between the blades and blade seat as needed to bring into tolerance.

Torque bolts to spec and recheck the tolerances.

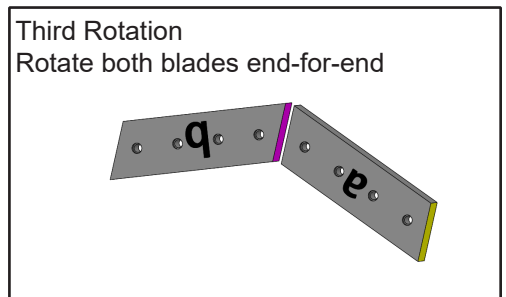
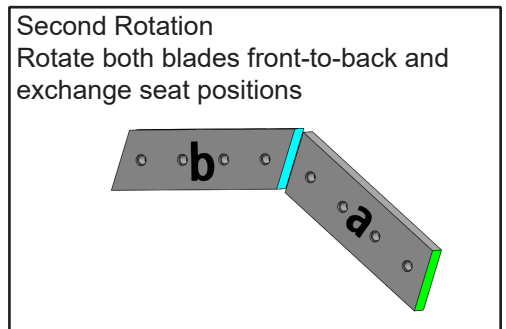
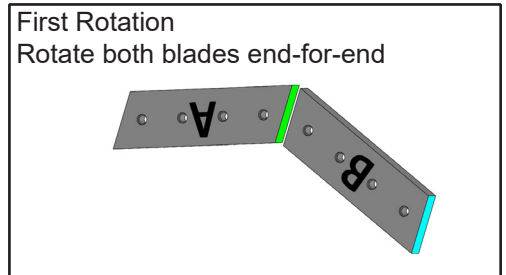
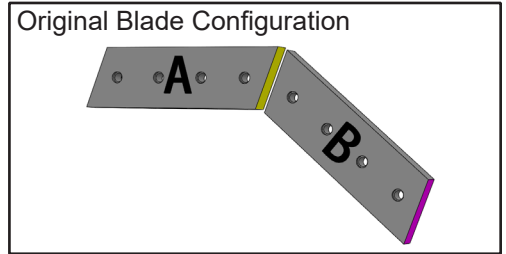

CONCRETE CRACKER JAW SET MAINTENANCE

Replace teeth when points are worn down and can no longer process concrete efficiently. Weld new teeth in place using the following procedure.

If desired, points may also be rebuilt and hard-surfaced when 1/2" has worn away, as shown in the illustration. However, rebuilt points on the teeth will wear down faster than the original teeth.

Tooth Replacement Procedure

Follow all welding safety precautions found in this manual.

Preheat the jaws surrounding the teeth to 350° F (177° C), being cautious to stay away from the pivot group. Maintain this temperature throughout the procedure. Do not exceed 400° F (204° C) interpass temperature.

Air arc to remove worn teeth using a template available from the Genesis Parts Department. Grind jaw surfaces smooth to accept new teeth.

Position and tack the new teeth in place as shown.

Weld with AWS E7018 electrode or equivalent. Begin with the sides, filling in the chamfered area with single passes, alternating sides and peening each pass. Weld the back and front of each piece following the same method.

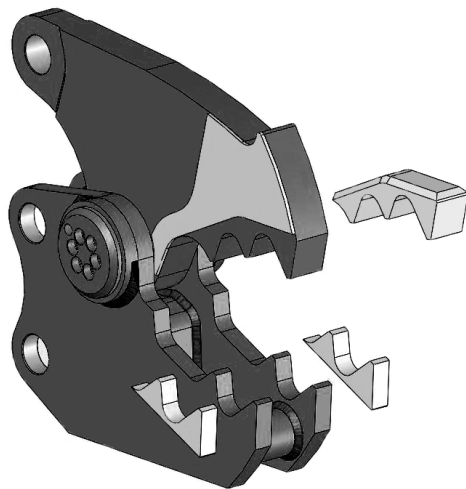
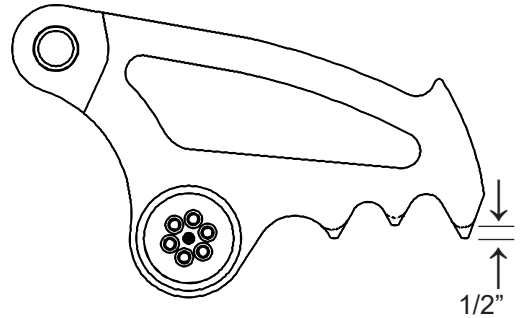

When welding is complete, grind the welds flush on the sides of the upper jaw. Failure to grind these surfaces flat may prevent the teeth from bypassing the lower teeth.

Cycle the jaw slowly to check for interference.

Cover with heat blanket or insulation and allow to cool slowly.

DO NOT put unit into operation until cool, approximately eight hours.

WIRE CUTTER JAW SET MAINTENANCE



CAUTION

The wire cutting jaw set is solely designed to process single or multi-strand wires made of non-ferrous metals such as aluminum or copper.

High strength alloys of these metals **may not** be processed with this jaw set. Single strand wires processed with this jaw set may not be larger than 200 mm (7-7/8 inches) in diameter including the insulation. Furthermore, the wires may not be coated with materials having higher tensile strength or hardness than copper or aluminum. (e.g. steel) Processing of such materials will damage the blades and the entire jaw set.

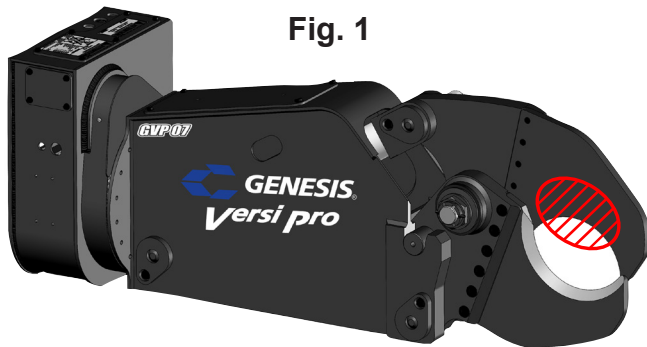

Fig. 1

When cutting multiple wires at once, the circumference of all the wires must be inside the jaw during the entire cutting cycle.

Contact Genesis or your local Genesis Dealer before using the wire cutting jaw set in an application not described above.



WARNING

Always fully extend the cylinder before removing the Front Cylinder Pin (PN 3500352), otherwise the upper jaw may suddenly and unexpectedly close.



CAUTION

When changing jaw sets be sure the jaws are securely positioned even when uncoupled from the stick.



CAUTION

Never activate the rotation function of the shear without having the jaw set properly engaged.



CAUTION

Do not operate the GVP attachment until the jaw set is properly installed and the front cylinder pin is inserted and secured.

WIRE CUTTER JAW SET MAINTENANCE

Wire Cutter Jaw Removal

To properly cut the material for which it's designed, the wire cutter is very narrow, so a special Wire Cutter Jaw Stand has been developed to facilitate the jaw changing process.

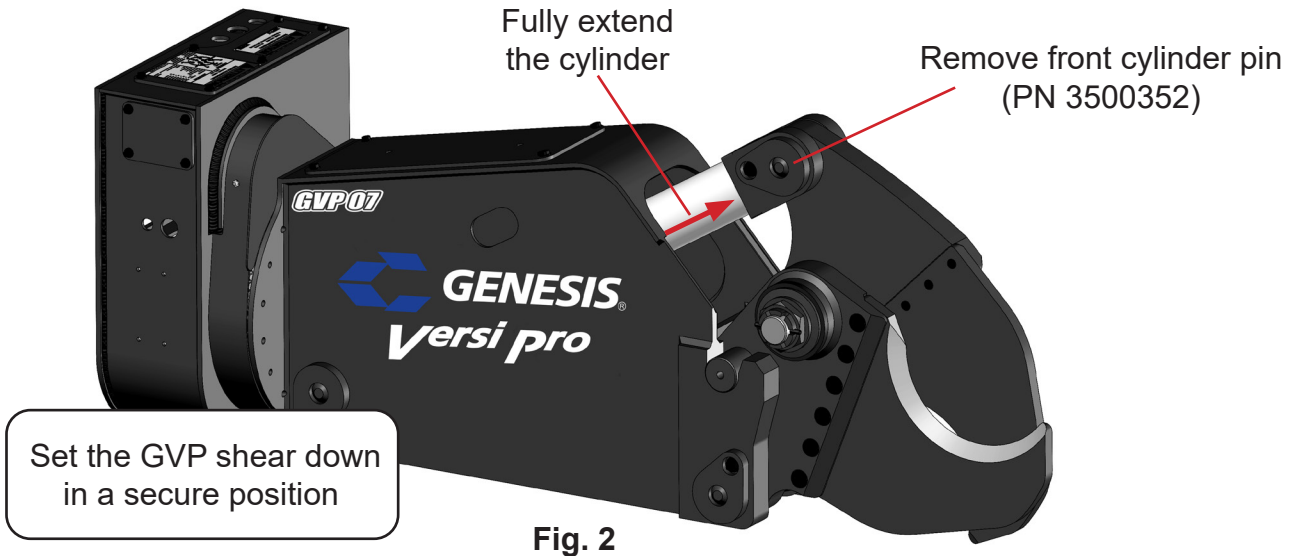
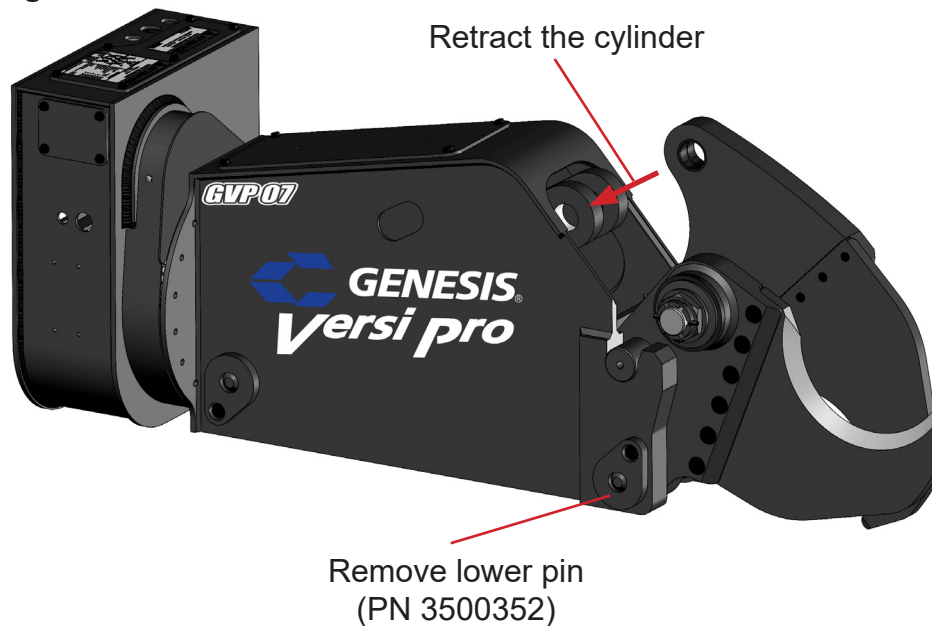
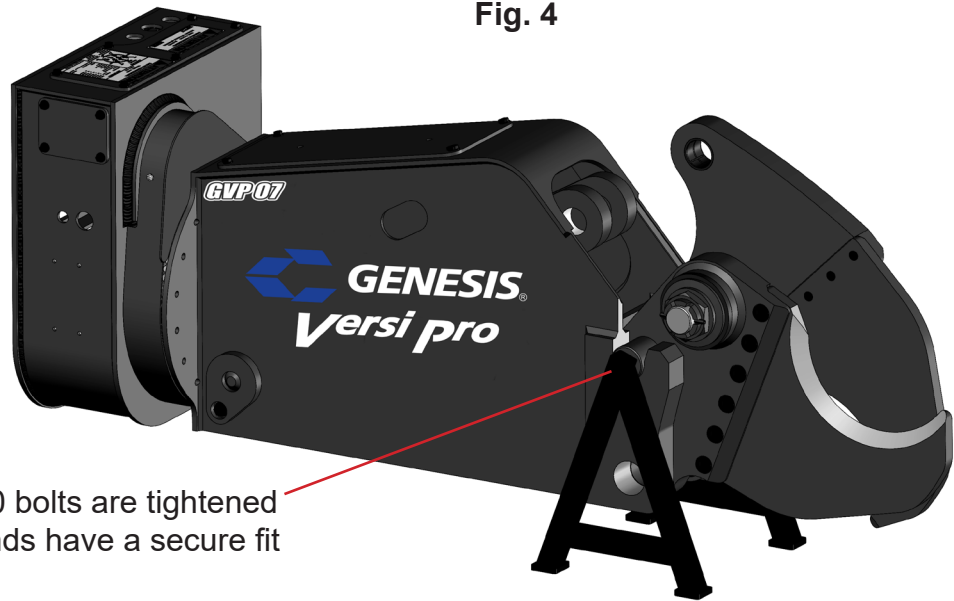

Fig. 3



WIRE CUTTER JAW SET MAINTENANCE

Fig. 4



Make sure the M16 x 2.00 bolts are tightened only to the extent the stands have a secure fit but can still swing freely

Mount the wire cutter jaw stand (PN 3501533) on both sides of the jaw set

Fig. 5

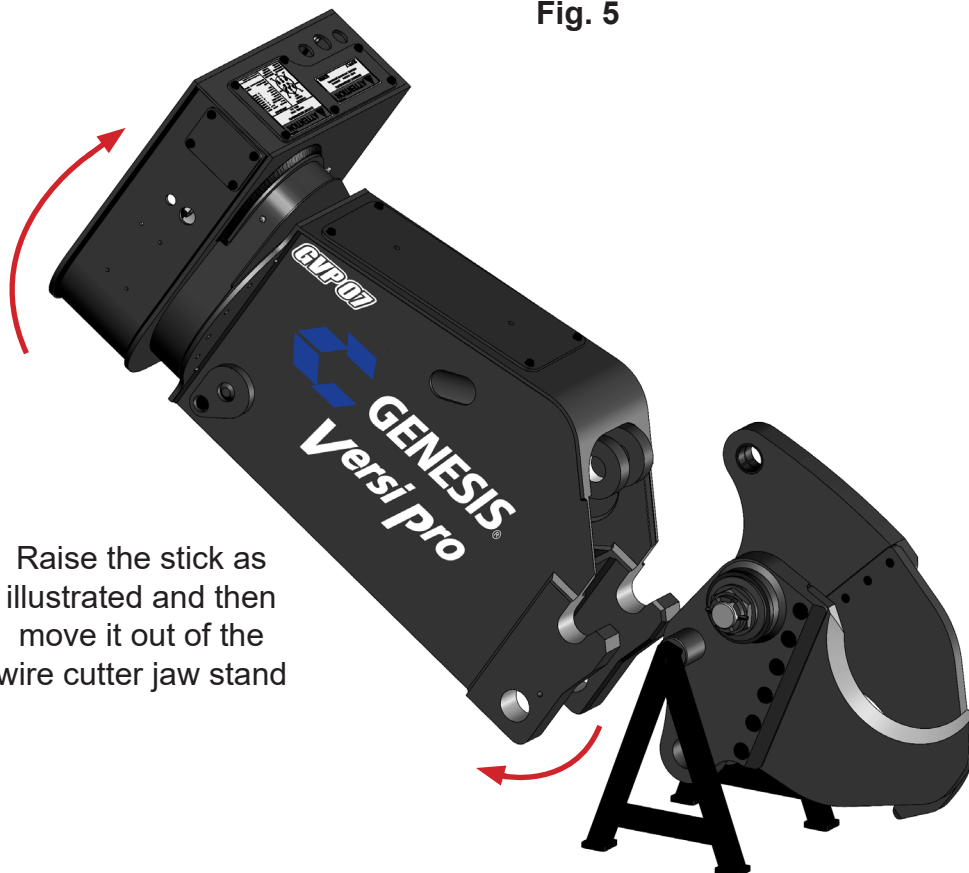

Raise the stick as illustrated and then move it out of the wire cutter jaw stand

WIRE CUTTER JAW SET MAINTENANCE

Wire Cutter Jaw Installation

Fig. 6

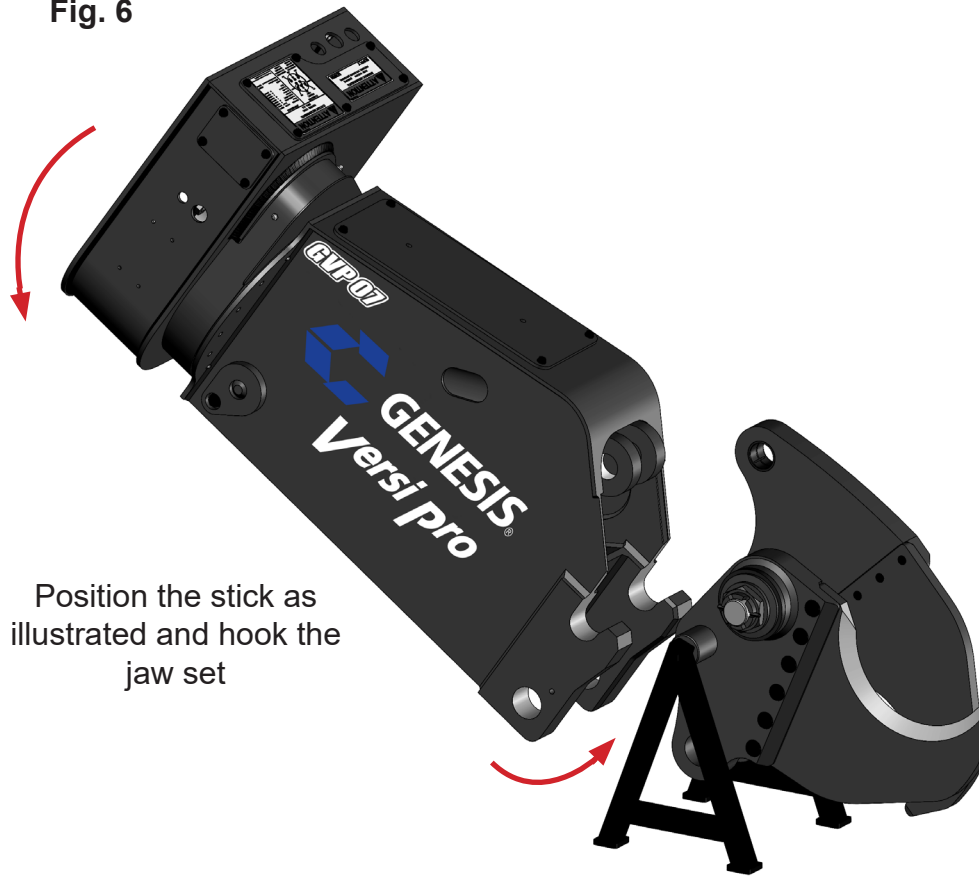

Position the stick as illustrated and hook the jaw set

Fig. 7



Rotate the stick until the stick and lower jaw bores align and install lower pin

Lower pin (PN 3501023)

WIRE CUTTER JAW SET MAINTENANCE

Fig. 8

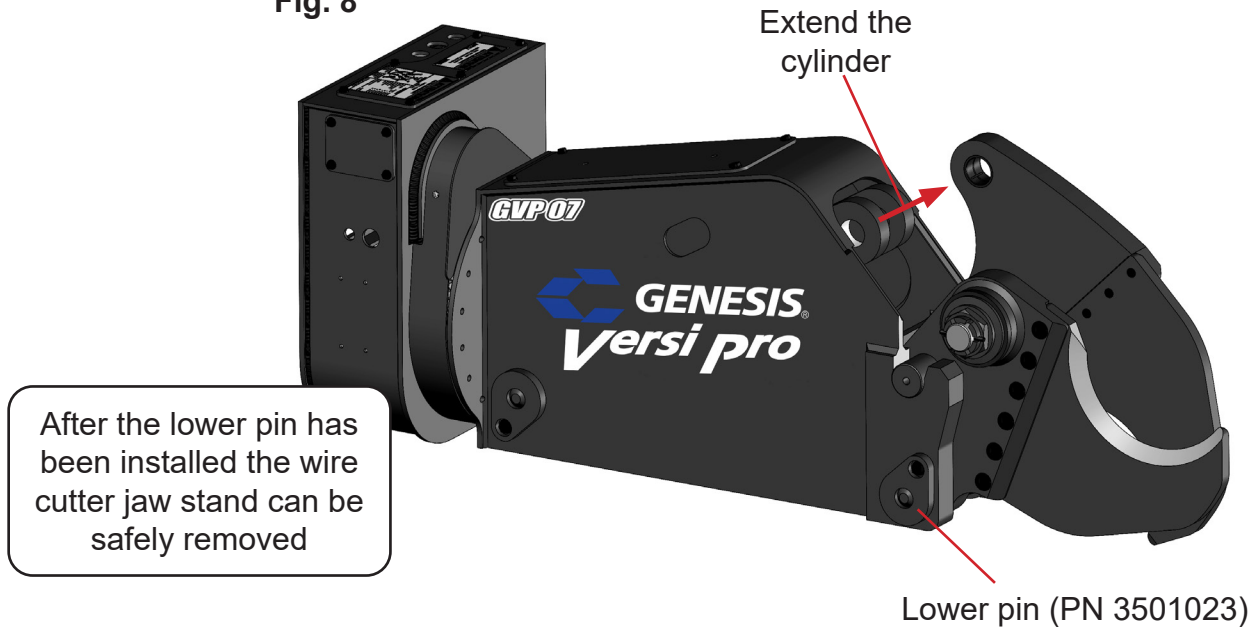

Extend the cylinder until the bores of the cylinder rod end and the upper jaw align and install the cylinder rod end pin.

Fig. 9

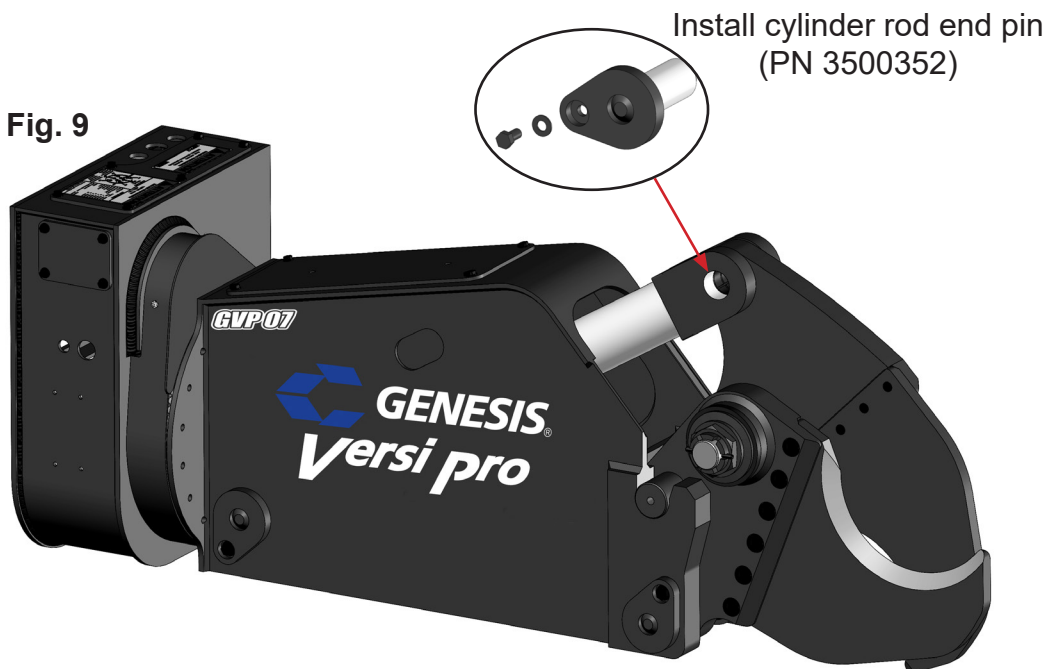

WIRE CUTTER JAW SET MAINTENANCE

Fig. 10

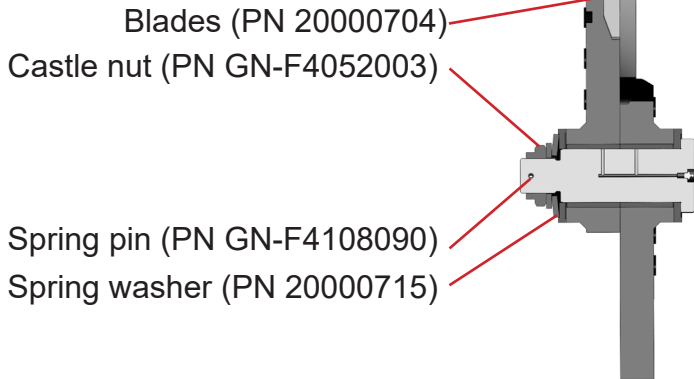

The blade gap as well as the pre-load of the blades are set through the castle nut with spring washer. The spring washer preserves the tension of the blades until they are worn in significantly. As the blades wear in, adjust the castle nut to restore tension.

To add tension to the blades remove spring pin, tighten the castle nut, then replace the spring pin.



CAUTION

The cutting edges can be very sharp, even after use. Always wear suitable protective gear and gloves.

To change the blades, remove the bolts (F0620040) then remove the blades and replace with new or resharpened blades. Re-install the bolts and tighten to 450 Ft/Lbs or 610 Nm. Check blade gap and pre-tension.

To resharpen the blades, they **must be removed** from the shear and reground at a 45 degree angle. While grinding, the temperature of the cutting edges must not exceed 200° C or 392° F to preserve the material properties. The blades must be replaced when they do not overlap in the fully closed position.

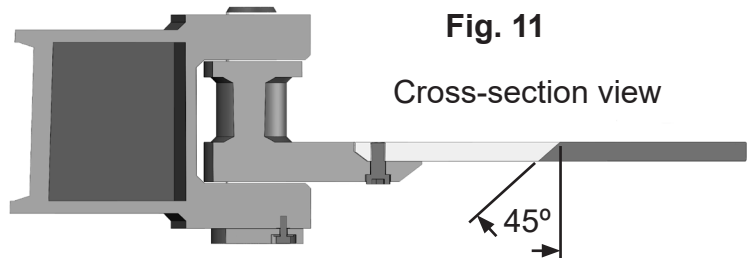
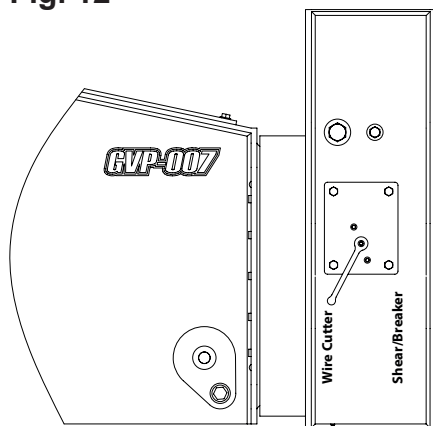

Fig. 12



NOTE:

Before using the wire cutter, the ball valve located on the side of the shear must be set in the wire cutter position.

GRAPPLE JAW SET MAINTENANCE

Check grapple tine tips for wear and replace as needed, following the procedure below. Do not allow tips to wear down to the parent material.

Build-up and hard-surfacing of grapple jaws is optional to prevent excessive wear. Depending on the application, it may or may not be necessary. Use your discretion to determine whether it is warranted by the severity of the application.

Tip Replacement Procedure

Follow all welding safety precautions found in this manual.

Preheat the area to 350° F (177° C), six to eight inches around the tip. Maintain this temperature throughout the procedure. Do not exceed 400° F (204° C) interpass temperature.

Air arc to remove the tip. Clean the pocket and chamfer the perimeter at 5/8" x 45° angles.

Position and tack the new tip in place.

Weld with AWS E7018 electrode. Begin with the sides, filling in the chamfered area with single passes, alternating sides and peening each pass. Weld the back and front following the same method.

When welding is complete, grind the welds flush on each side.

Cover with heat blanket or insulation and allow to cool slowly.

DO NOT put unit into operation until cool, approximately eight hours.

GENERAL WELDING GUIDELINES

Build-up and hard-surfacing are welding procedures that protect the parent material of the jaws and keep the blades in good adjustment. Build-up is the welding procedure that restores the jaws to their original shape. Building up the jaws helps protect the blades and increases the life of the attachment. Hard-surfacing is the welding material added over the parent material (or build-up material) to create a wear-resistant surface.

Welding should not be performed until the jaws are work-hardened. Work-hardening can take up to 80 hours. However, jaws must not wear lower than the height of a new blade. If either jaw wears down lower than blade height, immediately stop operating the attachment and perform build-up and hard-surfacing as described in the following pages of this manual.

Welding Ground Clamp

Disconnect all battery ground cables or shut off master battery switch, if equipped. Failure to do so may cause carrier electrical problems, including permanent damage to onboard computer systems.

Connect ground clamp as close as possible to the area being welded without allowing current to pass through the pivot group, cylinder pin, cylinder, swivel, motor, gearbox or slewing ring.

If you are welding on the lower jaw, connect weld clamp to the lower. If you are welding on the upper jaw, connect to the upper but not to the cylinder clevis. If needed, weld a piece of steel to the area for the grounding clamp and cut the piece off when welding is completed.

Welding Rules

Before you begin:

- Remove adjacent blades, as preheating and welding may cause blade damage.
- Wearing an approved respirator, grind the area to clean it, removing all existing hard-surfacing.
- Preheat area to 350° F (177° C). Maintain this temperature throughout the procedure. Do not exceed 450° F (232° C) interpass temperature.

During welding:

- Always grind and weld with the grain of the material.
- Peen each weld pass to relieve stress and harden the welds.
- Do not undercut the ends of the welds.
- Do not start or stop welds directly above a bolt hole or in the apex of the jaw.

After welding maintenance is complete:

- Cover the area with a heat blanket and allow it to cool slowly, approximately eight hours.
- Do not put the attachment into operation until the welds have been allowed to cool.

BUILD-UP

Procedure:

Follow the General Welding Guidelines and Rules.

Determine the area to build up, using a straight-edge or square. Jaws must not wear lower than the height of a new blade. Use a new blade to help determine build-up height for the jaw.

Build up the jaw to slightly higher than the original parent material profile with E7018. Apply single passes in each line with the grain of the steel, peening after each pass.

Protection strips, or raised areas under or around blade seats, must be built up and maintained during build-up procedure using E7018 or equivalent.

These areas should be maintained between blade height and 0.010" lower than blade height. These areas protect the bottom unused edges of the blades as well as reduce the chance for material to catch on the bottom of the blade during jaw open functions, which causes blades to move in their seats.

Denting, deformation or build-up higher than blades in these areas may cause upper jaw deflection, excessive blade gaps, wear to blade faces and undue stress to upper and lower jaws.

After build-up is complete, grind material to be flush with a new blade.

Note: Closely monitor areas above guide blade bolt countersinks and below front two upper blade bolt countersinks. These are high-wear areas. If allowed to wear too far, parent material starts to fold into the countersinks, and it becomes time-consuming to clean out this area when access is needed for blade rotation and replacement.

HARD-SURFACING

Do not apply hard-surfacing directly to the parent material as this could cause toe cracking, and the hard-surfacing will break away.

Procedure:

Follow the General Welding Guidelines and Rules.

Apply a single pass stringer bead pattern, with the grain, using E7018 electrode. Peen each pass.

Do not apply a stringer directly on the edge. Start the first pass 1/4" from the edge.

Stagger the ends of the stringer welds so they do not end in a straight line.

Cap each stringer bead with one pass of GenWire or GenRod to hard-surface. Do not apply more than two layers of hard-surfacing. Peen each pass.

Grind the ends of all stringer welds with the grain to taper 1" to 1-1/2" (25 - 38 mm) to the parent material.

See the following page for hard-surfacing illustrations and instructions specific to each area of the jaws.

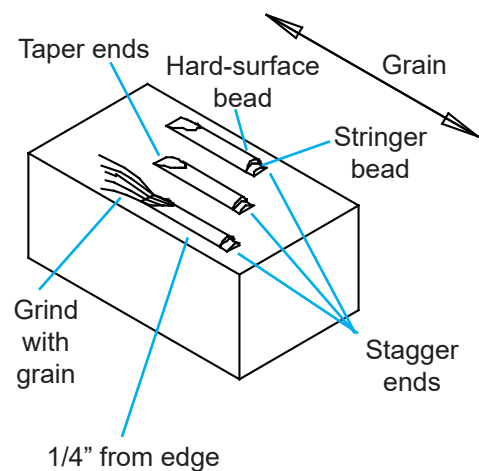

WELDING MAINTENANCE

Hard-Surfacing Patterns

Where parallel lines are shown, apply single passes approximately 3/4" apart. Where crosshatch is shown, apply stringer beads at 45° angles to form 3/4" squares.

Hard-surfacing patterns are indicated by red lines in the drawings.

Do not crosshatch the curved areas of the jaws near the pivot. Use only straight stringers on these areas.

Follow hard-surfacing instructions on the previous page.

GVP 07 Shear Jaw Set

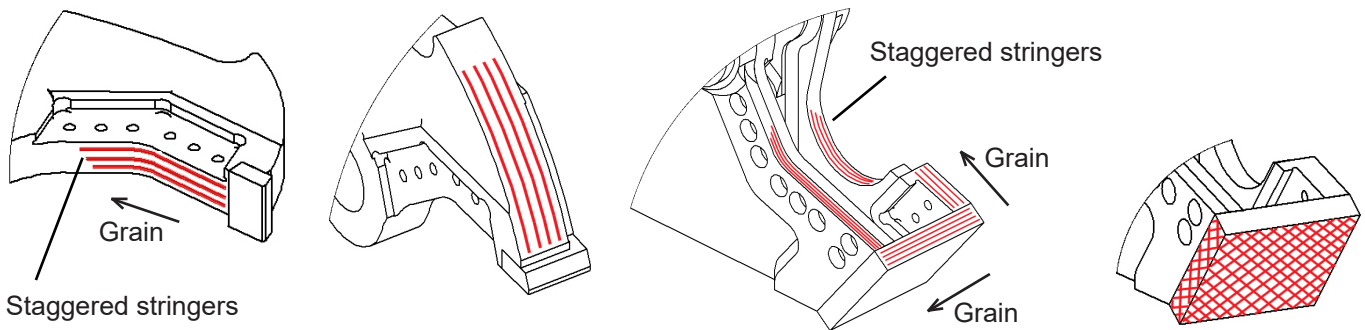

GVP 07 Cracker Jaw Set

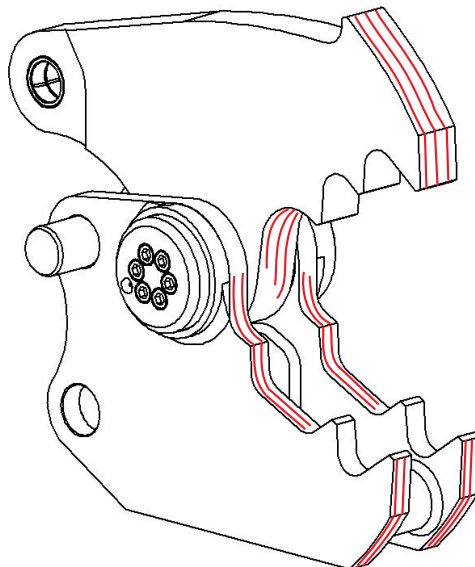

HYDRAULIC / ROTATION MAINTENANCE

Mounting Bolts

Visually check slewing ring (rotation bearing) bolts every eight hours of operation and replace every 2000 hours. Do not reuse or re-torque these bolts. Immediately replace a loose or broken bolt, and replace the bolts on either side of it.

Bolt Torque

The bolts that secure the slewing ring are critical to safe operation of the attachment. Improper bolt torques may cause the bolts to fail and allow the attachment to break free. This may result in serious personal injury and damage to equipment. Improper torques will also cause uneven wear on the slewing ring. See the Genesis Fastener Manual for proper bolt torque specifications.

Grease Daily

Rotating components must be greased daily. The rotation bearing features a remote grease fitting at the top of the quick-attach plate. The gear teeth should also be greased and can be accessed by removing the bearing shroud.

Stand Clear

Stand clear when the Versi Pro is being rotated. Always stay in clear view of the operator.

Rotate After Greasing

Grease each slewing ring grease fitting with several strokes and rotate the attachment two full rotations after greasing each fitting.

Grease Temperatures

For normal conditions above 32°F (0°C), use a lithium-based, premium grade 2 extreme-pressure grease. For temperatures below 32°F, use a grade 0 grease. **Do not use grease containing Molybdenum (Moly)**. Genesis GLG-2® anti-wear, extreme-pressure lithium grease, PN 6302601, is recommended for all temperature conditions.

Hydraulic Requirements

Jaw Circuit	Hydraulic Pressure	Rotate Circuit	Hydraulic Pressure
Flow	15-25 gpm (57-95 lpm)	Flow	1-3 gpm (3-11 lpm)
Pressure	2500-3650 psi (172-252 bar)	Pressure	1500-1700 psi (103-117 bar)



DANGER

Operating above recommended flow and/or pressure may cause damage and/or create a dangerous situation.

Electrical Requirements

- 12 VDC keyed power @ 10 amps
- OEM quick-disconnect on boom for joystick button signals
- 2 rocker-type switches in joystick handles for open/close, rotate
- 1 momentary toggle switch for regen override (optional)

TROUBLE-SHOOTING GUIDE

Jaw Set

Symptom	Possible Cause	Possible Solution
Lacks power	Circuit not getting full pressure from excavator	Check hydraulic pressure at port block
	Shear cylinder or swivel bypass	Check for bypass and replace seals if needed
	GenFlow valve has faulty cartridge or seal bypass	Contact Genesis Service Department Check valve seals, replace as needed
Poor cutting	Material size is beyond shear appetite range	Consult the factory
	Worn blades	Refer to Jaw and Blade Maintenance in this manual
	Excess blade gap	
Poor piercing	Piercing tip or chin is worn	Refer to Jaw and Blade Maintenance in this manual
Material jamming	Excess blade gap	Refer to Jaw and Blade Maintenance in this manual
	Worn blades	
	Worn piercing tip, chin or guide block	
Slow jaw cycle in open direction	Excess back pressure on return side of cylinder	Check excavator main control valve or hydraulic line size
Jaw drifts closed or can be pushed closed	Excavator control valve	Check excavator main control valve
	Processor cylinder or swivel bypass	Check for bypass and replace seals if needed
	GenFlow valve seal bypass	Replace seal as necessary

TROUBLE-SHOOTING GUIDE

Rotator

Symptom	Possible Cause	Possible Solution
Does not rotate	Blown fuse	Replace fuse
	Electrical problem	Test for proper voltage at plugs on directional valve while depressing foot switch
	Incorrect pressure settings	Set pressures
	Faulty components	Contact Genesis to replace valve
Does not rotate in one direction	No electrical power to one side	Test for 12V at plugs on directional valve while operating controller
	Faulty directional control valve	Check if directional control valve shifts both ways while actuating foot switch in both directions
	Faulty cartridge	Contact Genesis to replace valve
Rotator chatters	Electrical short	Check on VOM meter
	Power to both rotation solenoids at the same time	Test for 12V at plugs on directional valve while operating controller
Rotates too fast or too slow	Flow control out of adjustment	Set flow control

WARRANTY

Claim Procedure

Notify the Genesis Service Department of the potential warranty claim prior to making the repair. Digital pictures are very helpful for diagnosing problems and recommending repairs.

Contact the Genesis Service Department before making alterations, changes or repairs to any component that is going to be considered for warranty. Not doing so will void all Genesis warranty consideration.

The Genesis Service Department will issue an authorization number to track the repair costs, outgoing parts, and/or defective parts returning to the factory.

Replacement parts must be ordered using a purchase order number. Shipping is standard ground. Overnight shipping is available by request, and Genesis will not cover the shipping charge.

When the repair is complete, submit an invoice to the Genesis Service Department within 30 days. Include itemized internal labor reporting, parts lists and invoices for outside contractors. Reference the authorization number on all invoices.

When returning parts for warranty consideration, include a copy of any related Genesis paperwork along with any other necessary documentation to ensure proper processing and credit. The Genesis Service Department will provide the necessary forms.

Your account will be credited when the warranty claim is accepted.

Blade Warranty

Standard warranty on blades will only be considered on the first edge, and wear on the edge must be 1/8" radius or less. Genesis does not warranty cutting blades that are cracked or broken from top to bottom (perpendicular to the long edge of the blade). Genesis also does not cover fasteners, the labor to replace wear components or collateral damage, such as blade seats, from broken blades, the piercing blade tang or adjustment plates.

Please direct any questions to the Genesis Service Department: 715-395-5252

PARTS ORDER POLICY AND PROCEDURE

Parts Orders Should Include

- Purchase order number
- Model and serial number of attachment
- Part number and quantity needed
- Shipping and billing address
- Method of shipment or required delivery date

Placing Orders

Orders may be placed by phone or e-mail. To e-mail an order, use the form on the following page or your purchase order form. Contact information is located at the front of this manual.

Part Numbers

Part numbers are listed in a separate Parts Manual or, if included, the Parts section of this manual. Contact the Genesis Parts Department with questions regarding part numbers, availability and pricing.

Shipping

All orders will be shipped best way surface unless an alternate shipping method is requested. Shipping charges are not included in the purchase price of parts.

Invoices

All invoices are due upon receipt. Any accounts with invoices open beyond 60 days are subject to review and may be placed on C.O.D. status without further notice.

Returns

Many unused Genesis parts may be returned with proper documentation. Return shipping is the responsibility of the purchaser. Credit will be issued upon return, less a 25% restocking fee. Documentation is required for credit of returned parts. Contact the Genesis Service Department at 715-395-5252 for an RGA (Return Goods Authorization) number and form. An RGA must accompany every return. Items shipped without an RGA may be returned to sender.

Warranty Returns

All parts returned to Genesis for warranty consideration must be returned with a completed RGA (Return Goods Authorization) provided by the Genesis Service Department. The form needs to be completed in its entirety, including any additional information requested by the Service Department. Return shipping is the responsibility of the sender and will be credited upon claim approval. A determination to accept or deny the claim will be made based upon the information available to Genesis. Warranty on purchased parts other than wear components is 6 months. Genesis does not cover labor costs to replace purchased parts replaced under warranty. There is no warranty period on wear parts or components.



GENESIS®

The Promise of Performance.

CONTACT INFORMATION

Genesis Attachments

1000 Genesis Drive
Superior, WI 54880 USA

Toll Free: 888-SHEAR-IT
(888-743-2748)

Phone: 715.395.5252

E-mail:
info@genesisattachments.com

Europe/Africa/Middle East Genesis GmbH

Teramostrasse 23
87700 Memmingen, Germany

Phone: +49 83 31 9 25 98 0

Fax: +49 83 31 9 25 98 80

genesis-europe.com

E-mail:
info@genesis-europe.com

Asia Pacific Representative Office

24 Upper Serangoon View #12-28
Singapore 534205

Phone: +65 9673 9730

E-mail:
tchoo@genesisattachments.com

Central America & Colombia

Cra 13A #89-38 / Ofi 613
Bogota, Colombia

Phone: +57 1 610 8160 / 795 8747

E-mail:
contact@themsagroup.com

View and download all manuals: genesisattachments.com/manuals
Patents: genesisattachments.com/products/patents

Rev. 11-11-24