

GENESIS®

The Promise of Performance.

Handling Grapple (GHG) Models GHG 75 - GHG 125

SAFETY & OPERATOR'S MANUAL



CONTACT INFORMATION

Genesis Attachments

1000 Genesis Drive
Superior, WI 54880 USA

Toll Free: 888-SHEAR-IT
(888-743-2748)

Phone: 715.395.5252

E-mail:
info@genesisattachments.com

Europe/Africa/Middle East Genesis GmbH

Teramostrasse 23
87700 Memmingen, Germany

Phone: +49 83 31 9 25 98 0
Fax: +49 83 31 9 25 98 80
genesis-europe.com

E-mail:
info@genesis-europe.com

Asia Pacific Representative Office

24 Upper Serangoon View #12-28
Singapore 534205

Phone: +65 9673 9730

E-mail:
tchoo@genesisattachments.com

Central America & Colombia

Cra 13A #89-38 / Ofi 613
Bogota, Colombia

Phone: +57 1 610 8160 / 795 8747

E-mail:
contact@themsagroup.com

View and download all manuals: genesisattachments.com/manuals
Patents: genesisattachments.com/products/patents

PREFACE

To ensure years of safe, dependable service, only trained and authorized persons should operate and service your Genesis attachment. It is the responsibility of the product's owner to ensure the operator is trained in the safe operation of the product and has available this manual for review. It is the responsibility of the operator and maintenance personnel to read, fully understand and follow all operational and safety-related instructions in this manual. The attachment should not be operated until you have read and fully understand these instructions. Always use good safety practices to protect yourself and those around you.

Important

This operator's manual must accompany the attachment at all times and be readily available to the operator.

Manual Replacement

Should this manual become damaged or lost or if additional copies are required, immediately contact any authorized Genesis dealer or the Genesis Service Department at 888-743-2748 or 715-395-5252 for a replacement.

Registration Form

The Warranty Registration Form must be filled out by the dealer or customer and returned to Genesis indicating the date the attachment went into service.

Possible Variations

Genesis cannot anticipate every possible circumstance that might involve a potential hazard as the owner's requirements and equipment may vary. Therefore, the warnings in this publication and on the product may not be all-inclusive, and you must satisfy yourself that the procedure, application, work method or operating technique is safe for you and others before operating.

Public Notice

Genesis reserves the right to make changes and improvements to its products and technical literature at any time without public notice or obligation. Genesis also reserves the right to discontinue manufacturing any product at its discretion at any time.

Warranty

All work or repairs to be considered for warranty reimbursement must be pre-authorized by the Genesis Service Department. Any alterations, modifications or repairs performed before authorization by the Genesis Service Department will render all warranty reimbursement consideration null and void without exception. See page 37 for Warranty Claim Procedures.

Improper operation or improperly performed maintenance may render any warranty null and void.

TABLE OF CONTENTS

CONTACT INFORMATION	2
PREFACE	3
Important	3
Manual Replacement	3
Registration Form	3
Possible Variations	3
Public Notice	3
Warranty	3
SAFETY STATEMENTS	6
OPERATIONAL SAFETY	7
Read Manual Before Operating or Maintaining the Attachment	7
Personal Protection	7
Know Your Equipment	7
Before Operating	7
Check the Equipment	8
Stability	8
Know the Work Area	9
Starting Procedure	9
Place the Load Safely	9
Safely Operate Equipment	10
Transporting the Attachment	11
Equipment Condition	11
Working Overhead	11
Power Lines	11
Use Care with Hydraulic Fluid Pressure	12
Prioritized Oil Flow	13
Emergency Situations	13
Unsafe Conditions	13
Crystalline Silica Dust	13
Prop. 65 Warning for California Residents	13
Process Material Safely	14
Lift the Load Safely	14
Place the Load Safely	14
ATTACHMENT MARKINGS	15
MAINTENANCE SAFETY	16
Pinch Points & Crush Points	16
Performing Maintenance	16
MAINTENANCE SCHEDULE	18
Four-Hour Checklist	18
Eight-Hour Checklist	18
Long-term Maintenance	18
LUBRICATION POINTS	19
BOLT TORQUE SPECS	20
GENERAL WELDING GUIDELINES	21
Welding Ground Clamp	21
Welding Rules	21

TABLE OF CONTENTS

BUILD-UP AND HARD-SURFACING	22
Hard-Surfacing Patterns.....	22
HARD-SURFACING	23
HYDRAULIC/ROTATION MAINTENANCE	24
Hydraulic Requirements.....	24
Rotation Valve Input.....	24
Rotation Valve Settings.....	24
SLEWING RING MAINTENANCE	25
ROTATION CIRCUIT	26
Rotation with Motion Control Valve.....	26
BLADE MAINTENANCE	27
Blade Rotation.....	27
GRAPPLE INSTALLATION	28
Installation Procedure.....	28
ROTATOR INSTALLATION	29
Rotation Circuit - Gear Pump Type.....	30
Rotation Circuit - Auxiliary Valve on Machine.....	31
GENERAL OPERATION INSTRUCTIONS	32
Efficient and Productive Operation.....	32
HYDRAULIC START-UP	33
Start-up Procedure.....	33
HYDRAULIC / ROTATION MAINTENANCE	34
Mounting Bolts.....	34
Bolt Torque.....	34
Grease Slewing Ring.....	34
Rotate After Greasing.....	34
Grease Points.....	34
Grease Temperatures.....	34
TROUBLE-SHOOTING GUIDE	35
WARRANTY	37
Claim Procedure.....	37
PARTS ORDER POLICY AND PROCEDURE	38
Parts Orders Should Include.....	38
Placing Orders.....	38
Part Numbers.....	38
Shipping.....	38
Invoices.....	38
Returns.....	38
Warranty Returns.....	38
PARTS ORDER FORM	39
CONTACT INFORMATION	40

NOTICE

For bolt torque specs, see the Genesis Fastener Manual.
genesisattachments.com/manuals

SAFETY STATEMENTS



This symbol by itself or used with a safety signal word throughout this manual is used to call attention to instructions involving your personal safety or the safety of others. Failure to follow these instructions can result in injury or death.



This statement is used where serious injury or death will result if the instructions are not followed properly.



This statement is used where serious injury or death could result if the instructions are not followed properly.



This statement is used where minor or moderate injury could result if the instructions are not followed properly.

NOTICE

This statement is used where property damage could result if the instructions are not followed properly.

OPERATIONAL SAFETY

Read Manual Before Operating or Maintaining the Attachment



Read this manual before attempting to operate the attachment. This operator's manual should be regarded as part of the attachment. For proper installation, operation and maintenance of the attachment, operators and maintenance personnel must read this manual.



WARNING

Serious injury or death could result if appropriate protective clothing and safety devices are not used.

Personal Protection

Use protective clothing and safety devices appropriate for the working conditions. These may include but are not limited to:

- ✓ Hard hat
- ✓ Safety glasses, goggles or face shield
- ✓ Hearing protection
- ✓ Safety shoes
- ✓ Heavy gloves
- ✓ Reflective clothing
- ✓ Respirator or filter mask



Safety matters

Know Your Equipment



Know your attachment's capabilities, dimensions and functions before operating. Inspect your attachment before operating and never operate an attachment that is not in proper working order. Remove and replace any damaged or worn parts.

Before Operating

- ✓ Warn all others in the area that you are about to start operation.
- ✓ Perform the Check the Equipment steps outlined in this manual.
- ✓ Check underneath and around the machine. Make sure all personnel and equipment are clear from the area of operation and equipment movement. Check clearances in all directions, including overhead.
- ✓ Be properly seated in the operator's seat.
- ✓ Do not attempt to operate until you have read and fully understand this manual and the OEM manual for the carrier.

OPERATIONAL SAFETY

Check the Equipment

Before use, check the equipment to ensure it is in good operating condition.

Check the following:

- ✓ Grease fittings. Pump grease at all fitting locations, see page 19.
- ✓ Hydraulic fluid level. Add hydraulic fluid as required.
- ✓ Hydraulic hoses and hose connections for wear or leaks. Repair or replace any damaged hoses or connections.
- ✓ All control levers for proper operation.
- ✓ Rotation bearing. Visually check for loose or damaged bolts. If repair is required, refer to qualified personnel.
- ✓ Grease rotation bearing and pinion gear.
- ✓ Check for loose or missing pin retaining bolts.
- ✓ Check cylinders for dents (barrel) or dings (rod).



**GOOD
CONDITION**



WARNING

Serious injury or death could result if warnings or instructions regarding carrier stability and the work area are not followed properly.

Stability

Your Genesis attachment is sized for carrier stability. However, improper operation, faulty maintenance or unauthorized modifications may cause instability.

- ✓ Know the working ranges and capacities of the carrier to avoid tipping.
- ✓ Use the recommended carrier counter weight.

The following conditions affect stability:

- Ground conditions
- Grade
- Weight of attachment
- Contents of attachment
- Operator judgement



For greater stability, knuckle the attachment to bring the load closer to the center of rotation (center of gravity) while lifting. Use extra caution during reaching to avoid tipping.

OPERATIONAL SAFETY

Know the Work Area

Check clearances in the work area. Keep all bystanders at a safe distance. Do not work under obstacles. Always check your location for overhead and buried power lines or other utilities before operation.

Check ground conditions. Avoid unstable or slippery areas. Position the carrier on firm level ground. If level ground is not possible, position the carrier to use the attachment to the front or back of the carrier. Avoid working over the side of the carrier.

To reduce the risk of tipping and slipping, never park on a grade exceeding 10% (one-foot rise over the span of a ten-foot run).

Starting Procedure

Before operating, walk completely around the equipment to make certain no one is under it, on it or close to it. Keep all bystanders at least 75 feet away from the area of operation and equipment movement. Let all other workers and bystanders know you are preparing to start. DO NOT operate until everyone is clear.

Always be properly seated in the operator's seat before operating any carrier controls.

To start:

- ✓ Make sure all controls are in the center (neutral) position.
- ✓ Be properly seated.
- ✓ Slowly operate all functions to check for proper operation and to bleed air from the hydraulic system.

To shut down:

- ✓ Return your Genesis attachment to a rest position on the ground.
- ✓ Shut off the carrier engine.
- ✓ Work controls in all directions to relieve hydraulic pressure, per excavator manufacturer's instructions.



WARNING

Serious injury or death could result if warnings or instructions regarding safe operation are not followed properly.

Place the Load Safely

Do not move the attachment, or anything held in the jaws, over people, equipment or buildings. Do not throw or drop the contents. Operate the controls smoothly and gradually.

OPERATIONAL SAFETY

Safely Operate Equipment

Do not operate equipment until you are trained by a qualified operator in its use and capabilities.

See your carrier's manual for these instructions.

- ✓ Operate only from the operator's seat. Check the seat belt daily and replace if frayed or damaged.
- ✓ Do not operate this or any other equipment under the influence of drugs or alcohol. If you are taking prescription medication or over-the-counter drugs ask your medical provider whether you can safely operate equipment.
- ✓ Never leave equipment unattended with the engine running or with the attachment in a raised position. Apply the brakes before exiting the equipment.
- ✓ Do not exceed the lifting capacity of your carrier.
- ✓ Avoid conditions that can lead to tipping. The carrier can tip when operated on hills, ridges, banks and slopes. Avoid operating across a slope which could cause the carrier to overturn.
- ✓ Reduce speed when driving over rough terrain, on a slope, or when turning to avoid overturning the carrier.
- ✓ Never use the attachment as a work platform or personnel carrier.
- ✓ Keep all step plates, grab bars, pedals and controls free of dirt, grease, debris and oil.
- ✓ Never allow anyone to be around the equipment when it is operating.
- ✓ Do not operate poorly maintained or otherwise faulty equipment. Inform the proper authority and DO NOT resume operation until the problem has been fixed.
- ✓ Do not alter or remove any safety features.
- ✓ Know your work site safety rules as well as traffic rules and flow. When in doubt on any safety issue, contact your supervisor or safety coordinator for an explanation.
- ✓ A heavy load can cause equipment instability. Use extreme care during travel. Slow down on turns and watch out for bumps. The equipment may need additional counter-weights to counterbalance the weight of the attachment.



OPERATIONAL SAFETY

Transporting the Attachment

- ✓ Travel only with the attachment in a safe transport position to prevent uncontrolled movement. Drive slowly over rough ground and on slopes.
- ✓ When driving on public roads use safety lights, reflectors, Slow Moving Vehicle signs, etc., to prevent accidents. Check local government regulations that may affect you.
- ✓ Do not drive close to ditches, excavations, etc., as cave-in could result.
- ✓ Do not smoke when refueling the prime mover. Allow room in the fuel tank for expansion. Wipe up any spilled fuel. Secure cap tightly when done.

Equipment Condition

Never operate poorly maintained equipment. When maintenance is required, repair or replace parts immediately.



WARNING

Serious injury or death could result if warnings or instructions regarding working overhead are not followed properly.

Working Overhead

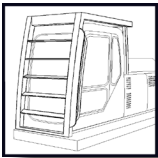

Avoid handling material overhead whenever possible. Safety glass and wire mesh cab guarding must be installed to protect the operator from flying debris that may be created during handling. Falling Object Protection Structures, or FOPS, are necessary for any application where material is to be handled overhead.



DANGER

Serious injury or death will result if warnings or instructions regarding power lines are not followed properly.

Power Lines

Do not operate the machine near energized power lines. All local, state/provincial and federal regulations must be met before approaching power lines, overhead or underground cables, or power sources of any kind with any part of the carrier or attachment. Always contact the appropriate utility when operating near power lines. The lines should be moved, insulated, disconnected or de-energized and grounded before operating in the area.



Current in high voltage lines may arc some distance from the wire to a nearby ground. Keep all parts of the machine at least 50 feet (16m) away from power lines.

OPERATIONAL SAFETY



WARNING

Serious injury or death could result if warnings or instructions regarding hydraulic fluid pressure are not followed properly.

Use Care with Hydraulic Fluid Pressure

Hydraulic fluid under pressure can penetrate the skin and cause serious injury or death. Hydraulic leaks under pressure may not be visible.

- ✓ Keep unprotected body parts, such as face, eyes and arms as far away as possible from a suspected leak. Flesh injected with hydraulic fluid may develop gangrene or other permanent injuries.
- ✓ If injured by injected fluid see a doctor immediately.
- ✓ Wear safety glasses and protective clothing and use a piece of cardboard or wood when searching for hydraulic leaks.

Do Not Use Your Hands!
See illustration below.

- ✓ Hydraulic oil becomes hot during operation. Do not let hydraulic oil or components contact skin, as it could cause severe burns. Allow hydraulic components to cool before working on them. Use appropriate protective clothing and safety equipment. If burned, seek immediate medical attention.

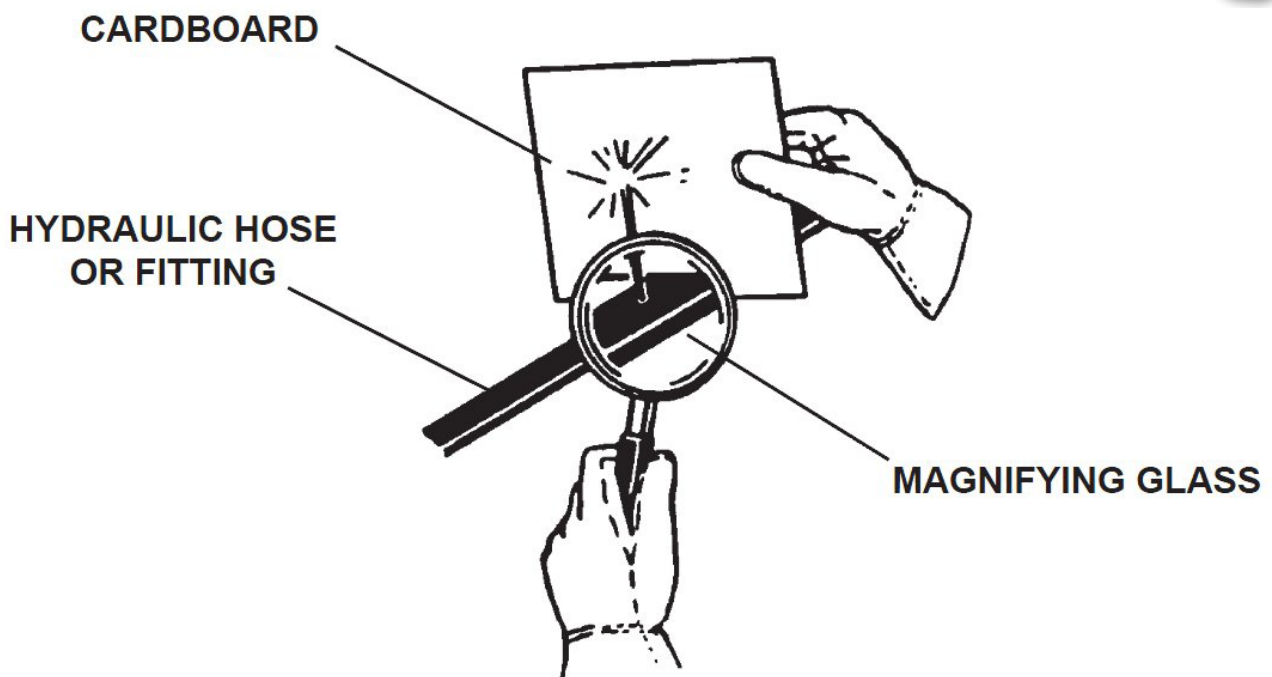

OPERATIONAL SAFETY

Prioritized Oil Flow

Equipment operators must ensure there is prioritized oil flow to the main valves in overhead operations or high reach conditions.

Emergency Situations

Always be prepared for emergencies. Make sure a fire extinguisher is available. Be familiar with its operation. Make sure to inspect and service the fire extinguisher regularly. Make sure a first aid kit is readily available.



Unsafe Conditions

Do not operate if an unsafe condition exists. Stop operation immediately, shut down the machine and report the unsafe condition to the proper authority. Equipment operation and maintenance practices directly affect your safety and the safety of those around you. Always use common sense while operating and be alert to unsafe conditions.

Crystalline Silica Dust

It is recommended to use dust suppression, dust collection and if necessary, personal protective equipment during the operation of any attachment that may cause high levels of dust.

 **DANGER** Exposure to respirable crystalline silica dust along with other hazardous dusts may cause serious or fatal respiratory disease.

IMPORTANT: Concrete and masonry products contain silica sand. Quartz, which is a form of silica and the most common mineral in the Earth's crust, is associated with many types of rock.

Some activities that may have silica dust present in the air include demolition, sweeping, loading, sawing, hammering, drilling or planing of rock, concrete or masonry.

It is recommended to use dust suppression (such as water) or dust collection (such as a vacuum) along with personal protective equipment if necessary during the operation of any attachment that may cause high levels of silica dust.



Prop. 65 Warning for California Residents

 **WARNING** This product may contain chemicals known to the State of California to cause cancer, birth defects, or other reproductive harm. For more information visit: P65Warnings.ca.gov

OPERATIONAL SAFETY



WARNING

Using your Genesis attachment in unauthorized applications may create an unsafe situation and will void the warranty.

Process Material Safely

- Do not pull down structures with your Genesis attachment. Doing so may cause falling debris or material may break free and exceed the capacities of the carrier, causing a tipping hazard.
- The rotator should only be used for positioning your Genesis attachment. Do not use the rotator to pry or break material.

Lift the Load Safely

- The hydraulic system has been preset and tested by your dealer. Do not alter hydraulic settings without consulting an authorized Genesis dealer or the Genesis Service Department. Doing so will void the warranty and may cause structural damage, accidents or tipping.
- Make sure the load is held securely in the tines. Do not move a loaded attachment if load is loose or dangling. Make sure the load is pinched between the tines – never cradle a load.

Place the Load Safely

- Do not move the attachment, or anything held in the tines, over people, equipment or buildings. Place the load gently. Do not throw or drop the contents.
- Operate the controls smoothly and gradually. Jerky controls are hazardous and may cause damage to the carrier.
- Avoid fire hazards. Keep the area clean. Remove all flammable materials from the area during any welding or heating process. Have a fire extinguisher nearby and know how to use it.
- Never substitute pins or bolts. Use factory supplied pins. Replace all bolts with the same size and grade. Failure to do so may cause serious injury or death.
- Use your Genesis attachment only as directed in this manual. Do not use the attachment to lift and move other objects. Doing so may cause instability and tipping.

ATTACHMENT MARKINGS



MAINTENANCE SAFETY

Only trained and authorized persons should perform maintenance on the attachment. To be qualified, you must understand the instructions in this manual, have training, and know the safety rules and regulations of the job site.

Do not alter the physical, mechanical or hydraulic operation of the attachment. Doing so may cause a dangerous situation for yourself and those around you and will void the warranty.

Do not attempt repairs you do not understand. If any questions arise regarding a safety or maintenance procedure, contact Genesis or your Genesis dealer.

Read this entire manual. All personnel must understand the maintenance and safety procedures.

Use factory authorized parts. The use of unauthorized parts may compromise safety, performance and durability of the attachment and may void the warranty.

Follow the daily checklist and maintenance schedules in this manual. Extreme conditions may dictate shorter maintenance intervals.

Do not exceed bolt torque specifications. See the Genesis Fastener Manual.

Do not weld on structural components without consulting Genesis. Doing so may cause structural failure and void the warranty.

Do not operate an attachment without the case-drain line properly installed if the attachment uses a rotation system that requires a case drain. Doing so will cause immediate failure of the rotate motor and gearbox.

Do not work on the attachment before ensuring it will not move. Completely lower the boom to the ground or a rest position and relieve hydraulic pressure.

Never operate poorly maintained equipment. When maintenance is required, repair or replace parts immediately.

Do not operate under unsafe conditions. If an unsafe condition arises during operation, immediately shut down the equipment and report the situation to the proper authority.

Pinch Points & Crush Points

During maintenance or servicing, lifting the attachment by the top pins may cause the attachment to unexpectedly close, creating a crushing point. The grapple and tines must be properly blocked during maintenance. With the grapple hydraulic system drained of oil, this condition may cause the unexpected movement.

Performing Maintenance

Prior to maintenance, make sure the attachment is properly blocked to prevent accidental rotation. Do not rely on the rotation motor or other rotation components to inhibit movement during maintenance or servicing. Always perform appropriate Lockout/Tagout procedures.

MAINTENANCE SAFETY

Do not work on any hydraulic lines or components while they are pressurized. Escaping hydraulic fluid can penetrate the skin, causing serious injury or death. Relieve pressure before performing maintenance. Keep hands and body parts away from pin holes and nozzles, which eject fluids under high pressure. Use a piece of cardboard to search for leaks.



If fluid is injected into the skin, seek medical assistance immediately from a doctor familiar with this type of injury.

NOTICE

See “Use Care with Hydraulic Fluid Pressure”, page 12

Hydraulic oil becomes hot during operation. Do not let hydraulic oil or components contact skin, as it could cause severe burns. Allow hydraulic components to cool before working on them. Use protective clothing and safety equipment.



Remove paint before welding or heating. Hazardous fumes/dust can be generated when paint is heated by welding, soldering or using a torch. Do all work outside or in a well ventilated area and dispose of paint and solvent properly.

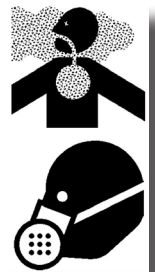

When sanding or grinding paint, avoid breathing the dust. Wear an approved respirator. If you use solvent or paint stripper, remove stripper with soap and water before welding. Remove solvent or paint stripper containers and other flammable materials from area. Allow fumes to disperse at least 15 minutes before welding or heating.

Avoid fire hazards. Keep the area clean. Remove all flammable materials from the area during any welding or heating process. Have a fire extinguisher nearby and know how to use it.



Never substitute pins or bolts. Use factory supplied pins. Replace all bolts with the same size and grade. Failure to do so may cause serious injury or death.

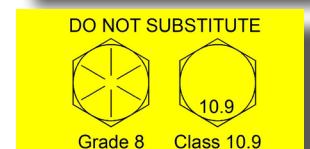

MAINTENANCE SCHEDULE

Performing scheduled maintenance will promote safe, reliable operation of your attachment. Use maintenance procedures described in this manual. If you are not able to safely and competently perform these procedures, have a Genesis dealer perform them.

NOTICE

Extreme operating conditions may require shortened maintenance intervals.

Four-Hour Checklist

Inspect:

- Bolts - check for loose bolts, replace if damaged
- Fittings and hoses for damage or leaks
- Bracket pivot for wear and pin retainers
- Cylinder pivot for wear and pin retainers
- Entire attachment for cracks (visual check)

Grease:

- Cylinder pins (the fittings on the end of the cylinder)
- Pivot pins/drag link pins

Eight-Hour Checklist

Perform four-hour checklist plus the following:

Grease:

- Bracket pivot (stick pin)
- Bracket cylinder(H-link pin)
- Rotation bearing (four locations)
- Rotation bearing gear teeth

Tines:

- Check for loose or damaged bolts, retorquing loose bolts
- Build-up and hard-surface as required

Long-term Maintenance

- Check all bolts, including slewing ring bolts, after the initial 80 hours of operation
- Replace slewing ring bolts every 2000 hours
- Reseal cylinder every 4000 hours
- Reseal swivel every 4000 hours

LUBRICATION POINTS



Shut off excavator and disable hydraulics per OEM instructions before greasing.

For normal conditions above 32°F (0°C), use a lithium-based, premium grade 2 extreme-pressure grease. For temperatures below 32°F, use a grade 0 grease.

Do not use grease containing Molybdenum (Moly).

Genesis GLG-2® anti-wear, extreme-pressure lithium grease, PN 6302601, is recommended for all temperature conditions.

Grease all fittings every four to eight hours of operation (see maintenance schedule). Grease until extrusion is visible.

After greasing the rotation bearing, rotate the attachment through two full rotations. The cylinder and pivot should be greased at four hours and eight hours of operation, while the attachment is warm. The bracket and rotation should be greased at the end of an eight-hour shift.

Grease locations:

1. H-link pin (grease through H-link) - not shown
2. Stick pin - not shown
3. Attachment cylinder rod
4. Attachment cylinder butt
5. Pivot pins
6. Rotation bearing (four locations)
7. Rotation bearing gear teeth
8. Drag link pins

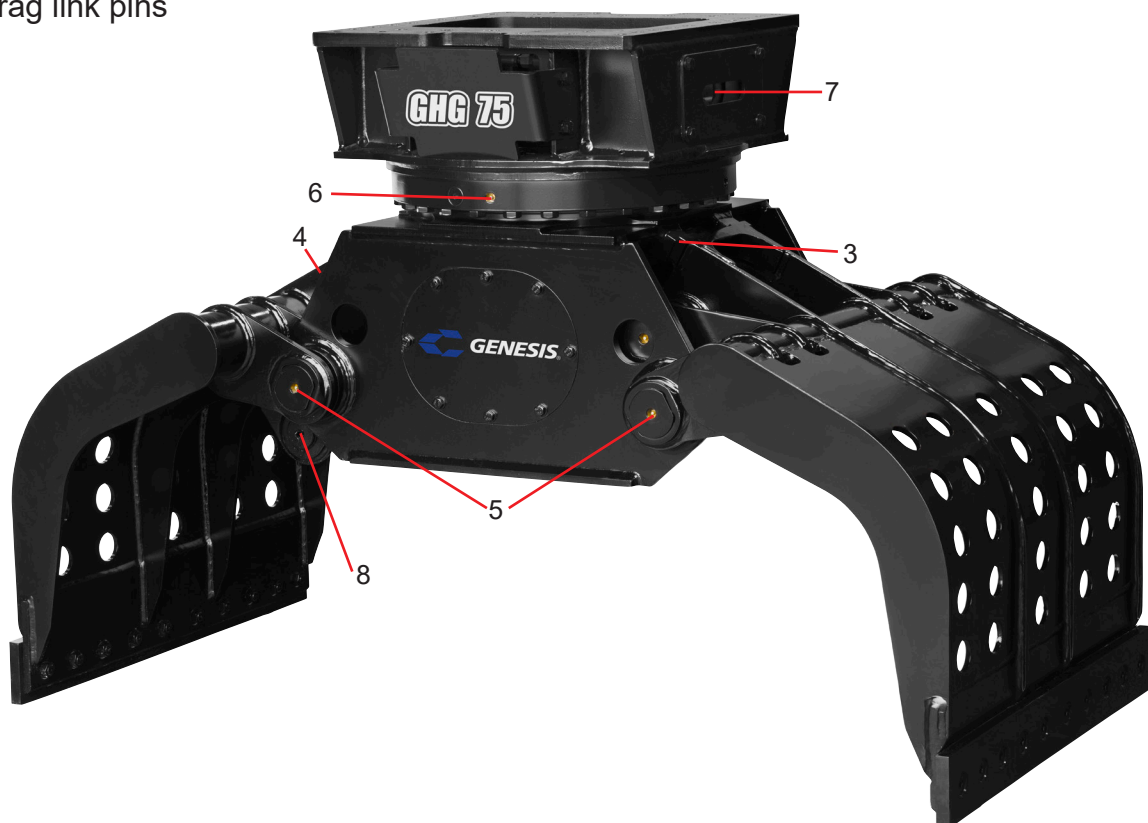

BOLT TORQUE SPECS

**Bolt torque specs and thread treatment procedures can be found in the
Genesis Fastener Manual.**

genesisattachments.com/manuals

GENERAL WELDING GUIDELINES

Build-up and hard-surfacing are welding procedures that protect the parent material of the tines and keep the tool in good condition. Build-up is the welding procedure that restores the tines to their original shape. Building up the jaws helps protect the blades and increases the life of the attachment. Hard-surfacing is the welding material added over the parent material (or build-up material) to create a wear-resistant surface.

Welding should not be performed until the tines are work-hardened. Work-hardening can take up to 80 hours.

Welding Ground Clamp

Disconnect all battery ground cables or shut off master battery switch, if equipped.

Failure to do so may cause excavator electrical problems, including permanent damage to onboard computer systems.

Connect ground clamp as close as possible to the area being welded without allowing current to pass through the pivot pins, cylinder pin, cylinder, swivel, motor or slewing ring.

If you are welding on the frame, connect weld clamp to the frame. If you are welding on the tines, connect to the tines but not to the cylinder clevis. If needed, weld a piece of steel to the area for the grounding clamp and cut the piece off when welding is completed.

Welding Rules

Before you begin:

- Wearing an approved respirator, grind the area to clean it and remove all existing hard-surfacing.
- Preheat area to 350° F (177° C). Maintain this temperature throughout the procedure. Do not exceed 450° F interpass temperature.

During welding:

- Always grind and weld with the grain of the material.
- Peen each weld pass to relieve stress and harden the welds.
- Do not undercut the ends of the welds.

After welding maintenance is complete:

- Cover the area with a heat blanket and allow it to cool slowly, approximately eight hours.
- Do not put the attachment into operation until the welds have been allowed to cool.

BUILD-UP AND HARD-SURFACING

Procedure:

Follow the General Welding Guidelines and Rules.

Determine the area to build up, using a straight-edge or square. Do not allow tines to wear to more than a 3/4" radius on edges of tool.

Build up the tines to slightly higher than the original parent material profile with E7018. Apply single passes in each line with the grain of the steel, peening after each pass.

See drawings for grain, as indicated by arrows. (Red lines indicate hard-surfacing pattern.)

After build-up is complete, grind material to be flush with the flat surfaces of the tool.

Hard-Surfacing Patterns

Where parallel lines are shown, apply single passes approximately 1" apart. Cover exposed faces with a crosshatch pattern with stringer beads at 45° angles to form 1" squares.

Hard-surfacing patterns are indicated by red lines in the drawings. Crosshatch may be used in place of straight stringers on any flat areas of the jaws and on the outside of the upper jaw.

Follow hard-surfacing instructions on the following page.

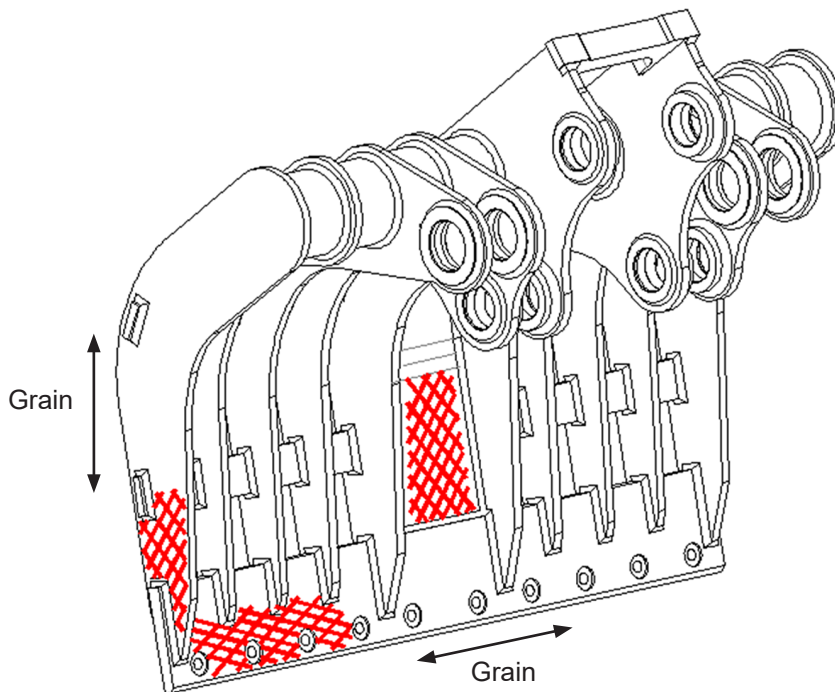

HARD-SURFACING

Do not apply hard-surfacing directly to the parent material as this could cause toe cracking, and the hard-surfacing will break away.

Procedure:

Follow the General Welding Guidelines and Rules.

Apply a single pass stringer bead pattern, with the grain, using E7018 electrode. Peen each pass.

Do not apply a stringer directly on the edge. Start the first pass 1/4" from the edge.

Stagger the ends of the stringer welds so they do not end in a straight line.

Cap each stringer bead with one pass of GenWire or GenRod to hard-surface. Do not apply more than two layers of hard-surfacing. Peen each pass.

Grind the ends of all stringer welds, with the grain to taper 1" to 1-1/2" (25 - 38 mm) to the parent material.

See the previous page for hard-surfacing illustrations and instructions specific to each area of the jaws.

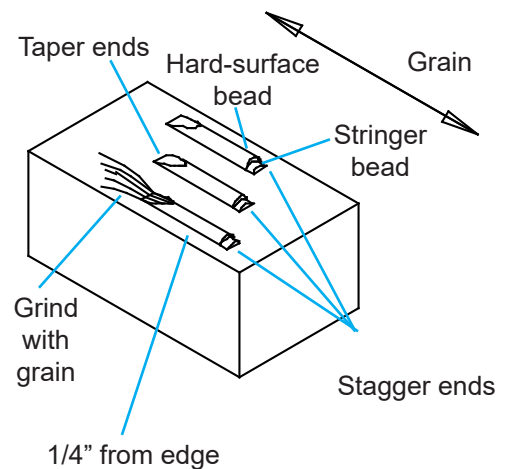

HYDRAULIC/ROTATION MAINTENANCE

Hydraulic Requirements

Operating the attachment below the recommended flow and/or pressure range will adversely affect performance and may damage the rotate motor.

Model	Flow	Pressure
GHG 75	24 GPM 91 LPM	5,000 PSI 345 Bar
GHG 100 & 125	32 GPM 121 LPM	

Operating the attachment above the recommended flow and/or pressure range may damage the attachment and its hydraulic components.

Rotation Valve Input

For cooler and more efficient hydraulic system operation, set the input pressure as indicated in the chart.

Model	Flow	Pressure	Crossover Relief
GHG 75 - 125	11 GPM 42 LPM	2,000 PSI 138 Bar	2,100 PSI 145 Bar

Operating the attachment below the recommended flow and/or pressure range may damage the rotate motor.

Rotation Valve Settings

When checking the crossover relief valve settings, put pressure gauges on both diagnostic ports. Stall attachment rotation in clockwise direction. Increase supply pressure until pressure at gauge on crossover stops rising. This is the crossover relief setting. Increase supply pressure to achieve approved crossover relief value. Repeat procedure in counter-clockwise direction. Then lower supply pressure back to approved value.

SLEWING RING MAINTENANCE

Visually check slewing ring (rotation bearing) bolts every eight hours of operation. Do not reuse or re-torque these bolts. Loose or broken bolts, along with the bolts on either side, must be immediately replaced.

The bolts that secure the slewing ring are critical for safe attachment operation. Improper torque may cause the bolts to fail and the attachment to break free, which may result in serious personal injury and equipment damage. Improper torque will also cause uneven slewing ring wear.

Rotating components must be greased daily. Grease fittings are located on the outside of the slewing ring and on the inside of the rotating head assembly. Grease locations are marked with decals.

Grease each fitting and then rotate the attachment two full rotations.

For normal conditions above 32°F (0°C), use a lithium-based, premium grade 2 extreme-pressure grease. For temperatures below 32°F, use a grade 0 grease. **Do not use grease containing Molybdenum (Moly).**



Genesis GLG-2[®] anti-wear, extreme-pressure lithium grease, PN 6302601, is recommended for all temperature conditions.



Stand clear when the attachment is being rotated. Always stay in clear view of the operator.

ROTATION CIRCUIT

Valves are factory-set and should not need adjustment. If you believe adjustment is necessary, contact the Genesis Service Department.

Note: Genesis does not recommend using the excavator bucket circuit for rotation circuit directional control as it will lead to motor failures.

All rotation circuits use the same procedure for setting flow:

- Rotate attachment, timing one complete revolution.
- Adjust corresponding flow control until revolution time is 8-10 seconds.
- Repeat in opposite direction.

Rotation with Motion Control Valve

Setting the crossover reliefs:

1. Increase supply pressure to the rotation valve to 2600 PSI.
2. Install pressure gauges in feed lines.
3. Secure the attachment from rotating.
4. Pressurize the valve to rotate.
5. Adjust the corresponding relief valve to the pressure specified in the rotation valve settings table.
6. Repeat for the other direction.
7. Reduce supply pressure to the pressure-reducer valve setting specified in the rotation valve settings table.

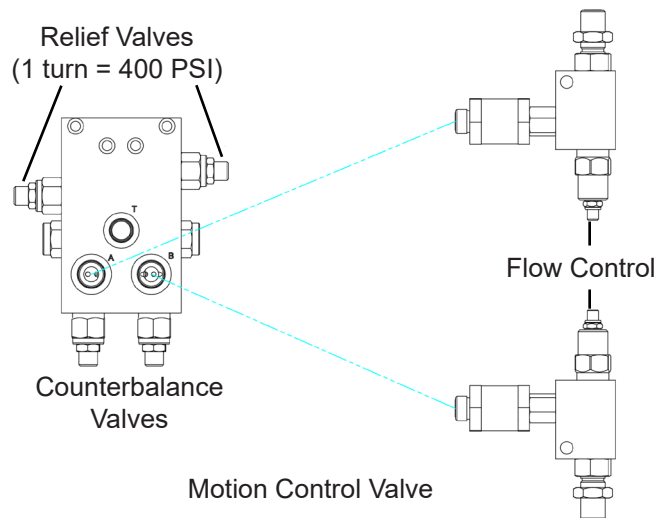

If you cannot reach the pressure specified in the rotation valve settings table, adjust the counterbalance valves using the following procedure:

- Turn the crossover relief valve adjustment screws clockwise to their maximum setting, recording the number of turns so they can later be returned to their original setting.
- Adjust the counterbalance valves by turning the adjustment screws counter-clockwise until the correct setting of 2500 PSI is reached.
- Repeat steps 6 and 7 for setting the crossover reliefs.

If you have questions regarding setting your rotation circuit, please contact the Genesis Service Department.

BLADE MAINTENANCE

Blade Rotation

Rotate blades when the corners are worn down to the tine edge.

End blades can be rotated and exchanged to get four wear edges as described below.

As blade 1 wears:

Rotate 180° to use corner 3.

Exchange to the other end of the tine to use corner 4. Rotate one final time to use edge 2.

The center blade can only be rotated once. This blade typically does not wear as quickly as the two end blades.

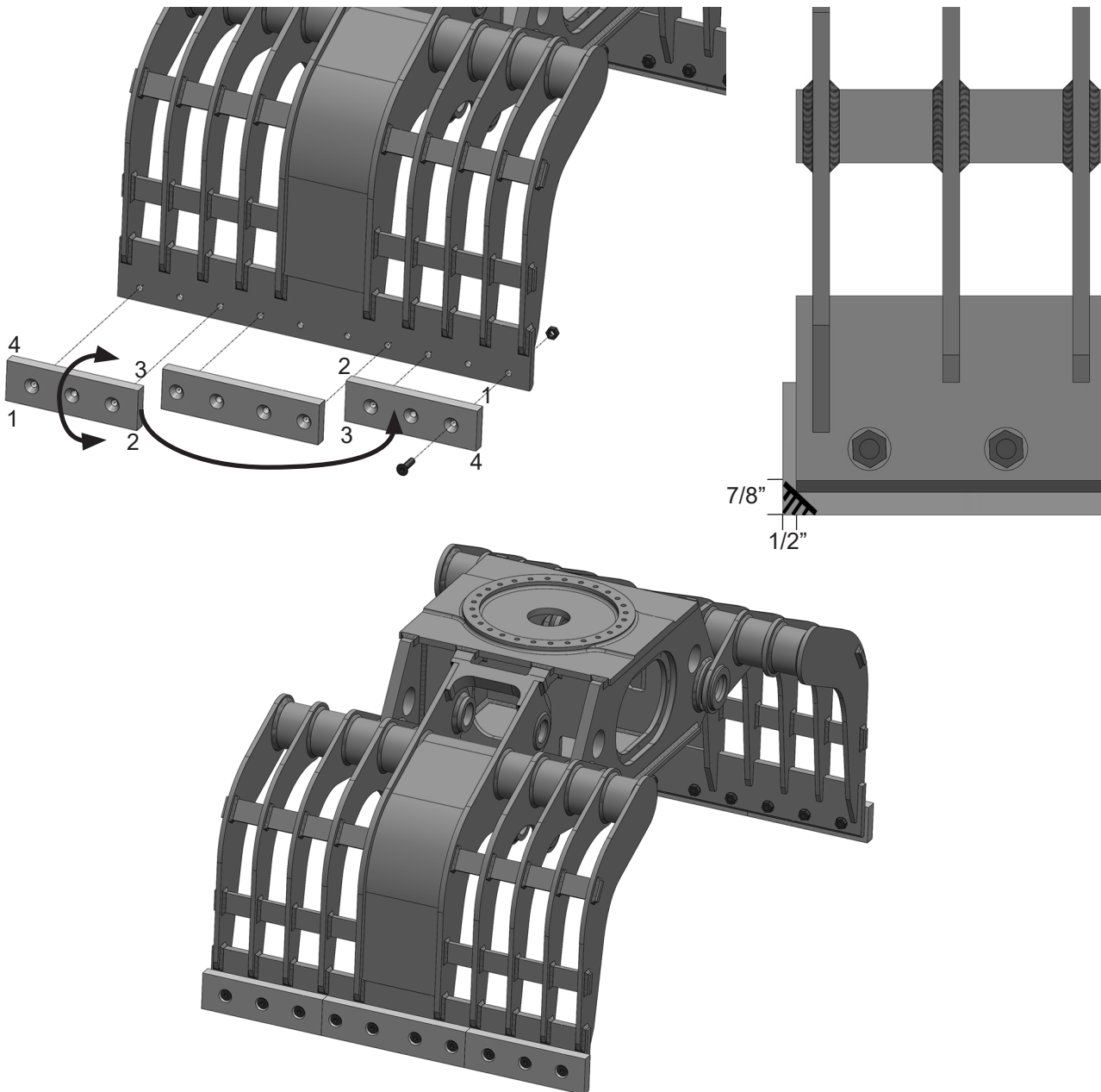

GRAPPLE INSTALLATION

Preparation of the excavator prior to attachment delivery will make installation safer and easier. Contact Genesis or your Genesis dealer for assistance.

Installation Procedure

The attachment is usually shipped in an upright position. Extreme care must be used when positioning the attachment for installation. Typically the grapple is shipped without hydraulic oil in the system. If the grapple is raised but the system is charged, the tines will move/close unexpectedly. Stand clear when raising the grapple for the first time.

Follow the excavator OEM's removal and safety instructions to remove the bucket or other stick attachments.



WARNING

Removing any connecting pin may be hazardous. To remove a connecting pin, position the attachment on the ground and properly support.



WARNING

Particles may fly when a pin is struck. Use a drift pin or mallet when striking pins. Keep all personnel at a safe distance.

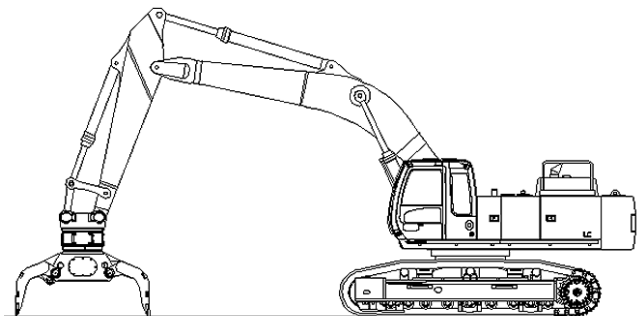
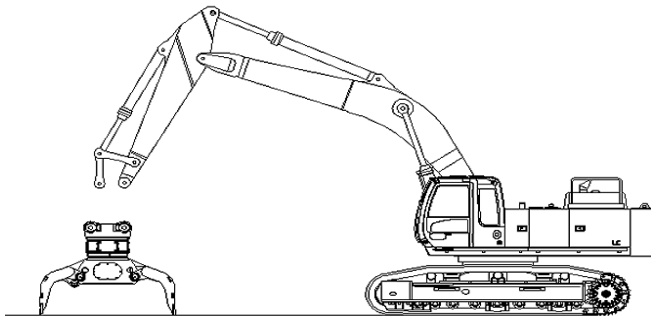

1. Remove both pins from the grapple.
2. With the excavator stick in a vertical orientation, position the excavator over the stick mounting pin. Retract the bucket cylinder to move the H-link out of the way. Carefully lower the stick tip into the GHG lugs and align pin holes. Install the stick pin and cover strap.
3. Slowly extend the bucket cylinder and lower the H-link into the GHG lugs. Align the pin holes and install the link pin and cover strap.
4. Crowd and extend the attachment, checking closely to make sure there is no interference between the attachment bracket and hard lines. Also check for interference between the cylinder and boom/stick.
5. Install excavator hydraulic hoses, supply and return, from the stick tip to the attachment manifold blocks.
6. The stick and bucket circuits are oriented as to rod and bore sides of their respective cylinders. When you connect a circuit to the attachment, take care to connect rod-to-rod and bore-to-bore. When these are reversed, extra pressure is needed to open the jaw, which pulls down the engine, destroys the pumps, increases jaw cycle time, creates high oil temperatures and burns more fuel.

ROTATOR INSTALLATION

The rotator requires an additional hydraulic circuit. These diagrams show the installation of the additional circuit. Refer to the Hydraulic/Rotation Maintenance section of this manual for valve descriptions, functions and settings.

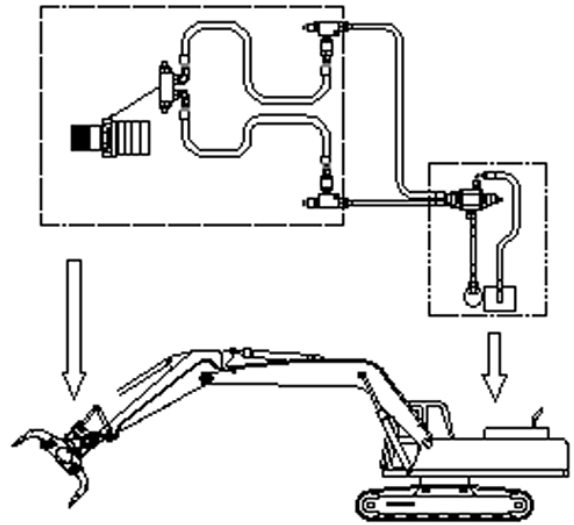
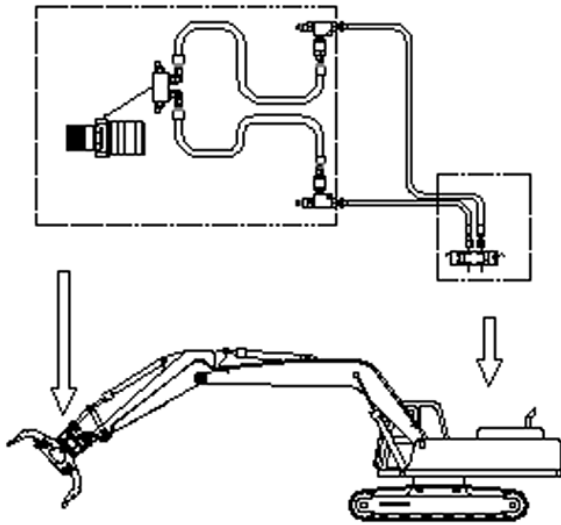

ROTATOR INSTALLATION

Rotation Circuit - Gear Pump Type

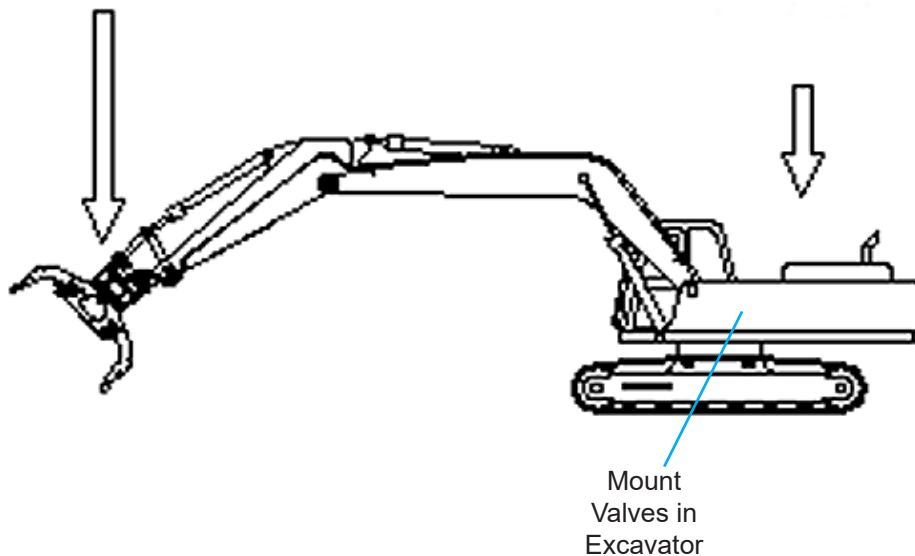
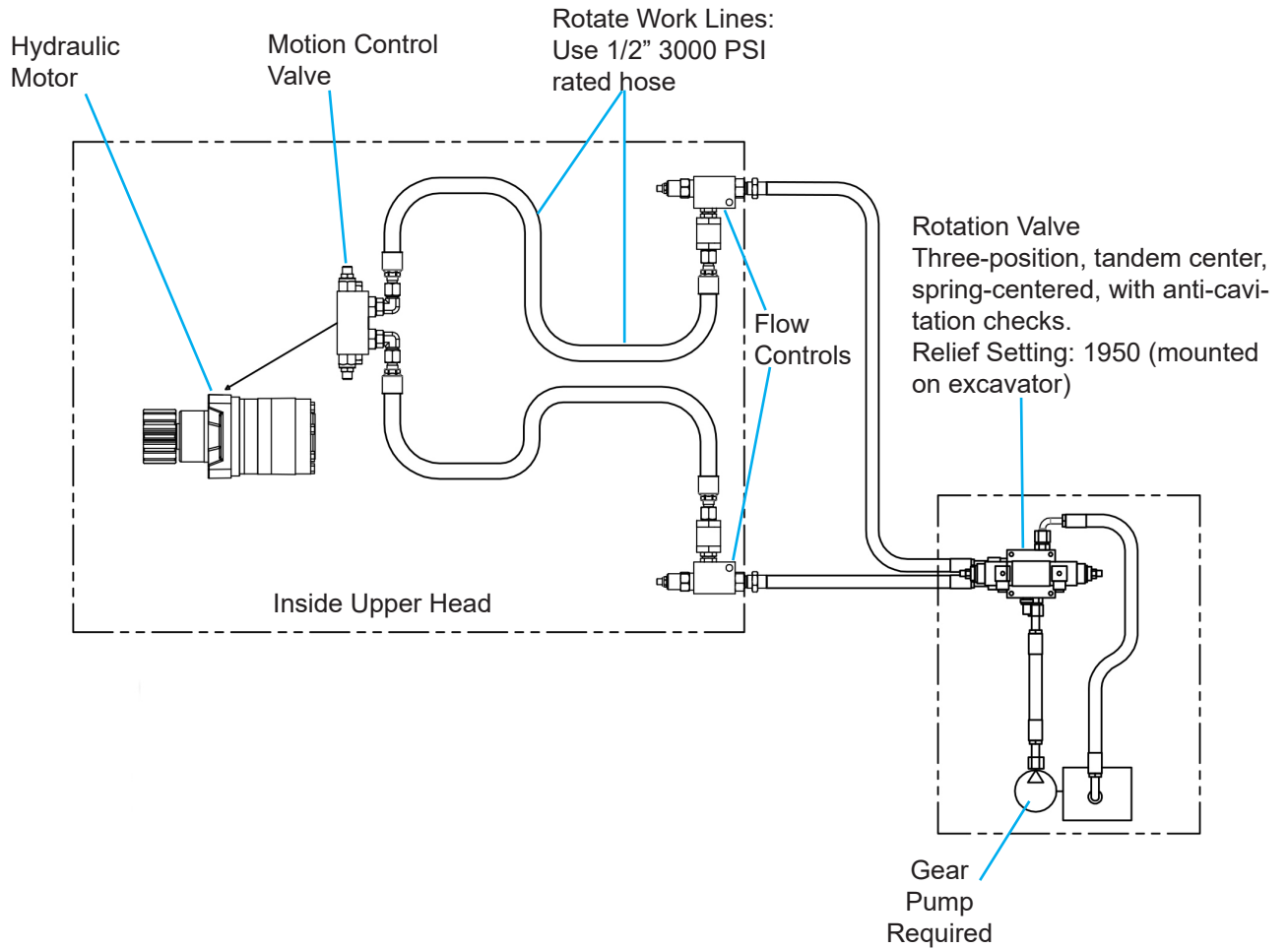

ROTATOR INSTALLATION

Rotation Circuit - Auxiliary Valve on Machine

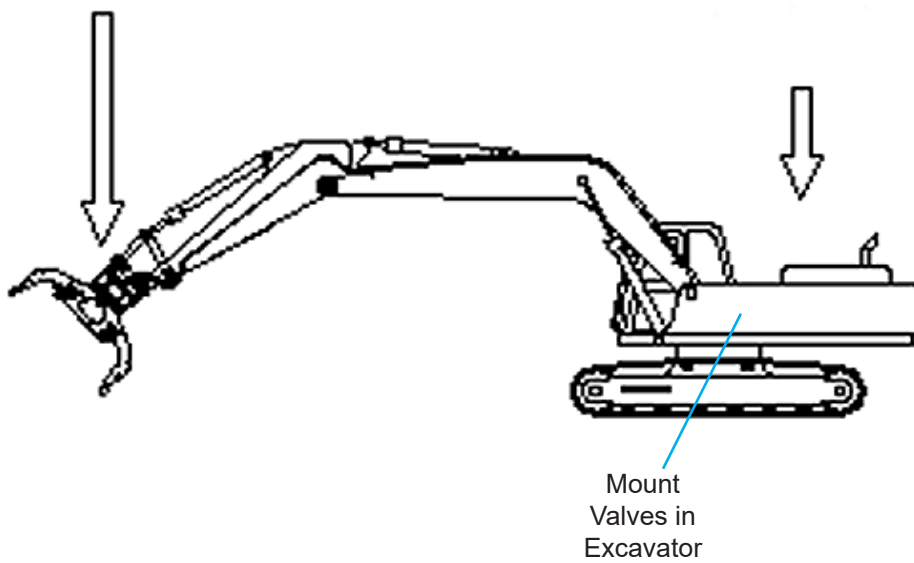
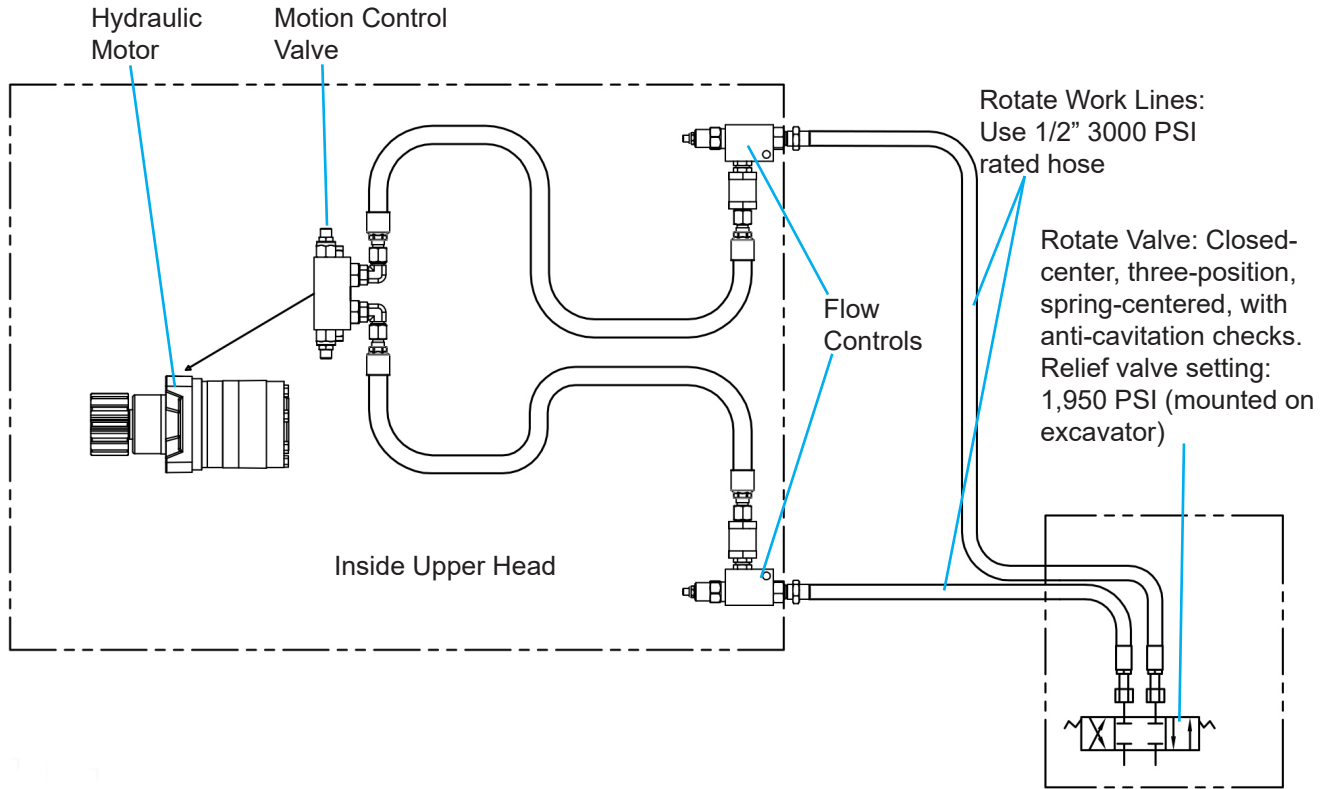

GENERAL OPERATION INSTRUCTIONS

Follow all rules and procedures outlined in the Operational Safety section of this manual.

Use the attachment only as intended, in approved applications, as set forth in this manual.

Do not allow attachment, exposed cylinder rod or hoses to come into contact with any obstacles, buildings or the excavator.

The attachment is not intended to crush or break objects or structures by swinging or dropping the attachment.

NOTICE

When operating in temperatures below freezing, it is also important to process light materials first. This allows the attachment's structural material to "warm up," preventing thermal cracking.

Efficient and Productive Operation

Operators should become accustomed to performing work in the most proficient manner possible.

Material processing areas should be as close as safely possible to the location for loading materials for transportation. Less time spent processing, loading and transporting materials greatly affects operational costs and productivity and dramatically reduces man hours, fuel costs and wear on equipment.

Operators should develop the habit of assessing materials to be processed and visualizing a starting and finishing point to avoid unnecessary cutting/crushing. Excessive moving, positioning and handling cost time and money. Bringing the jaws to full open, when only partial jaw open is needed, wastes time and fuel, slows other excavator functions as well as causes needless wear to hydraulic components, hoses and o-rings. More efficient processing will extend the life of the attachment.

HYDRAULIC START-UP

Genesis grapples are designed to operate under full excavator pressure or up to 5000 PSI. Due to these high pressures, it is important that air is bled from the cylinder after installation. Failure to follow these procedures could result in cylinder seal damage and/or excavator hydraulic system damage.

Start-up Procedure

- ✓ Check the excavator hydraulic tank for proper fluid level.
- ✓ Follow the OEM procedures for starting and warming the excavator hydraulic system. Do not operate the grapple circuit during the warm-up period.
- ✓ After the excavator has reached normal operating temperature, set the engine to idle speed.
- ✓ Slowly fill the bore end of the grapple cylinder to partially close the tines.

NOTICE

Do not fully extend or retract attachment cylinder with the first cycles.

- ✓ Slowly fill the rod end of the grapple cylinder to open the tines. Use partial strokes extending and retracting, slowly working to full strokes.
- ✓ Stop and check the excavator hydraulic fluid level again to be sure there is still sufficient fluid. Service as required.
- ✓ Cycle the tines five or six times before increasing the full operating pressure.

HYDRAULIC / ROTATION MAINTENANCE

Mounting Bolts

Visually check slewing ring (rotation bearing) bolts every eight hours of operation and replace every 2000 hours. Do not reuse or re-torque these bolts. Immediately replace a loose or broken bolt, and replace the bolts on either side of it. Apply Loctite to the bolt threads and under the bolt head per Loctite instructions.

Bolt Torque

The bolts that secure the slewing ring are critical to safe operation of the attachment. Improper bolt torques may cause the bolts to fail and allow the attachment to break free. This may result in serious personal injury and damage to equipment. Improper torques will also cause uneven wear on the slewing ring. See the Genesis Fastener Manual for proper bolt torque specifications.

Grease Slewing Ring

Rotating components must be greased daily. Grease fittings are located on the outside of the slewing ring and on the inside of the rotating head assembly. Grease locations are marked with decals.

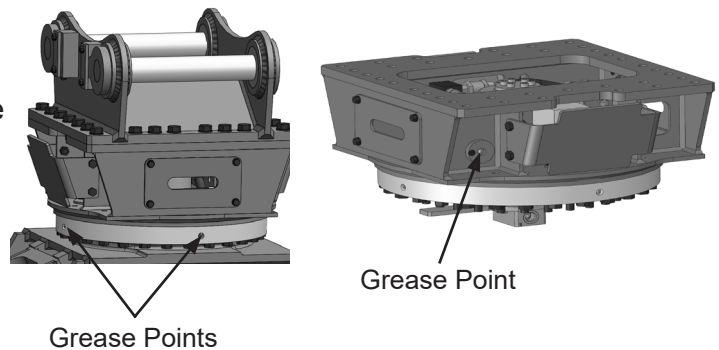

Rotate After Greasing

Grease each slewing ring grease fitting with several strokes and rotate the attachment two full rotations after greasing each fitting.

Grease Points

Grapple pins must be greased every 4 hours.

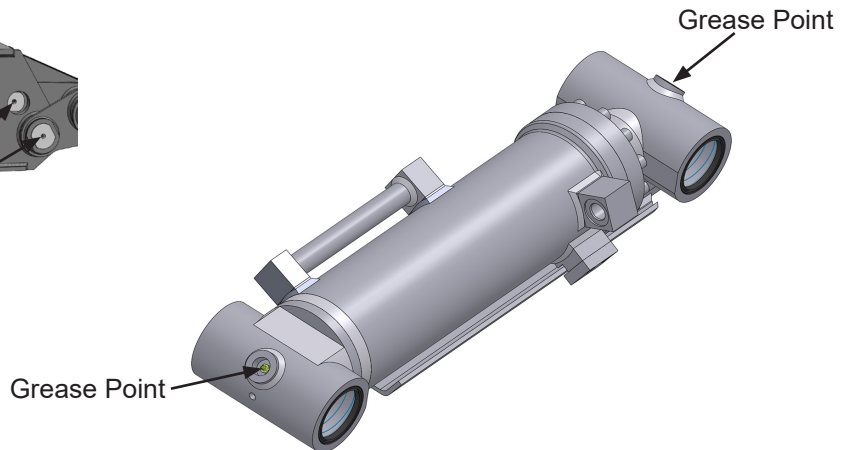
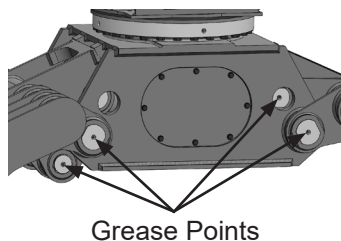

Grease Temperatures

For normal conditions above 32° F (0° C), use a lithium-based, premium grade 2 extreme pressure grease. For temperatures below 32° F, a grade 0 grease is recommended.

TROUBLE-SHOOTING GUIDE

Symptom	Possible Causes	Possible Solutions
Tines lack clamping power	Excavator is not putting out full pressure to the tine circuit	Check excavator circuit relief valve
	Cross-over relief valve setting is too low	Adjust the cross-over relief valves
	Tine cylinder(s) is bypassing internally	Replace cylinder seals
	Swivel is bypassing internally	Replace swivel seals
Tines drift closed	Swivel is bypassing internally	Replace swivel seals
	Tine cylinder(s) is bypassing internally	Replace cylinder seals
Tine closing and opening speed is slow	Flow from excavator is too slow	Check excavator hydraulic system flow
	Swivel is bypassing	Replace swivel seals
	Tine cylinder(s) is bypassing internally	Replace or reseal the cylinder(s)
Grapple rotation is weak	Low supply pressure from the excavator	Check rotation pressure, adjust or replace the relief valve
	Hydraulic motor is worn	Replace hydraulic motor
Grapple rotation is slow	Flow from excavator is too slow	Check excavator hydraulic system flow
	Worn hydraulic motor	Replace the hydraulic motor

TROUBLE-SHOOTING GUIDE

Symptom	Possible Causes/Solutions
Low power	Isolate attachment from excavator and check excavator pressures at boom tip or arm
	Possible cylinder, swivel or bypass (contact Genesis Service Department for procedures)
Slow jaw open with low power	Check for damaged seals
Slow jaw close	Check flows from excavator
Tines close suddenly and will not open	Ball valve may be partially closed on excavator
	Excavator spool may be stuck
	If attachment has quick-coupled hydraulics, they may be partially disconnected or damaged
Does not rotate	Blown fuse
	Test for 24V at plugs on directional valve while depressing foot switch
	Incorrect pressure settings; reset
Does not rotate in one direction	No electrical power to one side; test for 24V at plugs on directional valve while depressing foot switch
	Check if directional control valve shifts both ways while actuating foot switch in both directions
Rotator chatters	Electrical short; back out flow controls
	Pressure settings too high; reset
	Power to both rotation solenoids at the same time; test for 24V at plugs on directional valve while depressing foot switch
Rotates faster in one direction	One flow control cartridge set higher than the other; reset
Rotates too fast or too slow	Flow control out of adjustment; reset
Rotation speed changed from original setting	Jam nut loosened on rotation valve
	Faulty cartridge (contamination)
	Faulty directional control valve
	Pressure set too low; reset

WARRANTY

Claim Procedure

Notify the Genesis Service Department of the potential warranty claim prior to making the repair. Digital pictures are very helpful for diagnosing problems and recommending repairs.

Contact the Genesis Service Department before making alterations, changes or repairs to any component that is going to be considered for warranty. Not doing so will void all Genesis warranty consideration.

The Genesis Service Department will issue an authorization number to track the repair costs, outgoing parts, and/or defective parts returning to the factory.

Replacement parts must be ordered using a purchase order number. Shipping is standard ground. Overnight shipping is available by request, and Genesis will not cover the shipping charge.

When the repair is complete, submit an invoice to the Genesis Service Department within 30 days. Include itemized internal labor reporting, parts lists and invoices for outside contractors. Reference the authorization number on all invoices.

When returning parts for warranty consideration, include a copy of any related Genesis paperwork along with any other necessary documentation to ensure proper processing and credit. The Genesis Service Department will provide the necessary forms.

Your account will be credited when the warranty claim is accepted.

Please direct any questions to the Genesis Service Department: 715-395-5252

PARTS ORDER POLICY AND PROCEDURE

Parts Orders Should Include

- Purchase order number
- Model and serial number of attachment
- Part number and quantity needed
- Shipping and billing address
- Method of shipment or required delivery date

Placing Orders

Orders may be placed by phone or e-mail. To e-mail an order, use the form on the following page or your purchase order form. Contact information is located at the front of this manual.

Part Numbers

Part numbers are listed in a separate Parts Manual or, if included, the Parts section of this manual. Contact the Genesis Parts Department with questions regarding part numbers, availability and pricing.

Shipping

All orders will be shipped best way surface unless an alternate shipping method is requested. Shipping charges are not included in the purchase price of parts.

Invoices

All invoices are due upon receipt. Any accounts with invoices open beyond 60 days are subject to review and may be placed on C.O.D. status without further notice.

Returns

Many unused Genesis parts may be returned with proper documentation. Return shipping is the responsibility of the purchaser. Credit will be issued upon return, less a 25% restocking fee. Documentation is required for credit of returned parts. Contact the Genesis Service Department at 715-395-5252 for an RGA (Return Goods Authorization) number and form. An RGA must accompany every return. Items shipped without an RGA may be returned to sender.

Warranty Returns

All parts returned to Genesis for warranty consideration must be returned with a completed RGA (Return Goods Authorization) provided by the Genesis Service Department. The form needs to be completed in its entirety, including any additional information requested by the Service Department. Return shipping is the responsibility of the sender and will be credited upon claim approval. A determination to accept or deny the claim will be made based upon the information available to Genesis. Warranty on purchased parts other than wear components is 6 months. Genesis does not cover labor costs to replace purchased parts replaced under warranty. There is no warranty period on wear parts or components.



GENESIS®

The Promise of Performance.

CONTACT INFORMATION

Genesis Attachments

1000 Genesis Drive
Superior, WI 54880 USA

Toll Free: 888-SHEAR-IT
(888-743-2748)

Phone: 715.395.5252

E-mail:
info@genesisattachments.com

Europe/Africa/Middle East Genesis GmbH

Teramostrasse 23
87700 Memmingen, Germany

Phone: +49 83 31 9 25 98 0

Fax: +49 83 31 9 25 98 80

genesis-europe.com

E-mail:
info@genesis-europe.com

Asia Pacific Representative Office

24 Upper Serangoon View #12-28
Singapore 534205

Phone: +65 9673 9730

E-mail:
tchoo@genesisattachments.com

Central America & Colombia

Cra 13A #89-38 / Ofi 613
Bogota, Colombia

Phone: +57 1 610 8160 / 795 8747

E-mail:
contact@themsagroup.com

View and download all manuals: genesisattachments.com/manuals
Patents: genesisattachments.com/products/patents

Rev. 11-11-24