



Hydraulic Breaker (GHB) GHB 250 - GHB 750

SAFETY & OPERATOR'S MANUAL



CONTACT INFORMATION

Genesis Attachments

1000 Genesis Drive
Superior, WI 54880 USA

Toll Free: 888-SHEAR-IT
(888-743-2748)

Phone: 715.395.5252

E-mail:
info@genesisattachments.com

Europe/Africa/Middle East Genesis GmbH

Teramostrasse 23
87700 Memmingen, Germany

Phone: +49 83 31 9 25 98 0
Fax: +49 83 31 9 25 98 80
genesis-europe.com

E-mail:
info@genesis-europe.com

Asia Pacific Representative Office

24 Upper Serangoon View #12-28
Singapore 534205

Phone: +65 9673 9730

E-mail:
tchoo@genesisattachments.com

Central America & Colombia

Cra 13A #89-38 / Ofi 613
Bogota, Colombia

Phone: +57 1 610 8160 / 795 8747

E-mail:
contact@themsagroup.com

View and download all manuals: genesisattachments.com/manuals
Patents: genesisattachments.com/products/patents

PREFACE

To ensure years of safe, dependable service, only trained and authorized persons should operate and service your Genesis attachment. It is the responsibility of the product's owner to ensure the operator is trained in the safe operation of the product and has available this manual for review. It is the responsibility of the operator and maintenance personnel to read, fully understand and follow all operational and safety-related instructions in this manual. The attachment should not be operated until you have read and fully understand these instructions. Always use good safety practices to protect yourself and those around you.

Important

This operator's manual must accompany the attachment at all times and be readily available to the operator.

Manual Replacement

Should this manual become damaged or lost or if additional copies are required, immediately contact any authorized Genesis dealer or the Genesis Service Department at 888-743-2748 or 715-395-5252 for a replacement.

Registration Form

The Warranty Registration Form must be filled out by the dealer or customer and returned to Genesis indicating the date the attachment went into service.

Possible Variations

Genesis cannot anticipate every possible circumstance that might involve a potential hazard as the owner's requirements and equipment may vary. Therefore, the warnings in this publication and on the product may not be all-inclusive, and you must satisfy yourself that the procedure, application, work method or operating technique is safe for you and others before operating.

Public Notice

Genesis reserves the right to make changes and improvements to its products and technical literature at any time without public notice or obligation. Genesis also reserves the right to discontinue manufacturing any product at its discretion at any time.

Warranty

All work or repairs to be considered for warranty reimbursement must be pre-authorized by the Genesis Service Department. Any alterations, modifications or repairs performed before authorization by the Genesis Service Department will render all warranty reimbursement consideration null and void without exception. See page 35 for Warranty Claim Procedures.

Improper operation or improperly performed maintenance may render any warranty null and void.

TABLE OF CONTENTS

CONTACT INFORMATION	2
PREFACE	3
Important	3
Manual Replacement	3
Registration Form	3
Possible Variations	3
Public Notice	3
Warranty	3
SAFETY STATEMENTS	6
GENERAL SAFETY PRECAUTIONS	7
Read Manual Prior to Operation	7
Read and Understand All Safety Statements	7
Know Your Equipment	7
Protect Against Flying Debris	7
Lower or Support Raised Equipment	7
Do Not Modify Prime Mover or Attachments	8
Safely Maintain and Repair Equipment	8
Safely Operate Equipment	8
OPERATIONAL SAFETY	9
Use Care with Hydraulic Fluid Pressure	9
Know Where Utilities Are	10
Remove Paint Before Welding or Heating	10
End of Life Disposal	10
Operating the Attachment	11
Transporting the Attachment	12
Maintaining the Attachment	12
Sound and Vibration	12
DECALS	13
Placement and General Information	13
INSTALLATION	14
Installing to Prime Mover	14
Detaching from Prime Mover	14
Tool Style Guide	15
Tool Bit Installation/Removal	16
OPERATION	17
General Information	17
Intended Use	17
Moving Loads	17
Lifting Loads	17
Operating with Cylinders at End Positions	18
Prying Loads	18
Slant Hammering	18
Continuous Hammering	18
Underwater Use	18
Storage	19
Removal from Storage	19

TABLE OF CONTENTS

Lift Points.....	20
Tie Down Points.....	20
Transporting.....	20
MAINTENANCE & SERVICE.....	21
General Information.....	21
Lubrication Specification.....	22
Greasing the Breaker.....	22
Charging Backhead with Nitrogen Gas.....	23
Inspection of Wear Parts.....	24
Accessory Tools.....	25
BOLT TORQUE SPECIFICATIONS.....	26
General Torque Specification Tables.....	26
SAE Bolt Torque Specifications.....	26
Metric Bolt Torque Specifications.....	27
SPECIFICATIONS.....	28
Breaker Torque.....	28
General Dimensions.....	29
Flow Test Procedures.....	32
Heat Load Test.....	33
Troubleshooting.....	33
TROUBLE-SHOOTING GUIDE.....	34
WARRANTY.....	35
Claim Procedure.....	35
PARTS ORDER POLICY AND PROCEDURE.....	36
Parts Orders Should Include.....	36
Placing Orders.....	36
Part Numbers.....	36
Shipping.....	36
Invoices.....	36
Returns.....	36
Return Goods Authorization.....	36
PARTS ORDER FORM.....	37
CONTACT INFORMATION.....	38

SAFETY STATEMENTS



This symbol by itself or used with a safety signal word throughout this manual is used to call attention to instructions involving your personal safety or the safety of others. Failure to follow these instructions can result in injury or death.



This statement is used where serious injury or death will result if the instructions are not followed properly.



This statement is used where serious injury or death could result if the instructions are not followed properly.



This statement is used where minor or moderate injury could result if the instructions are not followed properly.

NOTICE

This statement is used where property damage could result if the instructions are not followed properly.

GENERAL SAFETY PRECAUTIONS

Read Manual Prior to Operation

Improper installation, operation or maintenance of this equipment could result in serious injury or death. Operators and maintenance personnel should read this manual, as well as all manuals related to this equipment and the prime mover thoroughly before beginning installation, operation or maintenance. **FOLLOW ALL SAFETY INSTRUCTIONS IN THIS MANUAL AND THE PRIME MOVER'S MANUAL(S).**

Read and Understand All Safety Statements

Read all safety decals and safety statements in all manuals prior to operating or working on this equipment. Know and obey all OSHA regulations, local laws and other professional guidelines for your operation. Know and follow good work practices when assembling, maintaining, repairing, mounting, removing or operating this equipment.

Know Your Equipment

Know your equipment's capabilities, dimensions and operations before operating. Visually inspect your equipment before you start, and never operate equipment that is not in proper working order with all safety devices intact. Check all hardware to ensure it is tight. Make certain that all locking pins, latches, and connection devices are properly installed and secured. Remove and replace any damaged, fatigued or excessively worn parts. Make certain all safety decals are in place and are legible. Keep decals clean, and replace them if they become worn or hard to read.



WARNING

Serious injury or death could result if warnings or instructions regarding safe operation are not followed properly.

Protect Against Flying Debris

Always wear proper safety glasses, goggles or a face shield when driving pins in or out, or when any operation causes dust, flying debris or any other hazardous material.

Lower or Support Raised Equipment

Do not work under raised booms without supporting them. Do not use support material made of concrete blocks, logs, buckets, barrels or any other material that could suddenly collapse or shift positions. Make sure support material is solid, not decayed, warped, twisted or tapered. Lower booms to ground level or on blocks. Lower booms and attachments to the ground before leaving the cab or operator's station.

GENERAL SAFETY PRECAUTIONS

Do Not Modify Prime Mover or Attachments

Modifications may weaken the integrity of the attachment and may impair the function, safety, life and performance of the attachment. When making repairs, use only the manufacturer's genuine parts, following authorized instructions. Other parts may be substandard in fit and quality. Never modify any ROPS (Roll Over Protective Structure) or FOPS (Falling Object Protective Structure) equipment or device. Any modifications must be authorized in writing by the manufacturer.

Safely Maintain and Repair Equipment

- Do not wear loose clothing or any accessories that can catch in moving parts. If you have long hair, cover or secure it so that it does not become entangled in the equipment.
- Work on a level surface in a well-lit area.
- Use properly grounded electrical outlets and tools.
- Use the correct tools for the job at hand. Make sure they are in good condition for the task required.
- Wear the protective equipment specified by the tool manufacturer.

Safely Operate Equipment

Do not operate equipment until you are completely trained by a qualified operator in how to use the controls, know its capabilities, dimensions and all safety requirements. See your prime mover's manual for these instructions.

- Keep all step plates, grab bars, pedals, and controls free of dirt, grease, debris and oil.
- Never allow anyone to be around the equipment when it is operating.
- Do not allow riders on the attachment or the prime mover.
- Do not operate the equipment from anywhere other than the correct operator's position.
- Never leave equipment unattended with the engine running or the attachment in a raised position.
- Do not alter or remove any safety feature from the prime mover or this attachment.
- Know your work site safety rules as well as traffic rules and flow. When in doubt on any safety issue, contact your supervisor or safety coordinator for an explanation.

OPERATIONAL SAFETY



WARNING

Serious injury or death could result if warnings or instructions regarding hydraulic fluid pressure are not followed properly.

Use Care with Hydraulic Fluid Pressure

Hydraulic fluid under pressure can penetrate the skin and cause serious injury or death. Hydraulic leaks under pressure may not be visible.

- ✓ Keep unprotected body parts, such as face, eyes and arms as far away as possible from a suspected leak. Flesh injected with hydraulic fluid may develop gangrene or other permanent injuries.
- ✓ If injured by injected fluid see a doctor immediately.
- ✓ Wear safety glasses and protective clothing and use a piece of cardboard or wood when searching for hydraulic leaks.

Do Not Use Your Hands!
See illustration below.

- ✓ Hydraulic oil becomes hot during operation. Do not let hydraulic oil or components contact skin, as it could cause severe burns. Allow hydraulic components to cool before working on them. Use appropriate protective clothing and safety equipment. If burned, seek immediate medical attention.

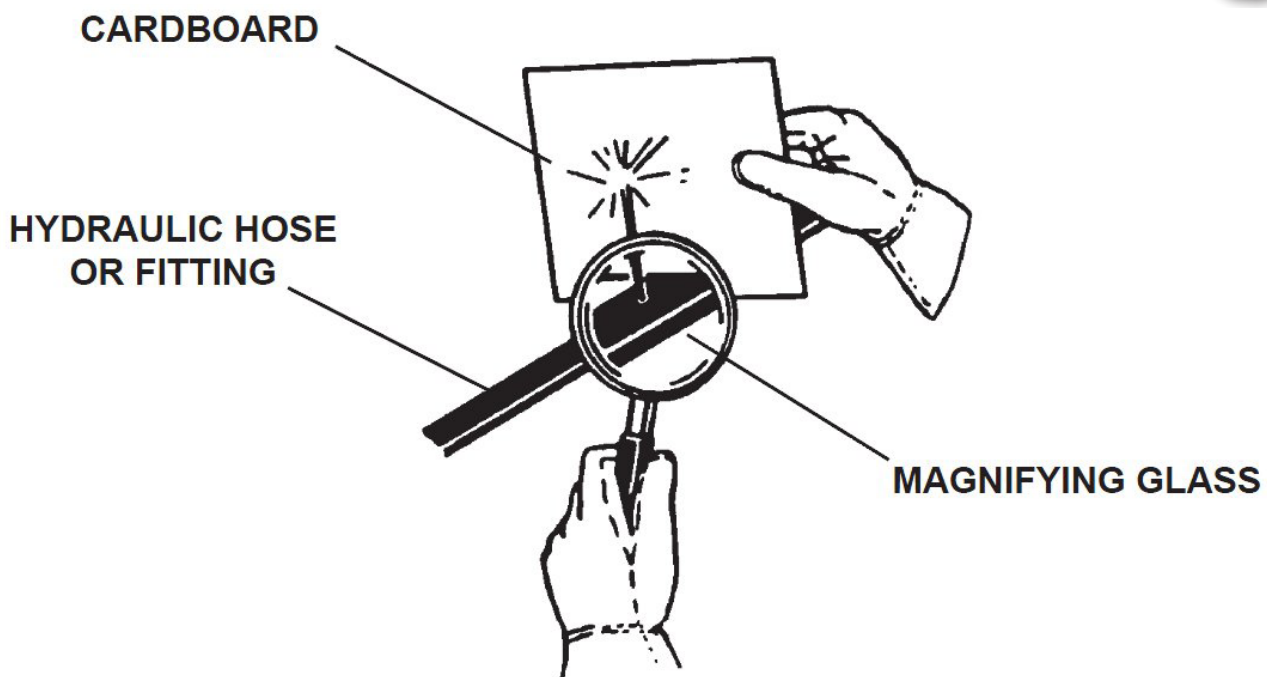

OPERATIONAL SAFETY

Know Where Utilities Are

Observe overhead electrical and other utility lines. Be sure equipment will clear them. When digging, call your local utilities for location of buried utility lines, gas, water and sewer, as well as any other hazard you may encounter.



Exposure to respirable crystalline silica dust along with other hazardous dusts may cause serious or fatal respiratory disease.

It is recommended to use dust suppression, dust collection and if necessary personal protective equipment during the operation of any attachment that may cause high levels of dust.

Remove Paint Before Welding or Heating

Hazardous fumes/dust can be generated when paint is heated by welding, soldering or using a torch. Do all work outside or in a well ventilated area, and dispose of paint and solvent properly. Remove paint before welding or heating.

When sanding or grinding paint, avoid breathing the dust. Wear an approved respirator. If you use solvent or paint stripper, remove stripper with soap and water before welding. Remove solvent or paint stripper containers and other flammable material from area. Allow fumes to disperse at least 15 minutes before welding or heating.

End of Life Disposal

At the completion of the useful life of the unit, drain all fluids and dismantle by separating the different materials (rubber, steel, plastic, etc.). Follow all federal, state and local regulations for recycling and disposal of the fluid and components.

OPERATIONAL SAFETY

Operating the Attachment

- Block off work area from bystanders, livestock, etc. Flying debris can cause severe injury or death. The breaker is capable of producing large amounts of flying debris in all directions.
- Let others know when and where you will be working. Make sure no one is behind the equipment or for several hundred feet in any direction around the equipment when in operation. Never allow anyone to approach the breaker when in operation.
- Do not operate breaker on a prime mover without top and front guard shields or FOPS (Falling Object Protective Structure) installed.
- Do not exceed rated operating capacity of prime mover.
- Operate only from the operator's station.
- When operating on slopes, drive up and down, not across. Avoid steep hillside operation, which could cause the prime mover to overturn.
- Reduce speed when driving over rough terrain, on a slope, or turning, to avoid overturning the vehicle.
- Never lift, move, or swing a load or attachment over anyone.
- Do not lift loads in excess of the capacity of the prime mover. Lifting capacity decreases as the load is moved further away from the unit.
- When using breaker with a quick coupler, operator should check total working weight, including weight of the coupler. Always make sure coupler is securely locked on attachment before use.
- The attachment should not be used as a parking brake to immobilize your prime mover or used in any way to assist in moving your prime mover. Follow the instructions in your prime mover operator's manual before leaving the operator's station.
- An operator must not use drugs or alcohol, which can change his or her alertness or coordination. An operator taking prescription or over-the-counter drugs should seek medical advice on whether or not he or she can safely operate equipment.
- Before exiting the prime mover, lower the attachment to the ground, apply the brakes, turn off the prime mover's engine and remove the key.



WARNING

Using your Genesis attachment in unauthorized applications may create an unsafe situation and will void the warranty.

OPERATIONAL SAFETY

Transporting the Attachment

- Travel only with the attachment in a safe transport position to prevent uncontrolled movement. Drive slowly over rough terrain and slopes.
- When transporting on a trailer secure attachment at recommended tie down locations using tie down accessories that are capable of maintaining attachment stability.
- When driving on public roads use safety lights, reflectors, Slow Moving Vehicle signs etc., to prevent accidents. Check local government regulations that may affect you.
- Do not drive close to ditches, excavations, etc., as a cave-in could result.
- Do not smoke when refueling the prime mover. Allow room in the fuel tank for expansion. Wipe up any spilled fuel. Secure cap tightly when done.

Maintaining the Attachment

- Before performing maintenance (unless otherwise specified), lower the attachment to the ground, apply the brakes, turn off the engine and remove key.
- Always choose hard, level ground to park the vehicle on and set the brake so the unit cannot roll.
- Never perform any work on the attachment unless you are authorized and qualified to do so. Always read the operator service manuals before any repair is made. After completing maintenance or repair, check for correct functioning of the attachment. If not functioning properly, always tag “DO NOT OPERATE” until all problems are corrected.
- Worn, damaged, or illegible safety decals must be replaced. New safety decals can be ordered from your local dealer or the manufacturer.
- Never make hydraulic repairs while the system is under pressure. Serious personal injury or death could result.
- Never work under a raised attachment.
- Only minor maintenance, such as cleaning and lubricating, is required to keep the attachment in top working condition.
- Unless noted otherwise, right and left sides are determined from the operator’s control position when facing forward.
- The illustrations and data used in this manual were current at the time of publishing. However, we reserve the right to redesign and change the attachment as may be necessary without notification.
- Use only manufacturer replacement parts. Substitute parts may not meet the required standards. The parts department will need your product’s model and serial number.

Sound and Vibration

Sound pressure levels and vibration data for this attachment are influenced by many different parameters; some items are listed below (not inclusive):

- prime mover type, age condition, with or without cab enclosure and configuration
- operator training, behavior and stress level
- job site organization, working material condition and environment

Based on the uncertainty of the prime mover, operator and job site it is not possible to get precise prime mover and operator sound pressure levels or vibration levels for this attachment.

DECALS

Placement and General Information

The following diagram(s) show the location of the decals used on your attachment. The decals are identified by their part numbers, with reductions of the actual decals shown on the following pages. Use this information to order replacements for lost or damaged decals. Be sure to read all the decals before operating coupler. They contain information you need to know for both safety and product longevity.

IMPORTANT: Keep all safety decals clean and legible. Replace all missing, illegible or damaged safety decals. When replacing parts with safety decals attached, the safety decals must also be replaced.

REPLACING SAFETY DECALS: Clean the area of application with nonflammable solvent, then wash the same area with soap and water. Allow surface to fully dry. Remove the backing from the safety decal, exposing the adhesive surface. Apply the safety decal to the position shown in the diagram above and smooth out any bubbles.

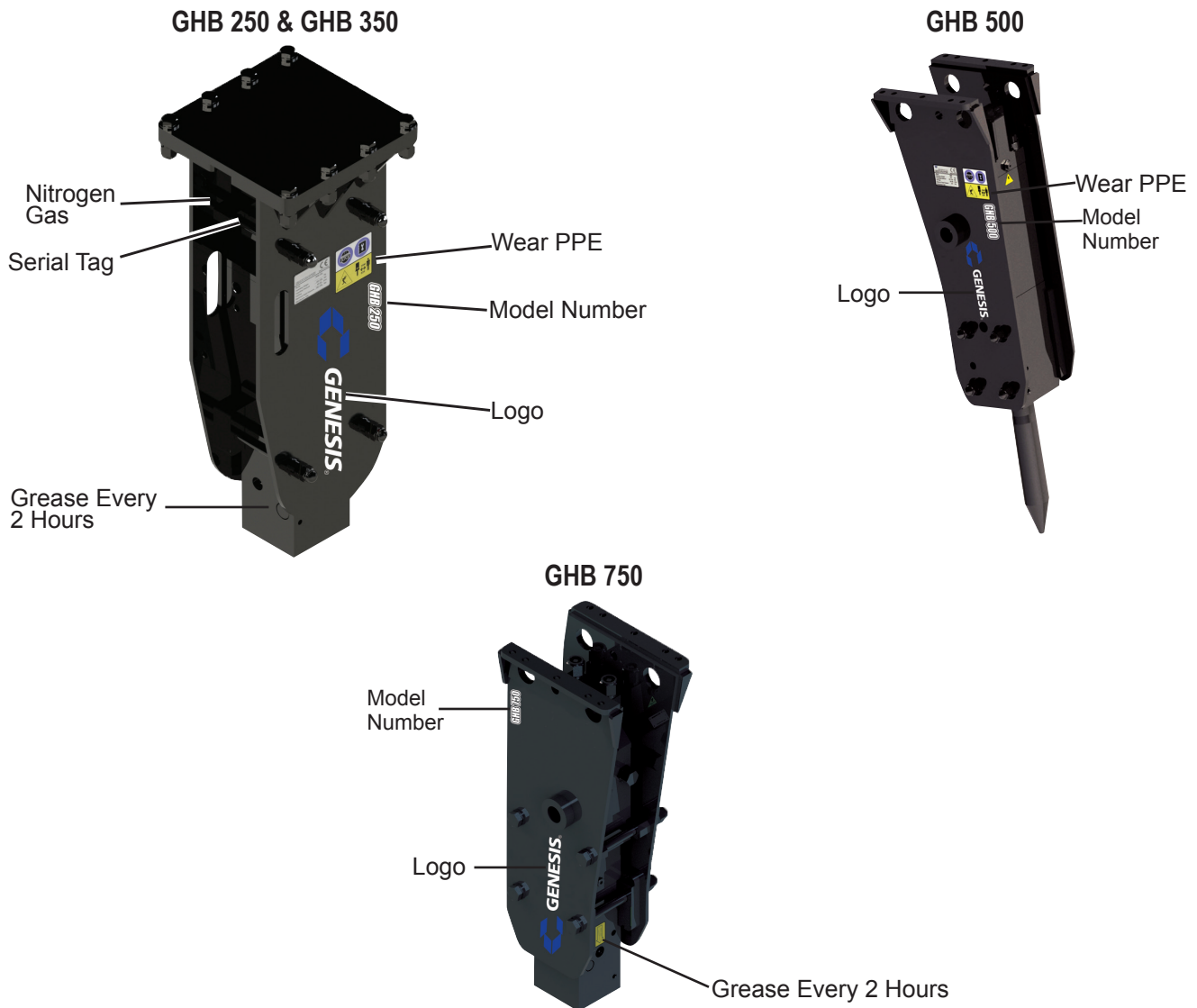

INSTALLATION

Genesis hydraulic breakers are designed to be easy to use and maintain. They are operated by the prime mover's auxiliary hydraulics. Due to the various prime movers that these attachments can be mounted on, all breakers, except the GHB 500 and GHB 750, are shipped without hydraulic hoses or couplers. These can be purchased from your local dealer. The hoses must be long enough not to bind or pinch during operation and rated for the maximum hydraulic pressure of your prime mover's hydraulic system. See Specifications section for hose size requirements.



WARNING

The prime mover must be equipped with an operator enclosure that will provide a safe operating environment whenever working with material or objects that may intrude into the operator's station.

Installing to Prime Mover

1. Remove any attachment from the front of the loader.
2. Following all standard safety practices and the instructions for installing an attachment in your prime mover operator's manual, install the attachment onto your loader.



WARNING

To avoid serious personal injury, make sure the attachment is securely latched to the attachment mechanism of your unit. Failure to do so could result in separation of the attachment from the unit.

3. Lower the unit to the ground and relieve pressure to the auxiliary hydraulic lines.
4. Following the safety shut down procedure for your prime mover, shut down and exit the prime mover.
5. After making sure that the hydraulic lines are free from any foreign material or contaminants, connect the couplers to the auxiliary hydraulic system of your prime mover.
6. Following the standard start up procedure for your prime mover, start the loader and run the attachment to purge any air from the system. Check for proper hydraulic connection, hose routing and hose length.
7. Attachment installation is complete.

Detaching from Prime Mover





1. Before exiting the prime mover, lower attachment to the ground, apply the brakes, turn off the prime mover's engine and remove the key.
2. Follow prime mover operator's manuals to relieve pressure in the hydraulic lines.
3. Disconnect couplers and connect them together or install dust caps and plugs to prevent contaminants from entering the hydraulic system. Store hoses on attachment, off the ground.
4. Follow your prime mover operator's manual for detaching (removing) an attachment.

INSTALLATION





Tool Style Guide

The chart below shows the various types of tools available for use with your hydraulic breaker. Choose the style tool that best fits your application.

Tool Type	Applications
Conical Moil	Very good penetration Soft and non-abrasive rock General demolition
Pyramidal Moil	Maximum penetration Soft and non-abrasive rock
Chisel	Medium penetration Non-abrasive, ductile rock
Blunt	Very good energy transfer Hard and abrasive rock Secondary breaking

Tool Type	Shape	Length inches (mm)			
		GHB 250	GHB 350	GHB 500	GHB 750
Conical Moil		19.6 (500)	22.8 (580)	24.33 (618)	27.5 (697)
Pyramidal Moil					
Chisel					
Blunt					

INSTALLATION

Tool Type	Shape	Weight lbs (kg)			
		GHB 250	GHB 350	GHB 500	GHB 750
Conical Moil		9.7 (4.4)	20.9 (9.5)	34 (15.4)	38.75 (17.6)
Pyramidal Moil		9.7 (4.4)	21.1 (9.6)	33.75 (15.3)	37.5 (17)
Chisel		9.9 (4.5)	21.6 (9.8)	35.25 (16)	38.5 (17.5)
Blunt		10.3 (4.7)	22.9 (10.4)	37.5 (17)	41.25 (18.7)

Tool Bit Installation/Removal

- Lower breaker to the ground and place on wood blocks, making sure it is on a level surface.
- Insert a 10mm bar in direction of arrow and strike with hammer to remove the spring pin (1).
- With spring pin removed, remove the tool pin (2).
- Insert tool bit (3) and reinstall tool pin and spring pin.
- Grease tool before use. Reference the Maintenance and Service section for lubrication specifications.

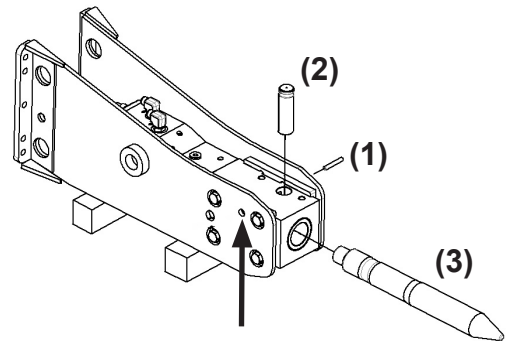

OPERATION

General Information

The hydraulic breaker attaches to the attachment mounting mechanism of your prime mover. Due to this arrangement, thorough knowledge of your prime mover is necessary for machine operation. Read and understand your prime mover's operator's manual before attempting to use the breaker.

Before operating the breaker, check the Specifications section of this manual for correct size of prime mover, hydraulic flow and pressure requirements. Check that the relief pressure setting is within the specification range for your breaker model. If the relief pressure is not correct, adjust the relief valve accordingly.

Also check that oil flow, at the specified operating pressure, is within the specification range for your breaker model. If the prime mover has an oil flow control valve, adjust the control valve accordingly so the oil flow is within the specified range.

NOTE: Always install a flow meter between the breaker inlet and outlet hoses when setting hydraulic flow and pressure. Do not rely on prime mover gauges.

If the breaker is used with a prime mover exceeding the specifications in this manual, the tool warranty is void.

The breaker has been properly charged with nitrogen at the factory and is ready for use.

Intended Use

The Genesis hydraulic breaker is designed as a demolition tool for breaking up hard materials such as rock or concrete. Use in any other way is considered contrary to the intended use.

Some examples of misuse include, but are not limited to, the following:

Moving Loads

Do not move objects with the breaker. Moving objects with any part of the breaker may cause equipment damage.

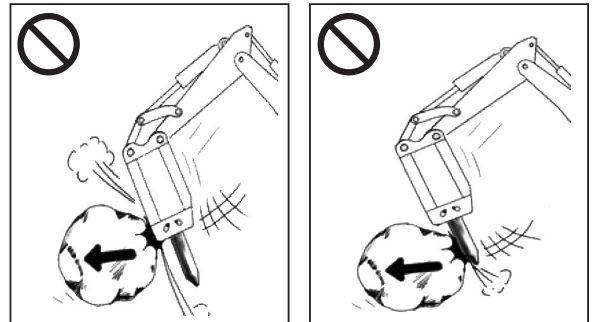

Lifting Loads

Do not lift loads with the breaker. Lifted loads may fall causing serious injury or death.

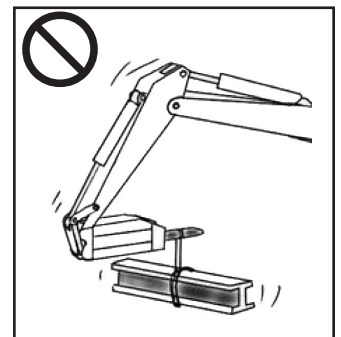

OPERATION

Operating with Cylinders at End Positions

Do not operate breaker with prime mover arm and bucket cylinders in the fully extended or fully retracted position. Doing so may cause damage to the cylinders.

Prying Loads

Do not use demolition tool as a pry bar. Doing so may cause premature wear of the tool bushings and possible failure of the breaker.

Slant Hammering

Always keep breaker at a 90 degree angle to the material while in use. Slant hammering will add stress and bending force to the demolition tool and tool bushings, which may cause premature wear and possible failure of the breaker.

Continuous Hammering

Do not keep breaker on same spot for more than 15 seconds while in use. Doing so will cause the demolition tool to become hot, causing it to soften which may cause the end to mushroom.

Underwater Use

Do not operate breaker under water without supplied air pressure setting. Doing so will cause damage to the breaker. Before using breaker under water, contact dealer for instructions.

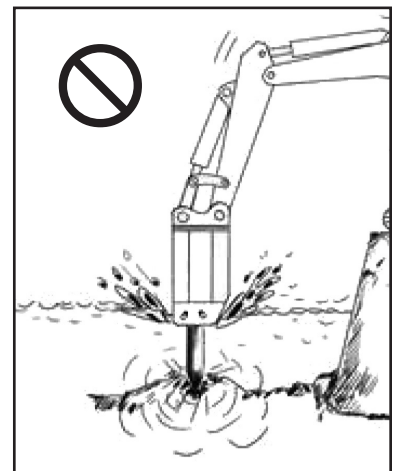
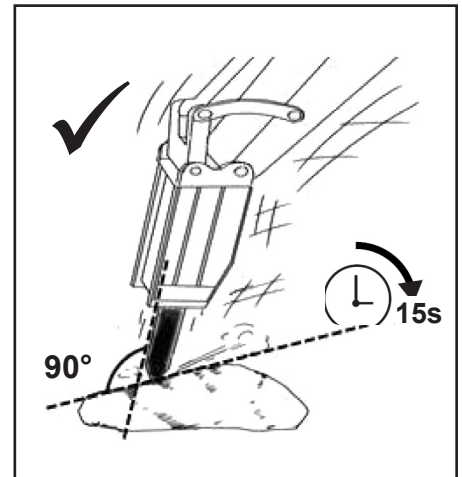
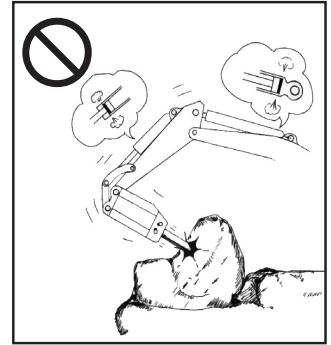

OPERATION

Storage

- Remove breaker from prime mover.
- Clean the unit thoroughly, removing all mud, dirt and grease.
- Inspect for visible signs of wear, breakage or damage. Order any parts required and make the necessary repairs to avoid delays upon removal from storage.
- Tighten loose nuts, capscrews and hydraulic connections.
- Seal hydraulic system from contaminants and secure all hydraulic hoses off the ground to help prevent damage.
- Remove the tool and apply grease to piston bottom, tool bushing, tool pin and inside of front head. After sufficient greasing, reinstall the tool and cover with a waterproof tarp.
- Store unit in a dry and protected place. Leaving the unit outside will materially shorten its life.

Additional Precautions for Long Term Storage (longer than one month):

- Store the breaker in a storage stand.
- Relieve gas pressure from back head.
- Push piston up into cylinder.
- Seal the high pressure supply port with plug.
- Touch up all unpainted surfaces with paint to prevent rust.

Removal from Storage

- Remove cover.
- Wash unit and replace any damage and/or missing parts.
- Lubricate grease fittings.
- Check hydraulic hoses for damage and replace as necessary.

OPERATION

Lift Points

Lifting points are identified by lifting decals where required. Lifting at other points is unsafe and can damage attachment. Do not attach lifting accessories around cylinders or in any way that may damage hoses or hydraulic components.

- Attach lifting accessories to unit at any recommended lifting points.
- Bring lifting accessories together to a central lifting point.
- Lift gradually, maintaining the equilibrium of the unit.



WARNING

Use lifting accessories (chains, slings, ropes, shackles and etc.) that are capable of supporting the size and weight of your attachment. Secure all lifting accessories in such a way to prevent unintended disengagement. Failure to do so could result in the attachment falling and causing serious personal injury or death.

Tie Down Points

Tie down points are identified by tie down decals where required. Securing to trailer at other points is unsafe and can damage attachment. Do not attach tie down accessories around cylinders or in any way that may damage hoses or hydraulic components.

- Attach tie down accessories to unit at any recommended tie down points.
- Check unit stability before transporting.



WARNING

Verify that all tie down accessories (chains, slings, ropes, shackles and etc.) are capable of maintaining attachment stability during transporting and are attached in such a way to prevent unintended disengagement or shifting of the unit. Failure to do so could result in serious personal injury or death.

Transporting

Follow all local government regulations that may apply along with recommended tie down points and any equipment safety precautions at the front of this manual when transporting your attachment.

MAINTENANCE & SERVICE

General Information

Regular maintenance is the key to long equipment life and safe operation. Maintenance requirements have been reduced to an absolute minimum. However it is very important that these maintenance functions be performed as described below. Read and follow all safety precautions before performing any maintenance or troubleshooting on this equipment.

Procedure	Daily	Weekly	Monthly	6 Months
Grease demolition tool every 2 hours.	✓			
Check tightness of hydraulic hoses. Retighten if needed.	✓			
Check for oil leaks and consult with dealer for further inspection.	✓			
Check tightness of side rods. Retighten if needed.		✓		
Check tightness of housing joint bolts and top cover bolts. Retighten if needed.		✓		
Check for damaged or missing bushings, pins, plugs and snap rings. Replace if needed.		✓		
Check for cracks in the housing and top bracket.		✓		
Check gas pressure in the back head and recharge if needed.		✓		
Check wear of demolition tool, tool pins and tool bushings. Replace if wear exceeds acceptable limit.			✓	
Check damping elements and wear plates for wear. Replace if wear exceeds maximum clearance limit.			✓	
Check oil filter of prime mover and replace if needed.			✓	
Check if every part of the power cell is in good condition.				✓
Check torque of every bolt and nut.				✓
Check seals. Replace if needed.				✓

Important: When replacing parts, use only factory approved replacement parts. Manufacturer will not claim responsibility for use of unapproved parts or accessories, and/or other damages as a result of their use.

MAINTENANCE & SERVICE

Lubrication Specification

An NLGI Grade 2 lithium grease with molybdenum disulfide additives and high dropping point (260° C, 500° F) is recommended. Temperature range of -30° C~230° C (-20° F~450° F) is desirable.

Greasing the Breaker

To keep the attachment in proper working condition, it must be greased on a daily basis. Grease points on the attachment are as shown. If any grease fitting(s) are missing or damaged, replace and grease. Metal to metal contact causing pick up may cause deep damage marks, which could lead to the formation of fatigue cracks and eventual failure of the demolition tool.

The demolition tool should be greased every two hours. Make sure the tool shank is well lubricated (5-10 strokes from grease gun to both upper and lower tool bushings should be enough). Do not over grease.

Notice: Make sure the demolition tool is firmly pressed into the front head while greasing. Not doing so may allow grease to fill space between piston and demolition tool, which could cause damage to seals at the lower cylinder, due to its pressurization, and also contaminate the hydraulic oil.

GHB 250, GHB 350 & GHB 750

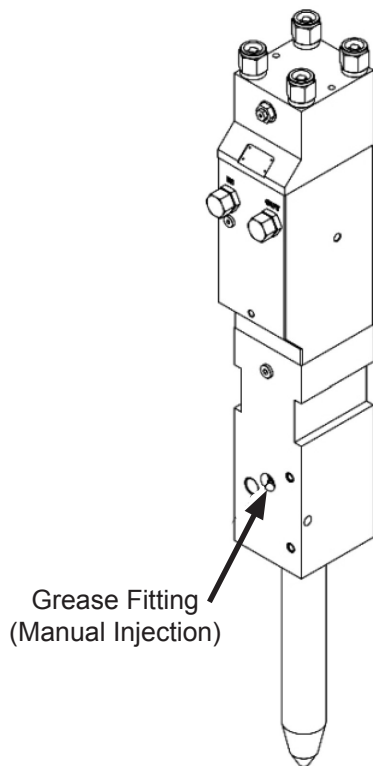

GHB 500

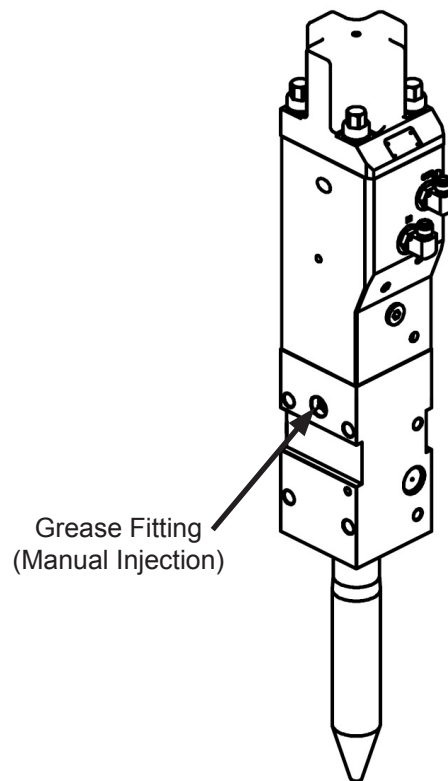

MAINTENANCE & SERVICE

Before performing maintenance or service, lower the attachment to the ground, disengage auxiliary hydraulics, turn off the engine, remove the key and apply the brakes.

WARNING

Never perform any work on this attachment unless you are authorized and qualified to do so. Always read the operator's manuals before any repair is made. After completing maintenance or service, check for correct functioning of the attachment. If not functioning properly, always tag DO NOT OPERATE until all problems are corrected.

Charging Backhead with Nitrogen Gas

1. Install pressure gauge onto charging block.
2. Turn handle of charging block clockwise to close the exhaust valve.
3. Connect one end of hose to the nitrogen gas tank.
4. Connect the other end of the hose to the charging block.
5. Remove the plug from the charging valve on the power cell.
6. Install the charging block to the charging valve of the back head. Make sure an O-ring is installed on the charging block.
7. Slowly turn handle of the nitrogen gas tank counter-clockwise to charge the back head. Make sure the exhaust valve of the charging block is fully closed.
8. Shut off the nitrogen gas tank by turning the handle clockwise. Press the switch of the charging block to check the gas pressure inside the back head (the gas pressure shown while pressing the switch is the actual pressure level inside the back head).
9. After checking gas pressure in step 8 (should be 5-10 bar (72 - 145 psi) more than specified pressure level), slowly open the exhaust valve while continuing to press the switch to discharge excess gas until the pressure drops to the specified level.
10. When the gas pressure is set to the specified level, release the switch and open the exhaust valve to discharge gas from the gas hose.
11. Remove charging block from the charging valve.
12. Check for gas leaks using soap bubbles around the charging valve.
13. Install the plug.

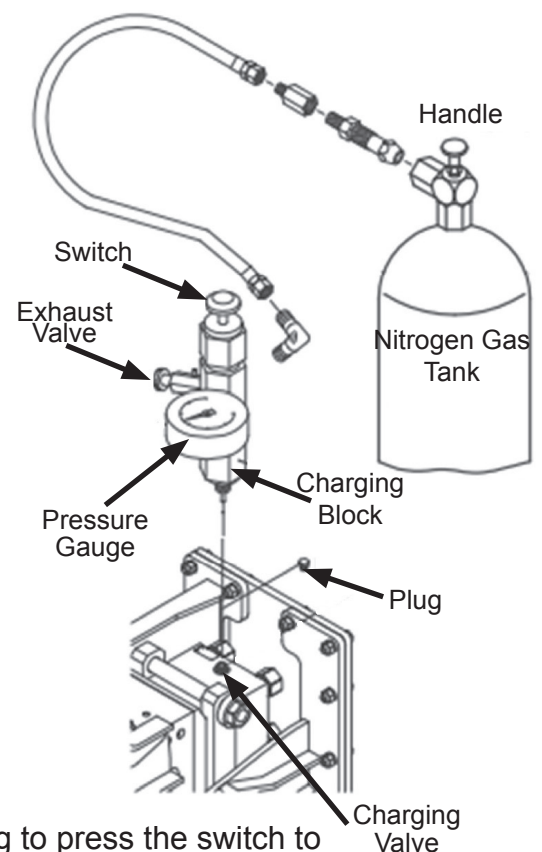

MAINTENANCE & SERVICE

Inspection of Wear Parts

Replace the demolition tool, lower and upper bushings and tool pin when the wear condition reaches the maximum specifications shown below.

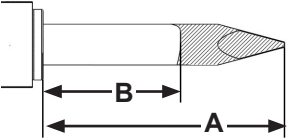
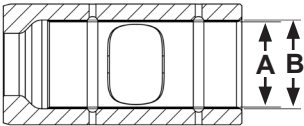
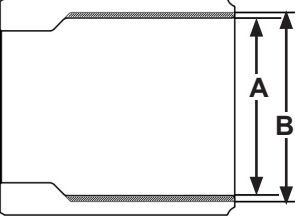
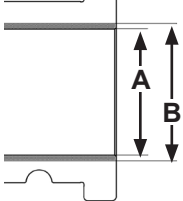
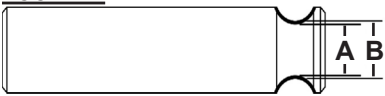
	A (New) inch (mm)				B (Replace) inch (mm)			
	GHB 250	GHB 350	GHB 500	GHB 750	GHB 250	GHB 350	GHB 500	GHB 750
Demolition Tool 	13.5 (343)	14.6 (373)	15 (381)	16.61 (422)	9.0 (230)	9.8 (250)	11 (281)	12.67 (322)
Tool Bushing 	1.5 (40)	2.1 (55)	NA	NA	1.6 (42)	2.2 (57)	NA	NA
Upper Bushing 	NA	NA	2.63 (67)	2.67 (68)	NA	NA	2.72 (69)	2.76 (70)
Lower Bushing 	NA	NA	2.63 (67)	2.67 (68)	NA	NA	2.72 (69)	2.76 (70)
Tool Pin 	0.84 (21.5)	0.86 (22)	1.40 (35.5)	0.78 (20)	0.76 (19.5)	0.78 (20)	1.25 (31.5)	0.62 (16)

MAINTENANCE & SERVICE

Accessory Tools

Tool Description	GHB Model				Notes
	250	350	500	750	
Tool Box (Large Size)	1	1	1	1	
Wrench, 19mm	1	1	-	-	Gas Charging (Back Head)
Wrench, 22mm	1	1	-	-	Gas Charging (Back Head)
Wrench, 24mm	-	-	2	-	Top Plate Bolt
Wrench, 27mm	2	2	-	2	Top Plate Bolt Housing Joint (GHB 250 & 350) Gas Charging (Back Head) GHB 750
Wrench, 30mm	1	1	-	1	In Out Adapter Side Rod (GHB 250) Housing Joint (GHB 500)
Wrench, 36mm	-	1	1	1	Side Rod (GHB 350) In Out Adapter (GHB 500) Housing Joint (Open Housing) GHB 750
	-	-	1	-	Side Rod
Allen Wrench, 8mm	1	-	-	1	Under Water
Hammer Wrench, 41mm	-	-	-	1	Side Rod
T-Wrench, 5mm	-	-	1	1	Gas Charging (Back Head)
Pin Bar, 8mm dia.	1	1	1	-	Tool Pin
Pin Bar, 15mm dia.	-	-	1	1	Bushing (Upper and Lower) Tool Pin (GHB 750)
Driver	-	-	-	1	Rubber Plug (Box Housing)
Grease Gun, 500cc	1	1	1	1	







BOLT TORQUE SPECIFICATIONS

General Torque Specification Tables

Use the following charts when determining bolt torque specifications when special torques are not given. Always use grade 5 or better when replacing bolts.

SAE Bolt Torque Specifications

Note: The following torque values are for use with extreme pressure lubricants, plating or hard washer applications. Increase torque 15% when using hardware that is unplated and either dry or lubricated with engine oil.

Bolt Size		SAE Grade 5 Torque				SAE Grade 8 Torque				Bolt head identification marks as per grade. Note: Manufacturing marks will vary.
		Pounds Feet		Newton Meters		Pounds Feet		Newton Meters		
In	mm	UNC	UNF	UNC	UNF	UNC	UNF	UNC	UNF	
1/4	6.35	8	9	11	12	10	13	14	18	Grade 2 
5/16	7.94	14	17	19	23	20	25	27	34	
3/8	9.53	30	36	41	49	38	46	52	62	
7/16	11.11	46	54	62	73	60	71	81	96	
1/2	12.70	68	82	92	111	94	112	127	152	Grade 5 
9/16	14.29	94	112	127	152	136	163	184	221	
5/8	15.88	128	153	174	207	187	224	254	304	
3/4	19.05	230	275	312	373	323	395	438	536	
7/8	22.23	340	408	461	553	510	612	691	830	
1	25.40	493	592	668	803	765	918	1037	1245	Grade 8 
1-1/8	25.58	680	748	922	1014	1088	1224	1475	1660	
1-1/4	31.75	952	1054	1291	1429	1547	1700	2097	2305	
1-3/8	34.93	1241	1428	1683	1936	2023	2312	2743	3135	
1-1/2	38.10	1649	1870	2236	2535	2686	3026	3642	4103	

BOLT TORQUE SPECIFICATIONS

Metric Bolt Torque Specifications

The following torque values are for use with metric hardware that is unplated and either dry or lubricated with engine oil. Reduce torque 15% when using hardware that has extreme pressure lubricants, plating or hard washer applications.

Bolt head identification marks as per grade.



Bolt Size	Grade	Pitch (mm)	Pounds Feet	Newton Meters	Pitch (mm)	Pounds Feet	Newton Meters
M6	5.6	1.0	3.6 - 5.8	4.9 - 7.9	-	-	-
	8.8		5.8 - 0.4	7.9 - 12.7		-	-
	10.9		7.2 - 10	9.8 - 13.6		-	-
M8	5.6	1.25	7.2 - 14	9.8 - 19	1.0	12 - 17	16.3 - 23
	8.8		17 - 22	23 - 29.8		19 - 27	25.7 - 36.6
	10.9		20 - 26	27.1 - 35.2		22 - 31	29.8 - 42
M10	5.6	1.5	20 - 25	27.1 - 33.9	1.25	20 - 29	27.1 - 39.3
	8.8		34 - 40	46.1 - 54.2		35 - 47	47.4 - 63.7
	10.9		38 - 46	51.5 - 62.3		40 - 52	54.2 - 70.5
M12	5.6	1.75	28 - 34	37.9 - 46.1	1.25	34 - 41	42 - 55.6
	8.8		51 - 59	69.1 - 79.9		56 - 68	75.9 - 92.1
	10.9		57 - 66	77.2 - 89.4		62 - 75	84 - 101.6
M14	5.6	2.0	49 - 56	66.4 - 75.9	1.5	52 - 64	70.5 - 86.7
	8.8		81 - 93	109.8 - 126		90 - 106	122 - 143.6
	10.9		96 - 109	130.1 - 147.7		107 - 124	145 - 168
M16	5.6	2.0	67 - 77	90.8 - 104.3	1.5	69 - 83	93.5 - 112.5
	8.8		116 - 130	157.2 - 176.2		120 - 138	162.6 - 187
	10.9		129 - 145	174.8 - 196.5		140 - 158	189.7 - 214.1
M18	5.6	2.0	88 - 100	119.2 - 136	1.5	100 - 117	136 - 158.5
	8.8		150 - 168	203.3 - 227.6		177 - 199	239.8 - 269.6
	10.9		175 - 194	237.1 - 262.9		202 - 231	273.7 - 313
M20	5.6	2.5	108 - 130	146.3 - 176.2	1.5	132 - 150	178.9 - 203.3
	8.8		186 - 205	252 - 277.8		206 - 242	279.1 - 327.9
	10.9		213 - 249	288.6 - 337.4		246 - 289	333.3 - 391.6

SPECIFICATIONS

Breaker Torque

Item	Unit	GHB Model			
		250	350	500	750
Side Rod (A)	lb-ft (Nm)	221 (300)	332 (450)	332 (450)	442 (600)
Housing Bolt / Nut (B)	lb-ft (Nm)	258 (350)	258 (350)	258 (350)	590 (800)
Top Cover Bolt / Nut (C)	lb-ft (Nm)	221 (300)	221 (300)	221 (300)	221 (300)

GHB 250, GHB 350 & GHB 750

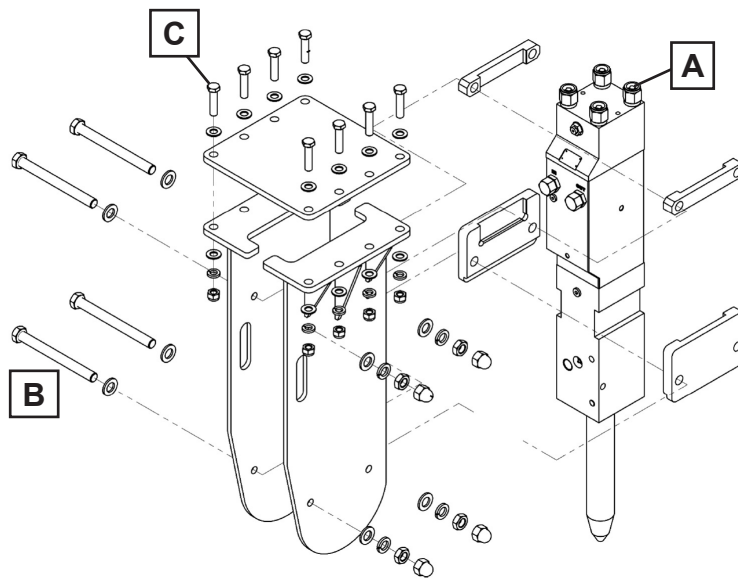

GHB 500

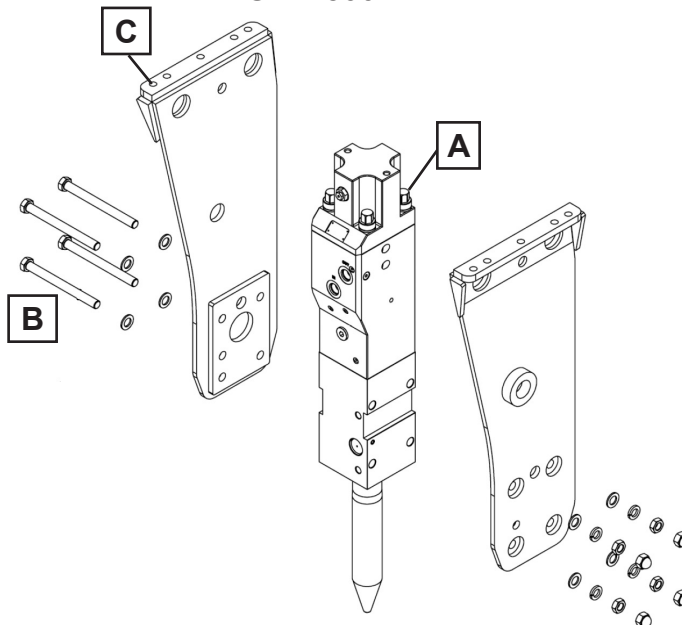

SPECIFICATIONS

General Dimensions

Open Housing

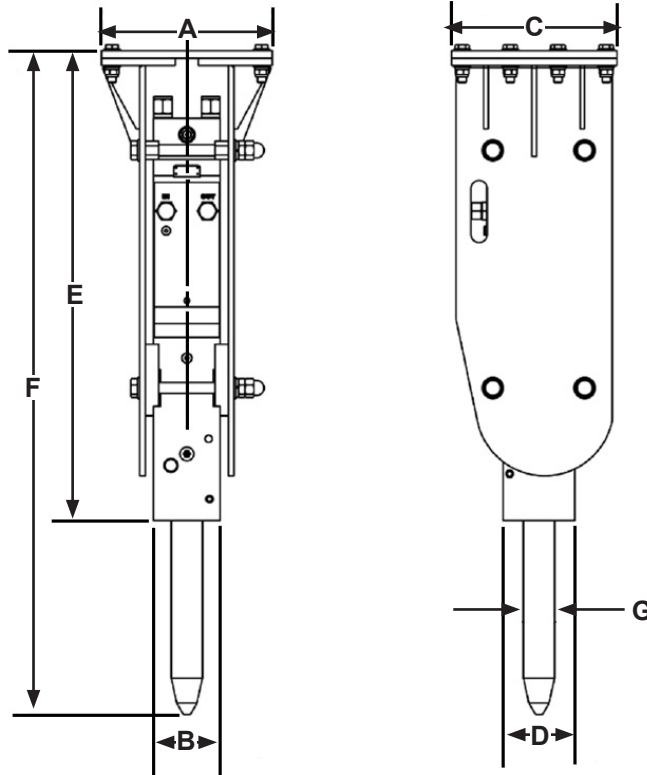

Dimension	Length inch (mm)			
	GHB Model			
	250	350	500	750
A	10.4 (266)	12.9 (330)	12 (305)	12 (305)
B	4.5 (116)	5.1 (130)	6.10 (155)	5.70 (145)
C	11.0 (280)	12.9 (330)	14.69 (373)	14.69 (373)
D	4.7 (120)	5.4 (138)	6.10 (155)	6.14 (156)
E	27.4 (697)	34.1 (867)	38.30 (973)	41.92 (1,065)
F	40.9 (1,040)	48.8 (1,240)	53.74 (1,365)	60.11 (1,527)
G	1.5 (40)	2.1 (55)	2.76 (70)	2.67 (68)

SPECIFICATIONS

General Dimensions

Breaker with Skid Steer Mount

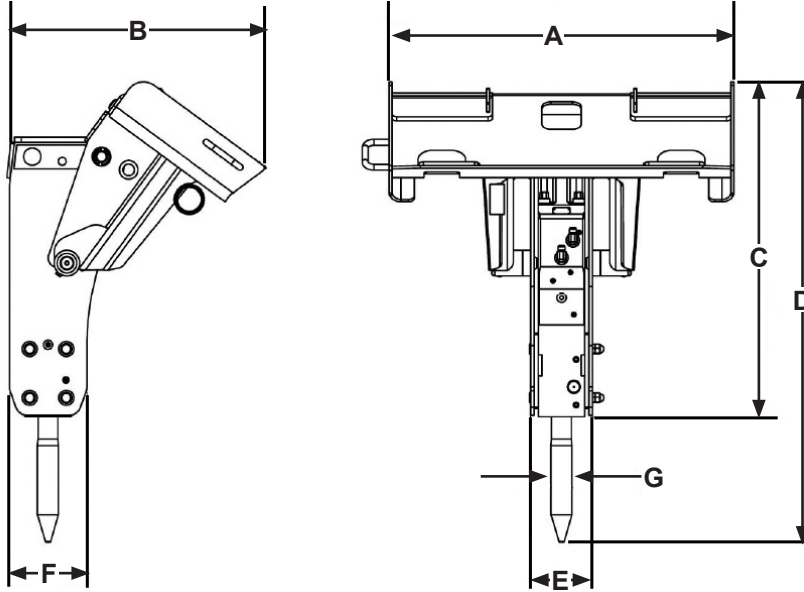

Dimension	Length inch (mm)	
	GHB Model	
	500	750
A	45.31 (1,151)	45.31 (1,151)
B	33.70 (856)	33.70 (856)
C	45.70 (1,161)	49.13 (1,248)
D	62.08 (1,577)	67.32 (1,710)
E	9.89 (251)	9.88 (251)
F	12.68 (322)	13.74 (349)
G	2.76 (70)	2.67 (68)

SPECIFICATIONS

General

Description	Unit	GHB Model			
		250	350	500	750
Working Weight	lbs (kg)	297 (135)	414 (188)	573 (260)	639 (290)
Impact Rate	bpm	700 - 1500	450 - 1150	650 - 1550	600 - 1100
Operating Pressure	psi (bar)	1305 - 1740 (90 - 120)	1305 - 1885 (90 - 130)	1450 - 1030 (100 - 140)	1595 - 2175 (110 - 150)
Relief Pressure	psi (bar)	2320 - 2610 (160 - 180)	2320 - 2610 (160 - 180)	2900 - 3045 (200 - 210)	2900 - 3045 (200 - 210)
Oil Flow	gpm (lpm)	4 - 9.2 (15 - 35)	6.6 - 11.9 (25 - 45)	10 - 21.9 (38 - 83)	11.9 - 21.9 (45 - 83)
Back Pressure	psi (bar)	145 (10)	145 (10)	145 (10)	145 (10)
Tool Diameter	inch (mm)	1.56 (40)	2.15 (55)	2.64 (67)	2.65 (68)
Pressure Line Size	inch (mm)	0.5 (12)	0.5 (12)	0.75 (19)	0.75 (19)
Return Line Size	inch (mm)	0.5 (12)	0.5 (12)	0.75 (19)	0.75 (19)
Excavator Weight	lbs (ton)	2200 - 6600 (1 - 3)	4400 - 9900 (2 - 4.5)	4630 - 7055 (2.1 - 3.2)	4400 - 9900 (2 - 4.5)
Back Head Pressure	psi (bar)	217 (15)	174 (12)	200 (13.8)	160 (11)
Oil Temperature	°F (°C)	-4 ~ +176 (-20 ~ +80)	-4 ~ +176 (-20 ~ +80)	-4 ~ +176 (-20 ~ +80)	-4 ~ +176 (-20 ~ +80)
Hydraulic Oil Viscosity	cSt	1000 - 15	1000 - 15	1000 - 15	1000 - 15

SPECIFICATIONS

Flow Test Procedures

The correct performance of this procedure will verify if the auxiliary circuit of the prime mover is adequate to properly operate the attachment. This procedure is generic in form. It is the end user's responsibility to ensure that this procedure will work with his specific type of equipment. If an adequate flow meter is not available, contact your Genesis dealer for assistance.

TEST PROCEDURE:

1. With the auxiliary circuit (or kit) completely installed connect the flow meter between the tool inlet and outlet hoses.

Note: Always use the hoses that are supplied for the attachment and make sure the machine hydraulic oil is between 90 to 120 °F. this will assure correct readings and adjustments.

2. With the machine setting at the mode that's going to be used to operate the attachment, record the GPM _____.

Locate the correct flow for the attachment in the manual under the specification section. Adjust the machine to the correct GPM.

Note: If possible, always set the machine to the highest GPM output mode. This will prevent the operator from over flowing the attachments.

3. Once the correct GPM flow is achieved fully open the restrictor on the flow meter.
4. With the machine in the attachment mode set in step 2 record the back pressure. At this point the pressure reading on the pressure gauge is the back pressure in the circuit. This pressure must not exceed 200 psi/13.5bar. Excessive back pressure will slow the attachments operation and lead to premature seal failures and over heating.

Record the back pressure _____ psi.

5. Close the restrictor valve on the flow meter until the attachment relief starts to crack or open. The relief valve opens when the flow rate (GPM), indicated on the flow meter begins to decline rapidly. Locate the tools operating system relief pressure in the specification section in the manual. Adjust attachment relief to specification.

Note: The relief valve pressure must be greater than the operating pressure of the attachment and three times the back pressure. Never use the relief valve to control the flow rate in the circuit. Cracking pressure means the loss of 4 or more GPM.

Record the relief cracking pressure _____ psi.

Example:

Operation pressure of a breaker is 2700 psi. Back pressure is 150 psi. A good rule to follow when setting the relief, multiply the back pressure by 3 then add this number to the operation pressure of the attachment.

Operating Pressure 2700 psi

Back pressure 450 psi

Operating pressure of the tool 3150 psi

The relief valve setting must be greater than the estimated operating pressure of the tool. If the setting is lower, damage to the circuit may occur. Excess heat will be generated in the circuit which will damage the attachment and prime mover.

SPECIFICATIONS

Heat Load Test

With the installation kit properly installed and adjusted per the above procedure, conduct the heat load test as follows.

1. Connect the flow meter between the tool inlet and outlet hoses.
2. With the carrier set in the attachment mode, restrict the flow meter until a pressure of 1000 psi is achieved. This pressure must be maintained throughout the heat test.

NOTE: Closing of the restrictor may be required as the temperature increases.

Monitor the oil temperature from the flow meter until no change is noted. Record the time required for oil to stabilize. Record the surrounding temperature (ambient temperature). Record the time required to stabilize _____ minutes.

Record the stabilized oil temperature _____ °F.

Troubleshooting

If adequate pump flow is available from the prime mover pump(s) but it is not getting to the attachment, consult your service representative and review the following:

1. Attachment valve(s) are not actuating. Check all electrical connections that are part of attachment kit.
2. Ensure proper voltage to the valve(s).
3. Ensure the REG port of the valve is not blocked.
4. Check that the prime mover's main relief is set to the manufacturer's recommendation and that this value is equal or greater than the attachment circuit relief.
5. If the valve will not turn off, check the drain (tank) line of valve to ensure the pressure is 50 psi or less.

TROUBLE-SHOOTING GUIDE

Problem	Possible Cause	Possible Solution
Hammer does not start	Pressure and return lines swapped Stop valves closed Gas pressure in back head too high Operating valve jammed Poor performance of hydraulic pump	Check hydraulic line connections Check valves and open if needed Check pressure and adjust if needed Check that operating valve is moving smoothly Check pump and contact prime mover manufacturer if needed
Low impact force	Gas pressure in back head too low Relief pressure setting too low Poor performance of hydraulic pump	Check pressure and recharge as needed Check pressure and adjust as needed Check pump and contact prime mover manufacturer if needed
Slow Operation	Loose connection Oil Leak Stop valves partially closed Gas pressure in back head is too high	Check connection fittings and tighten if needed Check for damaged seals and replace if needed Check valves and open fully if needed Check pressure and adjust if needed
Irregular blow after normal operation	Oil temperature too high Poor performance of hydraulic pump Clearance between demolition tool and tool bushings too large Wear on top of demolition tool Debris in operating valve Seizure of piston and cylinder	Check oil level and top off if needed. Check cooler of the prime mover Check pump and contact prime mover manufacturer if needed Check clearance and replace parts as needed Remove and replace Remove and clean valve Remove and check the breaker

WARRANTY

Claim Procedure

Notify the Genesis Service Department of the potential warranty claim prior to making the repair. Digital pictures are very helpful for diagnosing problems and recommending repairs.

Contact the Genesis Service Department before making alterations, changes or repairs to any component that is going to be considered for warranty. Not doing so will void all Genesis warranty consideration.

The Genesis Service Department will issue an authorization number to track the repair costs, outgoing parts, and/or defective parts returning to the factory.

Replacement parts must be ordered using a purchase order number. Shipping is standard ground. Overnight shipping is available by request, and Genesis will not cover the shipping charge.

When the repair is complete, submit an invoice to the Genesis Service Department within 30 days. Include itemized internal labor reporting, parts lists and invoices for outside contractors. Reference the authorization number on all invoices.

When returning parts for warranty consideration, include a copy of any related Genesis paperwork along with any other necessary documentation to ensure proper processing and credit. The Genesis Service Department will provide the necessary forms.

Your account will be credited when the warranty claim is accepted.

Please direct any questions to the Genesis Service Department: 715-395-5252

PARTS ORDER POLICY AND PROCEDURE

Parts Orders Should Include

- Purchase order number
- Model and serial number of attachment
- Part number and quantity needed
- Shipping and billing address
- Method of shipment or required delivery date

Placing Orders

Orders may be placed by phone, e-mail or fax. To fax an order, use the form on the following page. Contact information is located at the front of this manual.

Part Numbers

Part numbers are listed in a separate Parts Manual or, if included, the Parts section of this manual. Contact the Genesis Parts Department with questions regarding part numbers, availability and pricing.

Shipping

All orders will be shipped best way surface unless an alternate shipping method is requested. Shipping charges are not included in the purchase price of parts.

Invoices

All invoices are due upon receipt. Any accounts with invoices open beyond 60 days are subject to review and may be placed on C.O.D. status without further notice.

Returns

Unused Genesis parts may be returned with proper documentation. Return shipping is the responsibility of the purchaser. Credit will be issued upon return, less a 20% restocking fee. Documentation is required for credit of returned parts. Contact the Genesis Parts Department at 715-395-5252 for a RGA (Return Goods Authorization) number and form.

Return Goods Authorization

All parts returned to Genesis for warranty consideration must be returned with a completed RGA (Return Goods Authorization) provided by the Genesis Parts Department. The form needs to be completed in its entirety, including any additional information requested by the Parts or Service Department. Return freight is the responsibility of the shipper and will be credited upon claim approval. A determination to accept or deny the claim will be made based on the information available to Genesis. Warranty on purchased parts other than wear components is 6 months. There is no warranty period on wear parts or components.



GENESIS®

The Promise of Performance.

CONTACT INFORMATION

Genesis Attachments

1000 Genesis Drive
Superior, WI 54880 USA

Toll Free: 888-SHEAR-IT
(888-743-2748)

Phone: 715.395.5252

E-mail:
info@genesisattachments.com

Europe/Africa/Middle East Genesis GmbH

Teramostrasse 23
87700 Memmingen, Germany

Phone: +49 83 31 9 25 98 0

Fax: +49 83 31 9 25 98 80
genesis-europe.com

E-mail:
info@genesis-europe.com

Asia Pacific Representative Office

24 Upper Serangoon View #12-28
Singapore 534205

Phone: +65 9673 9730

E-mail:
tchoo@genesisattachments.com

Central America & Colombia

Cra 13A #89-38 / Ofi 613
Bogota, Colombia

Phone: +57 1 610 8160 / 795 8747

E-mail:
contact@themsagroup.com

View and download all manuals: genesisattachments.com/manuals
Patents: genesisattachments.com/products/patents

Rev. D - 8-21-19