

Razer X Multi-Jaw Demolition Tool (GRX)

SAFETY & OPERATOR'S MANUAL



CONTACT INFORMATION

Genesis Attachments

1000 Genesis Drive
Superior, WI 54880 USA

Toll Free: 888-SHEAR-IT
(888-743-2748)

Phone: 715.395.5252

E-mail:
info@genesisattachments.com

Europe/Africa/Middle East Genesis GmbH

Teramostrasse 23
87700 Memmingen, Germany

Phone: +49 83 31 9 25 98 0
Fax: +49 83 31 9 25 98 80
genesis-europe.com

E-mail:
info@genesis-europe.com

Asia Pacific Representative Office

24 Upper Serangoon View #12-28
Singapore 534205

Phone: +65 9673 9730

E-mail:
tchoo@genesisattachments.com

Central America & Colombia

Cra 13A #89-38 / Ofi 613
Bogota, Colombia

Phone: +57 1 610 8160 / 795 8747

E-mail:
contact@themsagroup.com

View and download all manuals: genesisattachments.com/manuals
Patents: genesisattachments.com/products/patents

PREFACE

To ensure years of safe, dependable service, only trained and authorized persons should operate and service your Genesis attachment. It is the responsibility of the product's owner to ensure the operator is trained in the safe operation of the product and has available this manual for review. It is the responsibility of the operator and maintenance personnel to read, fully understand and follow all operational and safety-related instructions in this manual. The attachment should not be operated until you have read and fully understand these instructions. Always use good safety practices to protect yourself and those around you.

Important

This operator's manual must accompany the attachment at all times and be readily available to the operator.

Manual Replacement

Should this manual become damaged or lost or if additional copies are required, immediately contact any authorized Genesis dealer or the Genesis Service Department at 888-743-2748 or 715-395-5252 for a replacement.

Registration Form

The Warranty Registration Form must be filled out by the dealer or customer and returned to Genesis indicating the date the attachment went into service.

Possible Variations

Genesis cannot anticipate every possible circumstance that might involve a potential hazard as the owner's requirements and equipment may vary. Therefore, the warnings in this publication and on the product may not be all-inclusive, and you must satisfy yourself that the procedure, application, work method or operating technique is safe for you and others before operating.

Public Notice

Genesis reserves the right to make changes and improvements to its products and technical literature at any time without public notice or obligation. Genesis also reserves the right to discontinue manufacturing any product at its discretion at any time.

Warranty

All work or repairs to be considered for warranty reimbursement must be pre-authorized by the Genesis Service Department. Any alterations, modifications or repairs performed before authorization by the Genesis Service Department will render all warranty reimbursement consideration null and void without exception. See page 61 for Warranty Claim Procedures.

Improper operation or improperly performed maintenance may render any warranty null and void.

TABLE OF CONTENTS

CONTACT INFORMATION	2
PREFACE	3
Important	3
Manual Replacement	3
Registration Form	3
Possible Variations	3
Public Notice	3
Warranty	3
SAFETY STATEMENTS	7
OPERATIONAL SAFETY	8
Read Manual Before Operating or Maintaining the Attachment	8
Personal Protection	8
Know Your Equipment	8
Before Operating	8
Check the Equipment	9
Stability	9
Know the Work Area	10
Starting Procedure	10
Place the Load Safely	10
Safely Operate Equipment	11
Transporting the Attachment	12
Equipment Condition	12
Working Overhead	12
Power Lines	12
Use Care with Hydraulic Fluid Pressure	13
Prioritized Oil Flow	14
Emergency Situations	14
Unsafe Conditions	14
Crystalline Silica Dust	14
Prop. 65 Warning for California Residents	14
Process Material Safely	15
Lift the Load Safely	15
Place the Load Safely	15
MAINTENANCE/TRANSPORT LOCK BOLTS	16
ROTATION LOCK	17
ATTACHMENT INSTALLATION	18
Dual-Pump Flow	18
ROTATOR INSTALLATION	20
Case Drain Line	20
Foot Switch Installation	20
Rotation Circuit - Gear Pump Type	21
Rotation Circuit - Auxiliary Valve on Machine	22
ELECTRICAL INSTALLATION	23
HYDRAULIC START-UP	24
Start-up Procedure	24
JAW SET CHANGE-OVER	25

TABLE OF CONTENTS

MAINTENANCE SAFETY	27
MAINTENANCE SCHEDULE	29
Four-Hour Checklist.....	29
Eight-Hour Checklist.....	30
Long-term Maintenance.....	30
LUBRICATION POINTS	31
BOLT TORQUE SPECS	32
SHEAR JAW SET MAINTENANCE	33
Blade Bolts.....	33
PIERCING BLADES	34
Replacement.....	36
GUIDE BLADES	37
Shimming.....	37
Rotation.....	38
Replacement.....	38
Adjustment Plates.....	38
PRIMARY AND SECONDARY BLADES	39
Removal.....	39
Adjustment Plates.....	40
Rotation.....	40
Blade Gap.....	41
Blade Gap Measuring Procedure.....	41
Shimming.....	41
RAZOR BLADE	42
CRACKER & PULVERIZER JAW SET MAINTENANCE	43
Pulverizing Teeth.....	43
Concrete Cracking Tips.....	44
Cutting Blades.....	45
Blade Removal.....	45
Hard-Surfacing Teeth.....	45
GENERAL WELDING GUIDELINES	46
Welding Ground Clamp.....	46
Welding Rules.....	46
HARD-SURFACING	47
SHEAR JAW BUILD-UP	48
SHEAR JAW HARD-SURFACING PATTERNS	49
CRACKER JAW WELDING MAINTENANCE	50
Hard-Surfacing Patterns.....	50
HYDRAULIC/ROTATION MAINTENANCE	51
Hydraulic Requirements.....	51
Rotation Valve Input.....	51
Rotation Valve Settings.....	51
GenFlow Regeneration Valve.....	52
Regeneration Valve Adjustment.....	52

TABLE OF CONTENTS

GENFLOW REGENERATION VALVE - HOW IT WORKS	53
GENFLOW REGENERATION VALVE	54
GRX 295.....	54
GRX 395.....	54
SLEWING RING MAINTENANCE	55
ROTATION CIRCUIT	56
Auxiliary Valve Rotation.....	56
Gear Pump Rotation.....	56
TROUBLE-SHOOTING GUIDE	58
Attachment.....	58
Rotator.....	59
Lock-Pin.....	60
WARRANTY	61
Claim Procedure.....	61
Blade Warranty.....	61
PARTS ORDER POLICY AND PROCEDURE	62
Parts Orders Should Include.....	62
Placing Orders.....	62
Part Numbers.....	62
Shipping.....	62
Invoices.....	62
Returns.....	62
Warranty Returns.....	62
PARTS ORDER FORM	63
CONTACT INFORMATION	64

NOTICE

For bolt torque specs, see the Genesis Fastener Manual.
genesisattachments.com/manuals

SAFETY STATEMENTS



This symbol by itself or used with a safety signal word throughout this manual is used to call attention to instructions involving your personal safety or the safety of others. Failure to follow these instructions can result in injury or death.



DANGER

This statement is used where serious injury or death will result if the instructions are not followed properly.



WARNING

This statement is used where serious injury or death could result if the instructions are not followed properly.



CAUTION

This statement is used where minor or moderate injury could result if the instructions are not followed properly.

NOTICE

This statement is used where property damage could result if the instructions are not followed properly.

OPERATIONAL SAFETY

Read Manual Before Operating or Maintaining the Attachment



Read this manual before attempting to operate the attachment. This operator's manual should be regarded as part of the attachment. For proper installation, operation and maintenance of the attachment, operators and maintenance personnel must read this manual.



WARNING

Serious injury or death could result if appropriate protective clothing and safety devices are not used.

Personal Protection

Use protective clothing and safety devices appropriate for the working conditions. These may include but are not limited to:

- ✓ Hard hat
- ✓ Safety glasses, goggles or face shield
- ✓ Hearing protection
- ✓ Safety shoes
- ✓ Heavy gloves
- ✓ Reflective clothing
- ✓ Respirator or filter mask



Safety matters

Know Your Equipment



Know your attachment's capabilities, dimensions and functions before operating. Inspect your attachment before operating and never operate an attachment that is not in proper working order. Remove and replace any damaged or worn parts.

Before Operating

- ✓ Warn all others in the area that you are about to start operation.
- ✓ Perform the Check the Equipment steps outlined in this manual.
- ✓ Check underneath and around the machine. Make sure all personnel and equipment are clear from the area of operation and equipment movement. Check clearances in all directions, including overhead.
- ✓ Be properly seated in the operator's seat.
- ✓ Do not attempt to operate until you have read and fully understand this manual and the OEM manual for the carrier.

OPERATIONAL SAFETY

Check the Equipment

Before use, check the equipment to ensure it is in good operating condition.

Check the following:

- ✓ Grease fittings. Pump grease at all fitting locations, see page 31.
- ✓ Hydraulic fluid level. Add hydraulic fluid as required.
- ✓ Hydraulic hoses and hose connections for wear or leaks. Repair or replace any damaged hoses or connections.
- ✓ All control levers for proper operation.
- ✓ Rotation bearing. Visually check for loose or damaged bolts. If repair is required, refer to qualified personnel.
- ✓ Grease rotation bearing and pinion gear.
- ✓ Check for loose or missing pin retaining bolts.
- ✓ Check cylinders for dents (barrel) or dings (rod).



**GOOD
CONDITION**



WARNING

Serious injury or death could result if warnings or instructions regarding carrier stability and the work area are not followed properly.

Stability

Your Genesis attachment is sized for carrier stability. However, improper operation, faulty maintenance or unauthorized modifications may cause instability.

- ✓ Know the working ranges and capacities of the carrier to avoid tipping.
- ✓ Use the recommended carrier counter weight.

The following conditions affect stability:

- Ground conditions
- Grade
- Weight of attachment
- Contents of attachment
- Operator judgement



For greater stability, knuckle the attachment to bring the load closer to the center of rotation (center of gravity) while lifting. Use extra caution during reaching to avoid tipping.

OPERATIONAL SAFETY

Know the Work Area

Check clearances in the work area. Keep all bystanders at a safe distance. Do not work under obstacles. Always check your location for overhead and buried power lines or other utilities before operation.

Check ground conditions. Avoid unstable or slippery areas. Position the carrier on firm level ground. If level ground is not possible, position the carrier to use the attachment to the front or back of the carrier. Avoid working over the side of the carrier.

To reduce the risk of tipping and slipping, never park on a grade exceeding 10% (one-foot rise over the span of a ten-foot run).

Starting Procedure

Before operating, walk completely around the equipment to make certain no one is under it, on it or close to it. Keep all bystanders at least 75 feet away from the area of operation and equipment movement. Let all other workers and bystanders know you are preparing to start. DO NOT operate until everyone is clear.

Always be properly seated in the operator's seat before operating any carrier controls.

To start:

- ✓ Make sure all controls are in the center (neutral) position.
- ✓ Be properly seated.
- ✓ Slowly operate all functions to check for proper operation and to bleed air from the hydraulic system.

To shut down:

- ✓ Return your Genesis attachment to a rest position on the ground.
- ✓ Shut off the carrier engine.
- ✓ Work controls in all directions to relieve hydraulic pressure, per excavator manufacturer's instructions.



WARNING

Serious injury or death could result if warnings or instructions regarding safe operation are not followed properly.

Place the Load Safely

Do not move the attachment, or anything held in the jaws, over people, equipment or buildings. Do not throw or drop the contents. Operate the controls smoothly and gradually.

OPERATIONAL SAFETY

Safely Operate Equipment

Do not operate equipment until you are trained by a qualified operator in its use and capabilities.

See your carrier's manual for these instructions.

- ✓ Operate only from the operator's seat. Check the seat belt daily and replace if frayed or damaged.
- ✓ Do not operate this or any other equipment under the influence of drugs or alcohol. If you are taking prescription medication or over-the-counter drugs ask your medical provider whether you can safely operate equipment.
- ✓ Never leave equipment unattended with the engine running or with the attachment in a raised position. Apply the brakes before exiting the equipment.
- ✓ Do not exceed the lifting capacity of your carrier.
- ✓ Avoid conditions that can lead to tipping. The carrier can tip when operated on hills, ridges, banks and slopes. Avoid operating across a slope which could cause the carrier to overturn.
- ✓ Reduce speed when driving over rough terrain, on a slope, or when turning to avoid overturning the carrier.
- ✓ Never use the attachment as a work platform or personnel carrier.
- ✓ Keep all step plates, grab bars, pedals and controls free of dirt, grease, debris and oil.
- ✓ Never allow anyone to be around the equipment when it is operating.
- ✓ Do not operate poorly maintained or otherwise faulty equipment. Inform the proper authority and DO NOT resume operation until the problem has been fixed.
- ✓ Do not alter or remove any safety features.
- ✓ Know your work site safety rules as well as traffic rules and flow. When in doubt on any safety issue, contact your supervisor or safety coordinator for an explanation.
- ✓ A heavy load can cause equipment instability. Use extreme care during travel. Slow down on turns and watch out for bumps. The equipment may need additional counter-weights to counterbalance the weight of the attachment.



OPERATIONAL SAFETY

Transporting the Attachment

- ✓ Travel only with the attachment in a safe transport position to prevent uncontrolled movement. Drive slowly over rough ground and on slopes.
- ✓ When driving on public roads use safety lights, reflectors, Slow Moving Vehicle signs, etc., to prevent accidents. Check local government regulations that may affect you.
- ✓ Do not drive close to ditches, excavations, etc., as cave-in could result.
- ✓ Do not smoke when refueling the prime mover. Allow room in the fuel tank for expansion. Wipe up any spilled fuel. Secure cap tightly when done.

Equipment Condition

Never operate poorly maintained equipment. When maintenance is required, repair or replace parts immediately.



WARNING

Serious injury or death could result if warnings or instructions regarding working overhead are not followed properly.

Working Overhead

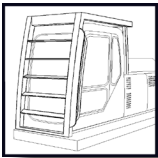

Avoid handling material overhead whenever possible. Safety glass and wire mesh cab guarding must be installed to protect the operator from flying debris that may be created during handling. Falling Object Protection Structures, or FOPS, are necessary for any application where material is to be handled overhead.



DANGER

Serious injury or death will result if warnings or instructions regarding power lines are not followed properly.

Power Lines

Do not operate the machine near energized power lines. All local, state/provincial and federal regulations must be met before approaching power lines, overhead or underground cables, or power sources of any kind with any part of the carrier or attachment. Always contact the appropriate utility when operating near power lines. The lines should be moved, insulated, disconnected or de-energized and grounded before operating in the area.



Current in high voltage lines may arc some distance from the wire to a nearby ground. Keep all parts of the machine at least 50 feet (16m) away from power lines.

OPERATIONAL SAFETY



WARNING

Serious injury or death could result if warnings or instructions regarding hydraulic fluid pressure are not followed properly.

Use Care with Hydraulic Fluid Pressure

Hydraulic fluid under pressure can penetrate the skin and cause serious injury or death. Hydraulic leaks under pressure may not be visible.

- ✓ Keep unprotected body parts, such as face, eyes and arms as far away as possible from a suspected leak. Flesh injected with hydraulic fluid may develop gangrene or other permanent injuries.
- ✓ If injured by injected fluid see a doctor immediately.
- ✓ Wear safety glasses and protective clothing and use a piece of cardboard or wood when searching for hydraulic leaks.

Do Not Use Your Hands!
See illustration below.

- ✓ Hydraulic oil becomes hot during operation. Do not let hydraulic oil or components contact skin, as it could cause severe burns. Allow hydraulic components to cool before working on them. Use appropriate protective clothing and safety equipment. If burned, seek immediate medical attention.

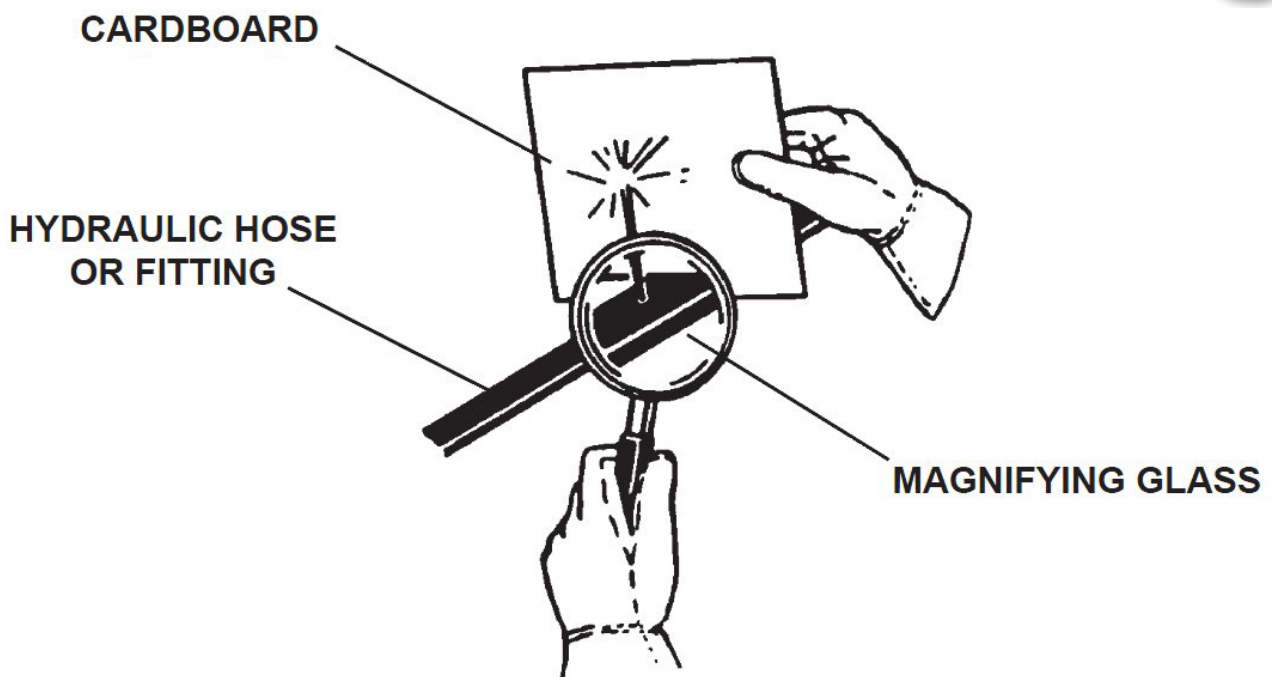

OPERATIONAL SAFETY

Prioritized Oil Flow

Equipment operators must ensure there is prioritized oil flow to the main valves in overhead operations or high reach conditions.

Emergency Situations

Always be prepared for emergencies. Make sure a fire extinguisher is available. Be familiar with its operation. Make sure to inspect and service the fire extinguisher regularly. Make sure a first aid kit is readily available.



Unsafe Conditions

Do not operate if an unsafe condition exists. Stop operation immediately, shut down the machine and report the unsafe condition to the proper authority. Equipment operation and maintenance practices directly affect your safety and the safety of those around you. Always use common sense while operating and be alert to unsafe conditions.

Crystalline Silica Dust

It is recommended to use dust suppression, dust collection and if necessary, personal protective equipment during the operation of any attachment that may cause high levels of dust.



DANGER

Exposure to respirable crystalline silica dust along with other hazardous dusts may cause serious or fatal respiratory disease.

IMPORTANT: Concrete and masonry products contain silica sand. Quartz, which is a form of silica and the most common mineral in the Earth's crust, is associated with many types of rock.

Some activities that may have silica dust present in the air include demolition, sweeping, loading, sawing, hammering, drilling or planing of rock, concrete or masonry.

It is recommended to use dust suppression (such as water) or dust collection (such as a vacuum) along with personal protective equipment if necessary during the operation of any attachment that may cause high levels of silica dust.



Prop. 65 Warning for California Residents



WARNING

This product may contain chemicals known to the State of California to cause cancer, birth defects, or other reproductive harm. For more information visit: P65Warnings.ca.gov

OPERATIONAL SAFETY



WARNING

Using your Genesis attachment in unauthorized applications may create an unsafe situation and will void the warranty.

Process Material Safely

- Do not process hardened steel material such as tool steel, railroad rail, axles, springs, machined parts or high-strength material. Hardened/high-strength material breaks, rather than shears, which may cause flying debris. It will also cause damaging decompression spikes to your Genesis attachment and base carrier hydraulic systems.
- Do not operate any functions of the carrier while cutting or crushing with your attachment, including boom and drive functions.
- Do not pull down structures with your Genesis attachment. Doing so may cause falling debris or material to break free and exceed the capacities of the carrier, causing a tipping hazard and rotation component failures.
- Do not use rotation to pry or break material. Doing so exerts high back-driving forces and spikes to the rotation circuit components that cannot be cushioned hydraulically. It may also cause motor and gearbox failures. The rotator should only be used for positioning an attachment.
- Do not process pressurized containers unless the main valve has been removed and you are absolutely certain the container is empty.
- Do not process spring loaded brake chambers and automotive struts as the release of compressed springs is extremely dangerous. Nothing made of spring material or containing springs should be processed.

Lift the Load Safely

- The hydraulic system has been preset and tested by your dealer. Do not alter hydraulic settings without consulting an authorized Genesis dealer or the Genesis Service Department. Doing so will void the warranty and may cause structural damage, accidents or tipping.
- Make sure the load is held securely in the jaws. Do not move a loaded attachment if load is loose or dangling. Make sure the load is pinched between the jaws – never cradle a load.
- For greater stability, knuckle the attachment to bring the load closer to the center of rotation (center of gravity) while lifting. Use extra caution during reaching to avoid tipping.

Place the Load Safely

- Do not move the attachment, or anything held in the jaws, over people, equipment or buildings. Place the load gently. Do not throw or drop the contents.
- Operate the controls smoothly and gradually. Jerky controls are hazardous and may cause damage to the carrier.
- Avoid fire hazards. Keep the area clean. Remove all flammable materials from the area during any welding or heating process. Have a fire extinguisher nearby and know how to use it.
- Never substitute pins or bolts. Use factory supplied pins. Replace all bolts with the same size and grade. Failure to do so may cause serious injury or death.
- Use your Genesis attachment only as directed in this manual. Do not use the attachment to lift and move other objects. Doing so may cause instability and tipping.

MAINTENANCE/TRANSPORT LOCK BOLTS

GRX demolition tools ship from the factory with lock bolts installed in the body and cylinder lock pins as show below.

The lock bolts are to be installed any time the tool is transported or maintenance is performed to prevent inadvertent lock pin movement during these operations.

Remove the lock bolts prior to normal operation.

MAINTENANCE / TRANSPORT LOCK
REMOVE BEFORE OPERATION

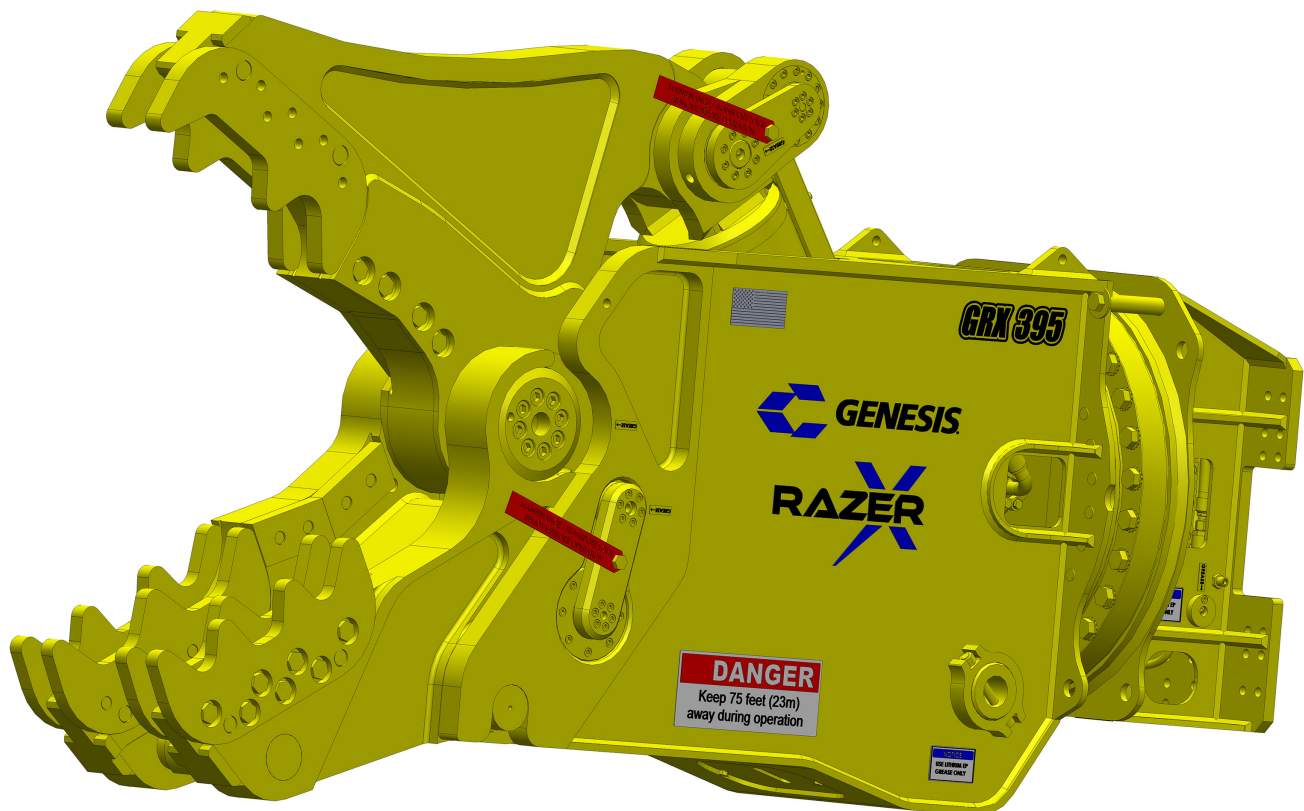

ROTATION LOCK

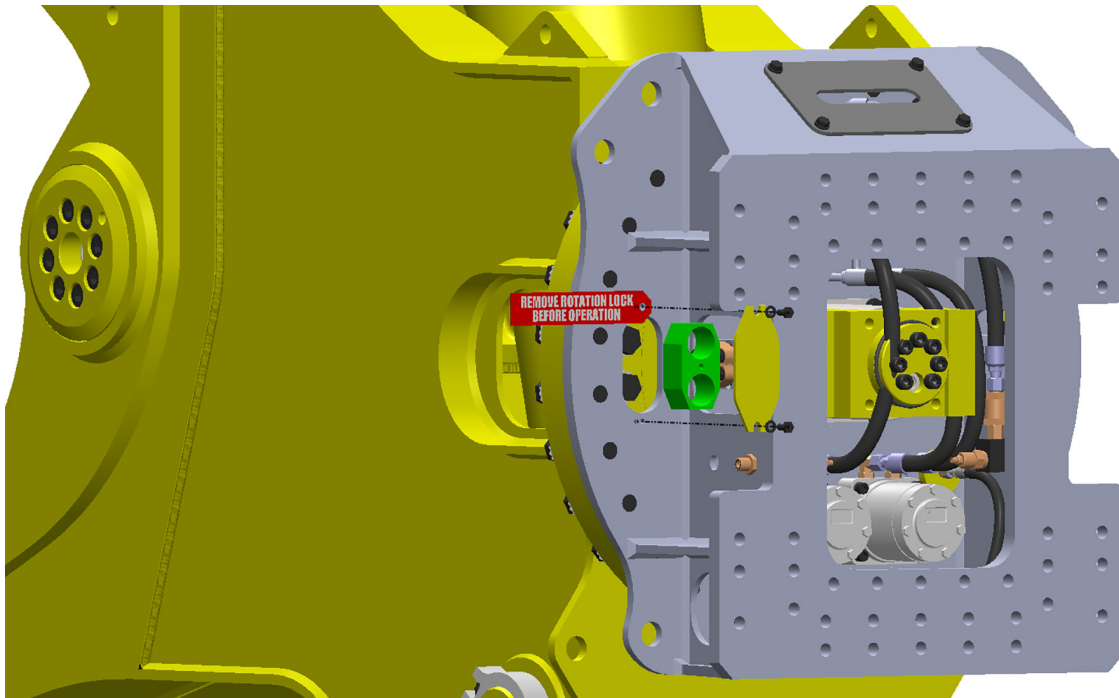

Rotation (transport) locks are installed at the factory to allow the bracket to be shipped with the mounting pins facing upward. This is beneficial to the end user when removing the attachment from the truck and mounting it to the excavator.

Rotation locks MUST be removed before operating the attachment to prevent rotation system damage.

The rotation locks are located inside the small bolt covers for the slewing ring and marked with a red flag labeled “REMOVE ROTATION LOCK BEFORE OPERATION”. The cover bolt can be threaded into the rotation lock for removal.

There are TWO locks in every attachment, one on either side of the bracket. In some cases, one of the port blocks may need to be removed to access the rotation lock. The rotation locks and red flags should be saved for use during future transportation.

ATTACHMENT INSTALLATION

Preparation of the excavator prior to attachment delivery will make installation safer and easier. Contact Genesis or your Genesis dealer for assistance.

Dual-Pump Flow

An excavator typically has two hydraulic pumps that supply oil to its main control valve, which is usually separated into two halves. Combining the flow from both halves of the control valve is called summing, thus achieving dual-pump flow to operate one circuit.

Summing is the preferred method of achieving maximum speed to an attachment. However, interchanging the stick and bucket circuits may also substantially increase speed.

A bucket circuit is usually single-pump flow while a stick circuit is dual-pump flow. At times, adding an auxiliary circuit spool to the stick circuit helps reduce back pressure in the system and speed up jaw open and close.

In certain cases, the bucket and auxiliary circuits can be summated to achieve dual-pump flow, depending on whether the bucket and auxiliary are on separate sides of the main valve and whether the auxiliary circuit can be proportionally controlled by teeing into the bucket pilot control circuit.

The auxiliary circuit must also be capable of proportionally controlling pump initiation on the auxiliary side of the circuit. On many excavators, the auxiliary circuit is controlled by the flow percentage set in the operating system. Because attachments take all the flow the pumps can give them, when this percentage is reached, the pump will instantly turn on or off instead of gradually increasing or decreasing, which can cause sharp, damaging spikes in the hydraulic circuit.

If excavator circuits are electronically controlled, it may be necessary to reduce the spool shift and pump initiation in the excavator software to take spiking out of the circuit when changing attachment cylinder direction from full extend or full retract.

On excavators with full hydraulic spool piloting, install a flow control into the pilot lines between the joystick and spools. The flow control can then be adjusted to slow the pilot oil flow to the spool, which in turn slows how the spool shifts and the pumps stroke up.

ATTACHMENT INSTALLATION



WARNING

Be sure hydraulic pressure is relieved before disconnecting hydraulic fittings. Remove necessary fittings SLOWLY.

The attachment is usually shipped in an upright position. Extreme care must be used when inverting the attachment for installation.

Follow the excavator OEM's removal and safety instructions to remove the bucket or other stick attachments.

Position the attachment upside down on flat, solid ground. Blocking may be required to raise the mounting bracket into proper position.

Track the excavator to the attachment with the jaws facing the operator. Lift the excavator stick over the attachment, carefully positioning the stick tip connection with the attachment mounting main pivot bore. Pin the excavator stick to the attachment.

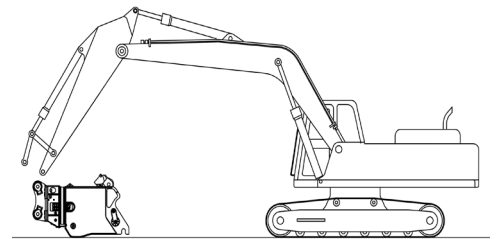

Slowly raise the boom to lift the attachment, allowing the cylinder pivot connection to come within range of the excavator cylinder stroke.

Extend the excavator cylinder until the power link bore lines up with the cylinder pivot connection. Pin the excavator cylinder to the attachment.

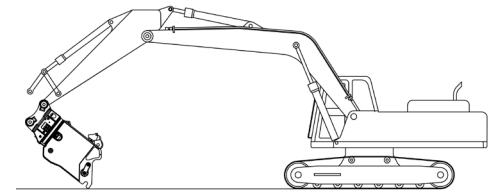

Crowd and extend the attachment, checking closely to make sure there is no interference between the bracket and hard lines. Also check for interference between the cylinder and boom/stick.

Install excavator hydraulic hoses, supply and return, from the stick tip to the attachment manifold blocks. See page 23 for electrical installation.

The stick and bucket circuits are oriented as to rod and bore sides of their respective cylinders. Be sure to connect rod-to-rod and bore-to-bore when connecting a circuit to the attachment. When these are reversed, extra pressure is needed to open the jaw, which pulls down the engine, de-strokes the pumps, increases jaw cycle time, creates high oil temperature and burns more fuel.

The attachment must be vertical before putting oil into it or an air lock in the regen valve may prevent the jaw from opening.

Note: Genesis' standard pin material is Induction Hardened Chrome (IHC), which is to be used for all direct pin 2nd and 3rd member mounting. To avoid risk of pin failure when using a pin grabbing coupler, the standard IHC pins must be replaced with a heat-treated pin material from Genesis.



WARNING

Removing any connecting pin may be hazardous. To remove a connecting pin, position the attachment on the ground and properly support. Particles may fly when a pin is struck. Use a drift pin or mallet when striking pins. Keep all personnel at a safe distance.

ROTATOR INSTALLATION

Case Drain Line

All GRX Demolition Tools require a case drain line be installed, 1/2" line size minimum. The pressure in this line must be below 50 PSI at all times.

Foot Switch Installation

Install the foot switch in the excavator and connect with electrical harness. Consult excavator dealer when using an alternate to the Genesis supplied foot switch.

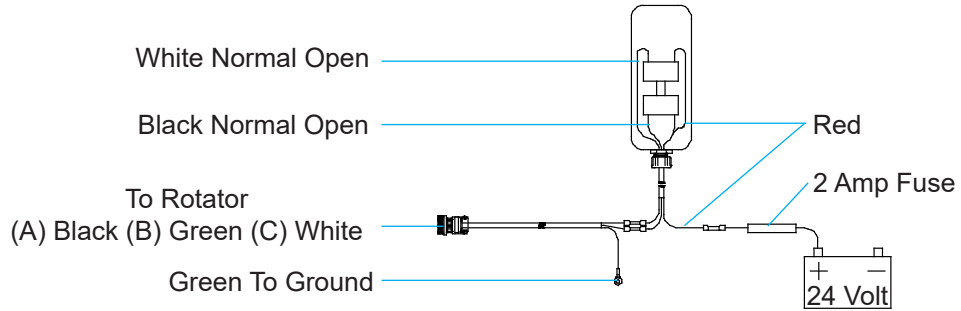

ROTATOR INSTALLATION

Rotation Circuit - Gear Pump Type

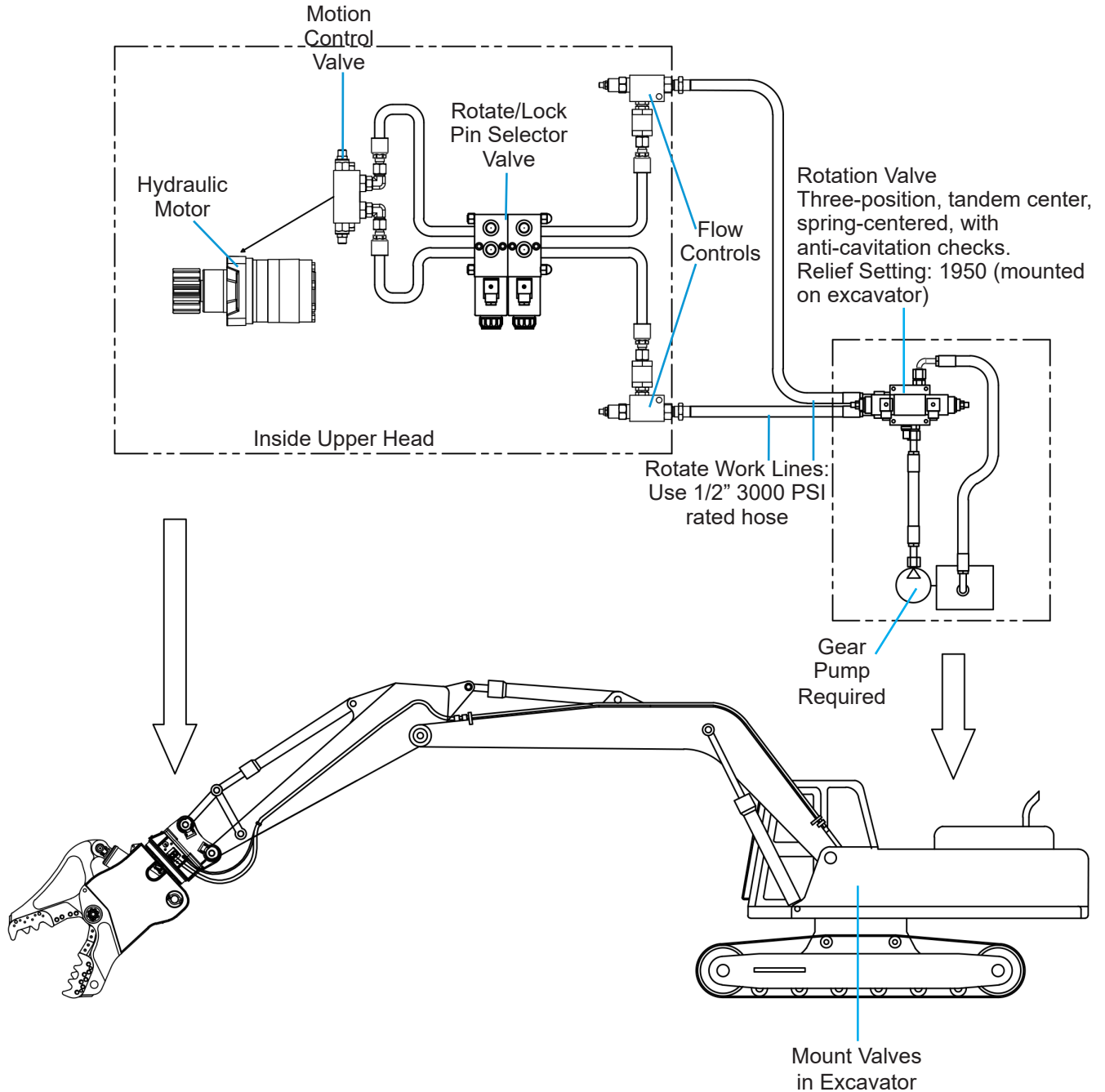

ROTATOR INSTALLATION

Rotation Circuit - Auxiliary Valve on Machine

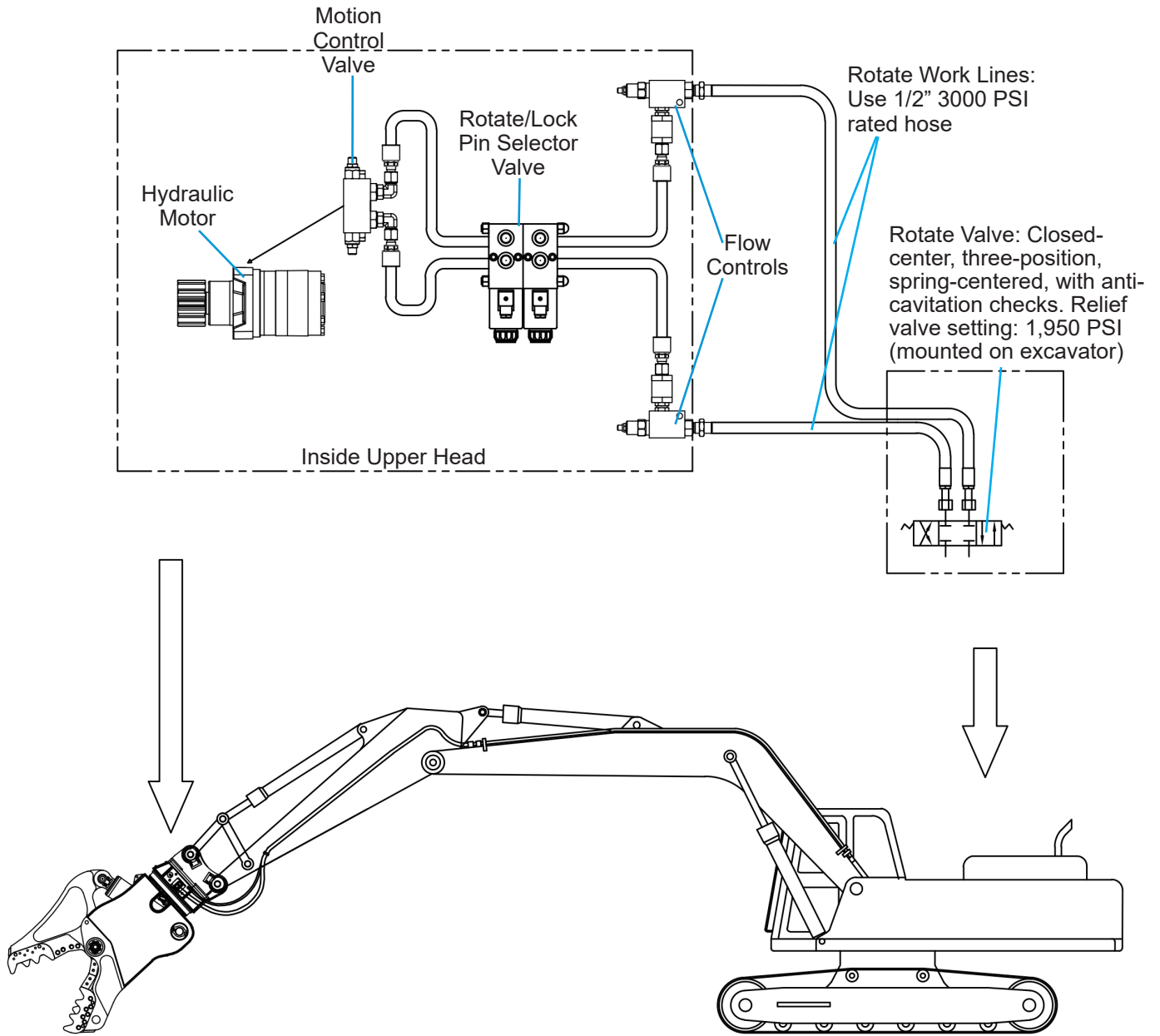

ELECTRICAL INSTALLATION

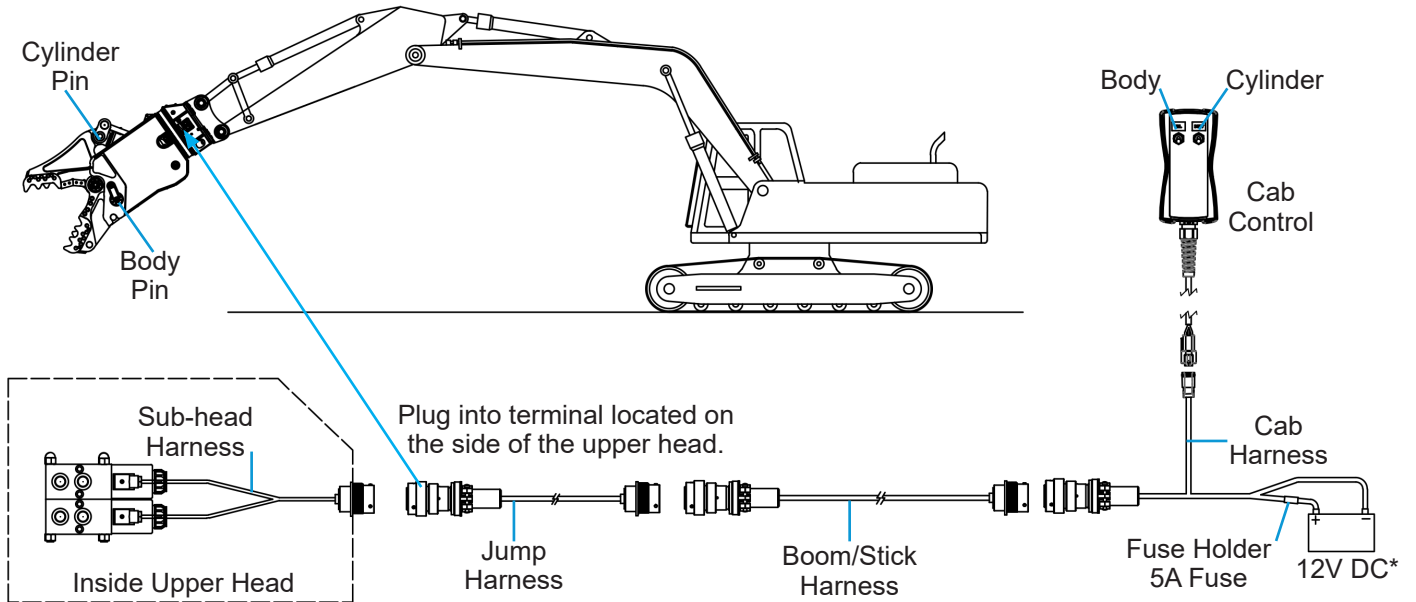

* The GRX 295 requires 24V DC.
 GRX 395 SN395101-395110 requires 12V DC.
 GRX 395 SN395111 and up requires 24V DC.

HYDRAULIC START-UP

Genesis attachments are designed to operate under full excavator pressure or up to 5500 PSI. Due to these high pressures, it is important that air is bled from the attachment cylinders after installation. Failure to follow these procedures could result in cylinder seal damage and/or excavator hydraulic system damage.

Start-up Procedure

- ✓ Check the excavator hydraulic tank for proper fluid level.
- ✓ The excavator oil should be warmed up before hooking up attachment lines in cold weather. If the oil is cold, air from the cylinder will be pushed into the oil tank, causing the oil to foam. This problem takes hours to correct and may cause pump cavitation.
- ✓ Follow the OEM procedures for starting and warming the excavator hydraulic system. Do not operate the attachment circuit during the warm-up period.
- ✓ After the excavator has reached normal operating temperature, set the engine to idle speed.
- ✓ The attachment must be vertical. Do not allow the tank to run low - have someone watch the oil gauge.
- ✓ Slowly fill the bore end of the attachment cylinders to partially close the jaws.

NOTICE

Do not fully extend or retract attachment cylinders with the first cycles.

Slowly fill the rod end of the attachment cylinders to open the jaws. Use partial strokes extending and retracting, slowly working to full strokes.

Stop and check the excavator hydraulic fluid level again to be sure there is still sufficient fluid. Service as required.

Cycle the attachment jaws five or six strokes before increasing to full operating pressure.

JAW SET CHANGE-OVER

GRX jaw set change-over can be fully completed by the operator while staying in the cab, if the carrier is properly and completely wired with all the appropriate wiring harnesses and the cab control box. Basic safety precautions should be used to ensure all ground personnel are clear while making the jaw change.

Change-over procedure:

Close jaw set completely prior to setting it in the stand.

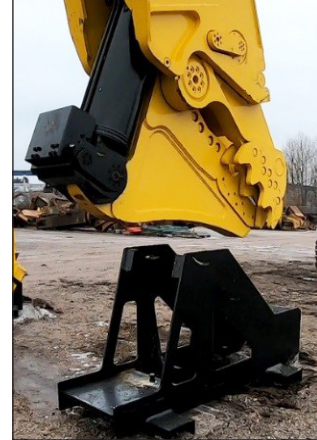

Press and hold CYL switch on the cab control box, actuate the appropriate joystick or foot switch to extend the cylinder pin. Release CYL switch when pin is fully extended.

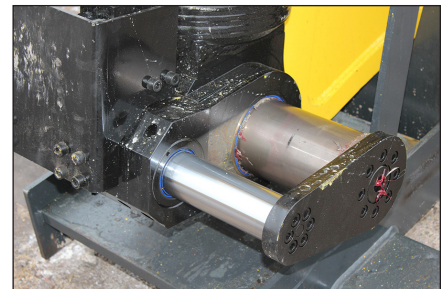

Press and hold BODY switch on the cab control box, actuate the appropriate joystick or foot switch to extend the body pins. Release BODY switch when pins are fully extended.



JAW SET CHANGE-OVER

Articulate the GRX body to disengage the jaw set.

Position the GRX body at the new jaw set.

Articulate the attachment body to engage the new jaw set.

Both left and right trunnion pins must be seated in the body hooks.



When the body is seated against the stop on the jaw set, the body pins can be retracted. Press and hold the BODY switch on the cab control box and actuate the appropriate joystick or foot switch to retract the body pins. Release BODY switch when pins are fully retracted.

Body pins must be retracted completely prior to lifting the jaw set out of the jaw stand.

Lift jaw set out of the jaw stand.

Articulate the GRX Body until the upper jaw and cylinder pin align.

Press and hold CYL switch on cab control box and actuate the appropriate joystick or foot switch to retract the cylinder pin. Some adjustment to the articulation may need to be done to get the Cyl pin position correct to retract the pin. Release the CYL switch when the pin is fully retracted.

Rotate the GRX a full 360 degrees to visually ensure all pins are retracted completely as well as to confirm the valve has reset to the rotate mode.

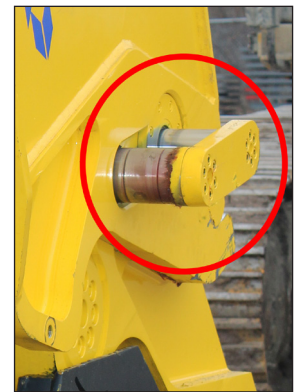

MAINTENANCE SAFETY

Only trained and authorized persons should perform maintenance on the attachment. To be qualified, you must understand the instructions in this manual, have training, and know the safety rules and regulations of the job site.

Do not alter the physical, mechanical or hydraulic operation of the attachment. Doing so may cause a dangerous situation for yourself and those around you and will void the warranty.

Do not attempt repairs you do not understand. If any questions arise regarding a safety or maintenance procedure, contact Genesis or your Genesis dealer.

Read this entire manual. All personnel must understand the maintenance and safety procedures.

Use factory authorized parts. The use of unauthorized parts may compromise safety, performance and durability of the attachment and may void the warranty.

Follow the daily checklist and maintenance schedules in this manual. Extreme conditions may dictate shorter maintenance intervals.

Do not exceed bolt torque specifications. See the Genesis Fastener Manual.

Do not weld on structural components without consulting Genesis. Doing so may cause structural failure and void the warranty.

Do not work on the attachment before ensuring it will not move. Completely lower the boom to the ground or a rest position and relieve hydraulic pressure.

Never operate poorly maintained equipment. When maintenance is required, repair or replace parts immediately.

Do not operate under unsafe conditions. If an unsafe condition arises during operation, immediately shut down the equipment and report the situation to the proper authority.

MAINTENANCE SAFETY

Do not work on any hydraulic lines or components while they are pressurized. Escaping hydraulic fluid can penetrate the skin, causing serious injury or death. Relieve pressure before performing maintenance. Keep hands and body parts away from pin holes and nozzles, which eject fluids under high pressure. Use a piece of cardboard to search for leaks.



If fluid is injected into the skin, seek medical assistance immediately from a doctor familiar with this type of injury.

NOTICE

See “Use Care with Hydraulic Fluid Pressure”, page 13

Hydraulic oil becomes hot during operation. Do not let hydraulic oil or components contact skin, as it could cause severe burns. Allow hydraulic components to cool before working on them. Use protective clothing and safety equipment.



Remove paint before welding or heating. Hazardous fumes/dust can be generated when paint is heated by welding, soldering or using a torch. Do all work outside or in a well ventilated area and dispose of paint and solvent properly.

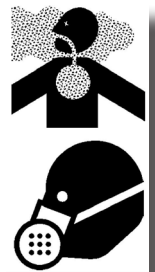

When sanding or grinding paint, avoid breathing the dust. Wear an approved respirator. If you use solvent or paint stripper, remove stripper with soap and water before welding. Remove solvent or paint stripper containers and other flammable materials from area. Allow fumes to disperse at least 15 minutes before welding or heating.

Avoid fire hazards. Keep the area clean. Remove all flammable materials from the area during any welding or heating process. Have a fire extinguisher nearby and know how to use it.



Never substitute pins or bolts. Use factory supplied pins. Replace all bolts with the same size and grade. Failure to do so may cause serious injury or death.

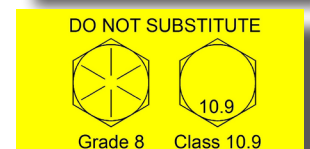

MAINTENANCE SCHEDULE

Performing scheduled maintenance will promote safe, reliable operation of your attachment. Use maintenance procedures described in this manual. If you are not able to safely and competently perform these procedures, have a Genesis dealer perform them.

Extreme operating conditions may require shortened maintenance intervals.

Four-Hour Checklist

Inspect:

- Bolts - check for loose bolts, replace if damaged
- Fittings and hoses for damage or leaks
- Bracket pivot for wear and pin retainers
- Cylinder pivot for wear and pin retainers
- Entire attachment for cracks (visual check)

Grease:

- Bracket pins (two locations)
- Attachment cylinder butt
- Attachment cylinder rod (three locations)
- Main shaft end caps (both sides)
- Grease lock pins, both sides, every 4 hours or at least once per shift on each jaw set while in use

MAINTENANCE SCHEDULE

Eight-Hour Checklist

Perform four-hour checklist plus the following:

Grease:

- Rotation bearing (four locations)
- Rotation head

Shear jaw set (follow this sequence):

- Check blade tolerance
- Check blade edge radius
- Check for loose or damaged bolts, retorquing loose bolts when cool
- Build-up and hard-surface as required

Concrete pulverizer jaw set:

- Check for loose or damaged bolts, retorquing loose bolts when cool
- Build-up and hard-surface as required

Concrete cracker jaw set:

- Check blade edge radius
- Check for loose or damaged bolts, retorquing loose bolts when cool
- Build-up and hard-surface as required

For all jaw sets:

- Ensure jaw set trunions are not damaged.
- Inspect, and clean if necessary, the lock pin bores and upper cylinder bores on all jaw sets not in use and stored in their stands.

Long-term Maintenance

- After the first 80 hours of operation, check all bolts, including slewing ring bolts.
- Replace regeneration valve components every 4000 hours.
- Reseal cylinders every 4000 hours initially and every 3000 hours following.
- Reseal swivel every 4000 hours.

LUBRICATION POINTS



Shut off excavator and disable hydraulics per OEM instructions before greasing.

For normal conditions above 32°F (0°C), use a lithium-based, premium grade 2 extreme-pressure grease. For temperatures below 32°F, use a grade 0 grease.

Do not use grease containing Molybdenum (Moly).

Genesis GLG-2[®] anti-wear, extreme-pressure lithium grease, PN 6302601, is recommended for all temperature conditions.

Grease all fittings every four hours of operation. Grease until extrusion is visible.

After greasing the rotation bearing, rotate the attachment through two full rotations.

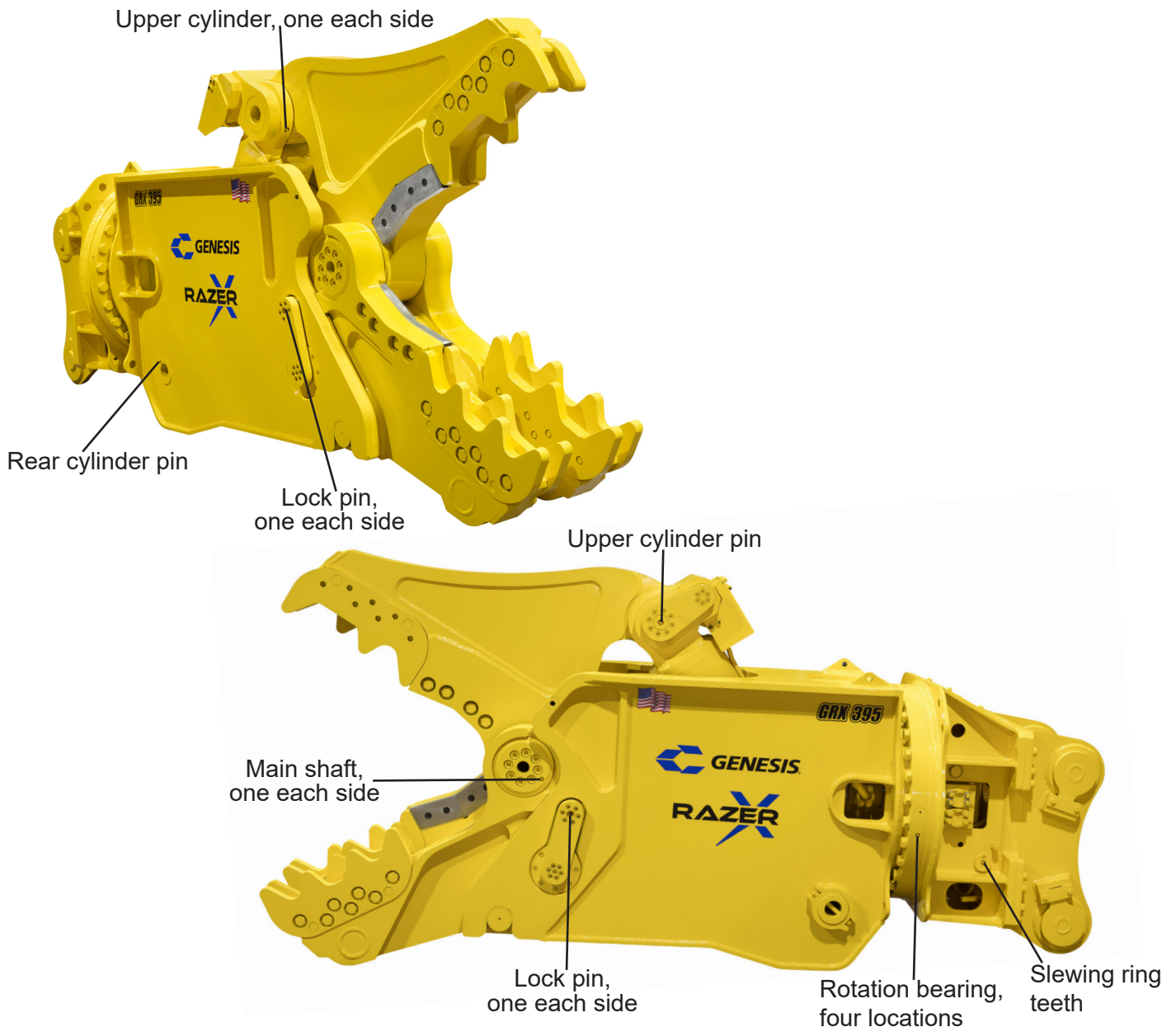

BOLT TORQUE SPECS

**Bolt torque specs and thread treatment procedures can be found in the
Genesis Fastener Manual.**

genesisattachments.com/manuals

SHEAR JAW SET MAINTENANCE

Blade and jaw maintenance greatly affects performance. To maximize cutting performance and optimize the life of replaceable parts, follow this specific sequence of checks, adjustments and maintenance.

1. Piercing Blades - replace when edges are worn.
2. Guide Blades - rotate, shim to tolerance, and replace when worn.
3. Primary and Secondary Blades - rotate; replace when all edges are worn. Shim lower blades to tolerance.
4. Razor Blade - rotate and replace when all edges are worn.
5. Welding Maintenance - perform jaw build-up and hard-surface as needed.

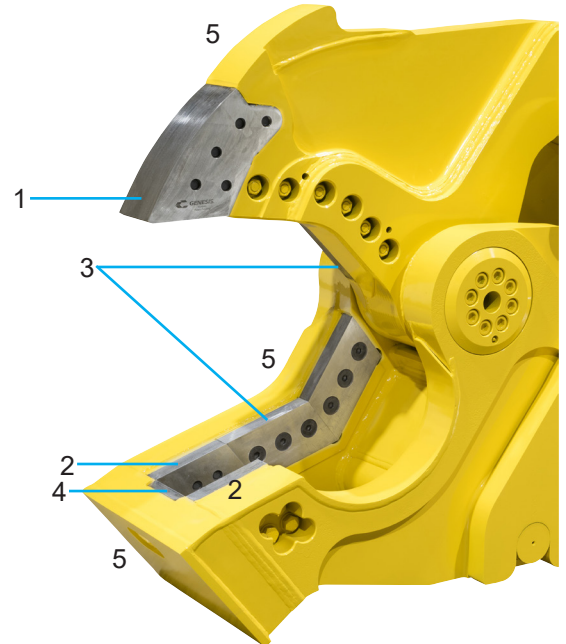

Blade Bolts

Torque blade bolts every eight hours to the specifications listed in the Genesis Fastener Manual torque chart. Check for broken bolts daily and replace them immediately.

PIERCING BLADES

Piercing blade maintenance is crucial to productivity and safe shear operation. An improper blade gap may cause material jamming and/or blade breakage.

Use the following procedure to check for wear.

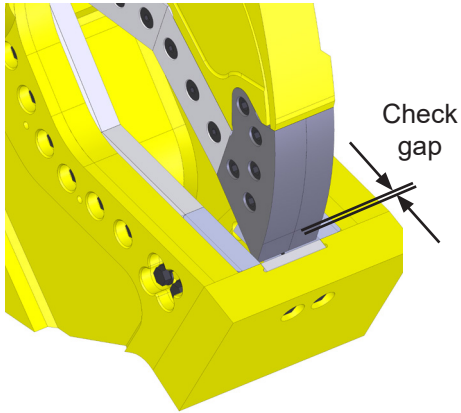

1. Slowly close jaws until the piercing blades are flush with the top edge of the razor blade.
2. Check gap with a tape measure. Acceptable gap is 5/8".
3. Check the condition of the piercing blades with a straight edge or square.
4. Check the profile along the blades.

5. Badly worn blades must be replaced. However, slightly worn blades may be squared up with a grinder and a square. This may be repeated until a maximum of 1/2" of material is removed from the lower piercing edge.

6. Typical use requires blade replacement at approximately 200 hours; heavy piercing requires replacement at approximately 40 hours. These are general guidelines only. Replace blades based on wear not hours of operation.

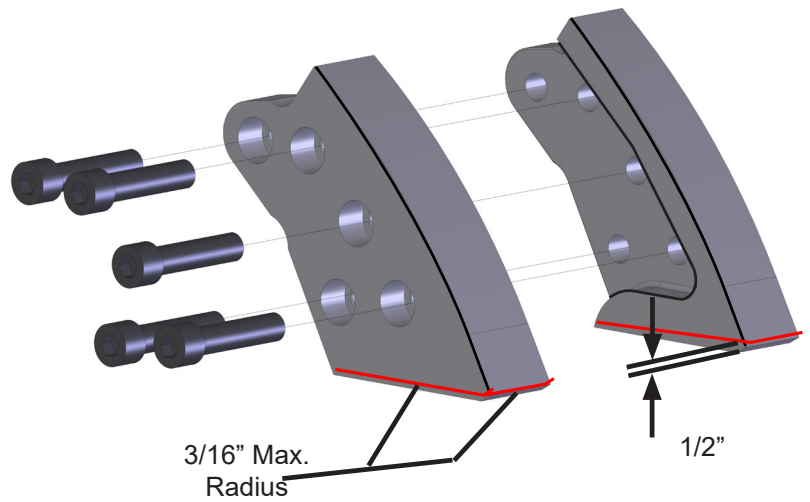

7. Width of blades, top to bottom, may taper 0.060" (2 mm) total. Bottom edges may be worn to a maximum radius of 3/16".

PIERCING BLADES

Piercing blades must fit tightly in some areas while having clearance in others. Piercing blades are made from the same material as the cutting blades to withstand the friction caused by piercing hard materials.

Areas **Highlighted in Blue** require contact fit to the upper jaw and tang to prevent shattering.

Areas **Highlighted in Red** require an air gap, and blades may occasionally need to be ground down to provide clearance.

Piercing blade contact with the clearance areas (**red**) can cause abnormal stress in the blade. This may cause the piercing and/or guide blades to crack, break or shatter.

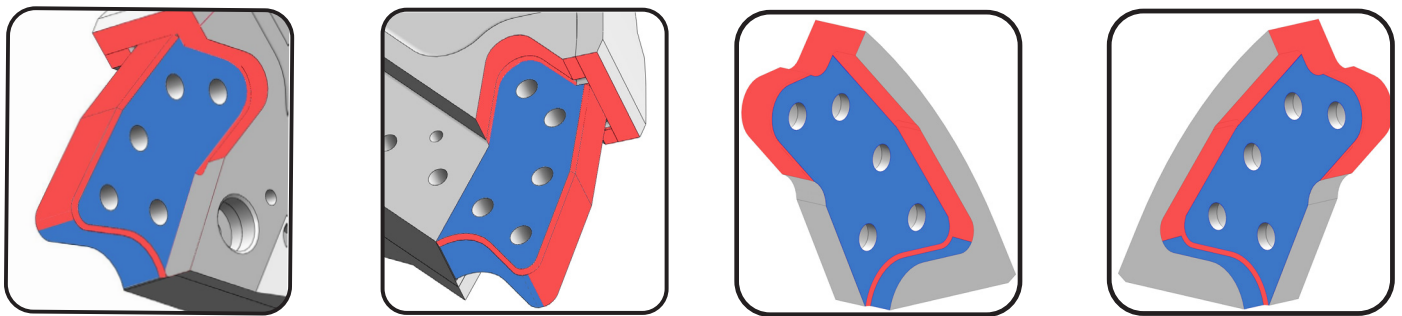

When necessary, build up the front lower edge of the tang (areas **highlighted in yellow**), following the procedures given in this manual. After welding, surfaces should be squared with a grinder and finished with a file and a machinist's straight edge.

It is critical that the piercing blade pocket and tang surfaces are straight and true, without dings, deformations, high or low spots, or areas that are worn away.

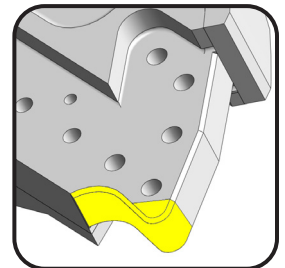

Piercing blade bolts must not make hard contact with the bolt holes in the upper tang. In rare cases it has been noted that improper alignment of piercing blade bolt holes and the bolt holes in the tang can cause the piercing blades to break through the bolt holes.

When installing the piercing blades, the bolts must be freely installed by hand, not with an air impact wrench.

The bolts may start freely, but when the bolt shank, which is larger in diameter than the threads, enters the hole in the tang, the interference can cause side loading to the piercing blades. This can cause the tips to break as they try to force the holes apart, or it may force the tips to seat improperly on the tang which can also cause tip failure. This is not a common issue, but one that should be noted as part of routine tip maintenance to prevent unnecessary costs and downtime. If this situation is encountered, contact the Genesis Parts or Service Departments for further instructions.

PIERCING BLADES

Replacement

1. Remove blades using an air-impact wrench or breaker bar and multiplier.
2. Remove dust and debris from blade seats; wipe down with a rag and solvent.
3. Lightly file deformities from blade seat edges. Do not sand or grind face of blade seats.
4. Install new, clean blades. Lubricate the threaded holes in the blade and on the bottom of the bolt head where it will contact the blade.
5. Snug lubricated blade bolts by hand to hold them in place; push blades up and into the upper and rear surfaces of the seats.
6. Torque bolts to 1/3 of the final torque value.
7. Check for firm contact against blade seats.
8. With a feeler gauge, confirm there is a gap where the blades meet. Gap width by model is shown below the graphic to the right. A very narrow gap may be confirmed by shining a flashlight from below the blades and seeing light pass through. If the gap exceeds the specified limit, call the Genesis Service Department. If no gap exists, remove blades, lightly grind facing surfaces and repeat steps 5-8.
9. Torque bolts to 2/3 final value, and then to final value, using a cross bolt pattern.

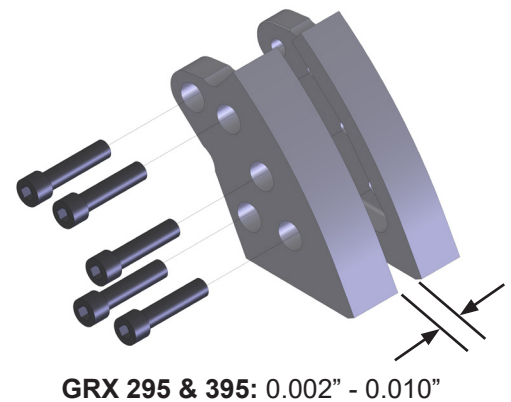

NOTICE

Piercing blade bolts must be lubricated and torqued as specified in the Genesis Fastener Manual.

Correct clamping force is required to keep tips from moving on their seats. Over-tightening can cause bolt shanks to stretch, losing their clamping force. Loose bolts will cause the seating areas to erode.

GUIDE BLADES

After adjusting the AutoGuide, check guide blade tolerances. When necessary, shim the guide blade to keep the gap within the specifications listed in the Blade Gap table below.

Rotate the guide blades when worn to a 1/8" (3 mm) radius. Replace a guide blade when more than 0.075" (2 mm) of shims are required to keep the blade gap within tolerance.

Dual guide blades, one on either side of the lower jaw, allow for a wider tip-to-guide blade gap than is used between the main cutting blades. Friction and heat buildup cause piercing blades to expand, reducing clearance, possibly to the point of blade interference. Therefore, in most applications, it is beneficial to maintain a wider gap at the guide blades.

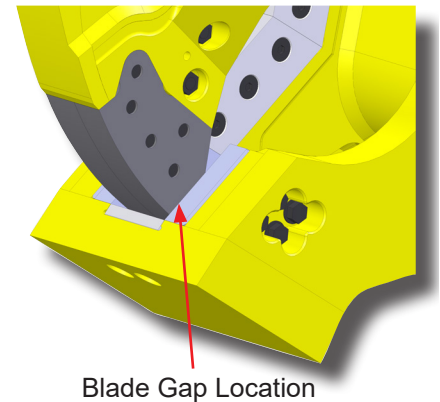

Guide Blade to Piercing Blades Gap		
Model	Minimum	Maximum
195 - 395	0.010"	0.020"

Shimming

Slowly close the jaw so the upper piercing blades begin to bypass the guide blades. Stop the jaw and check the gap between the guide blades and piercing blades. Cycle the jaws slowly, stopping at several points along the piercing blades to check the gap each time.

Shim the guide blades as needed to keep the gap within the tolerances listed in the Blade Gaps table.

To install shims, loosen blade bolts and slide shims between the guide blade and guide blade seat. Re-torque bolts and recheck the gap.

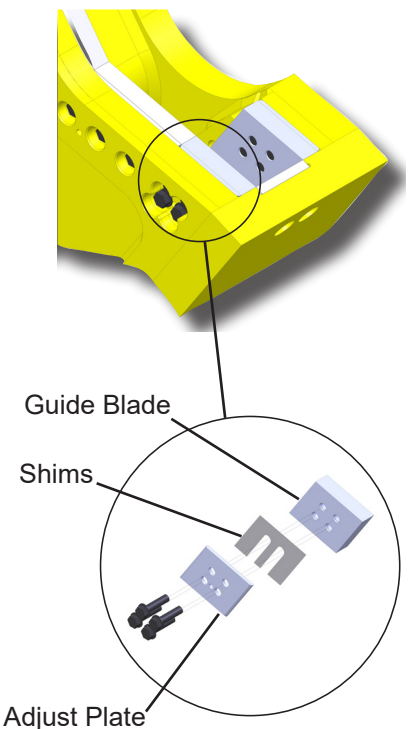

GUIDE BLADES

Rotation

Remove the blade bolts, guide blade and shims. Rotate the blade end-for-end or side-to-side; reinstall and torque bolts. Check gap; shim if required.

If the guide blade faces are excessively worn, the blades cannot be rotated. Excessively worn blades will have uneven surfaces that, when placed upon guide blade seat surfaces, will not be supported and will break, resulting in blade seat damage.

Replacement

Remove guide blade and shims. Install new guide blade with no shims. Check blade gap and shim as needed.

Adjustment Plates

Do not remove the guide blade adjustment plates from the lower jaw during routine blade rotation or replacement. These plates are custom-machined for each jaw set and need only be replaced when lost, damaged or extremely worn.

Inspect the top of the adjustment plate for burrs, nicks or other imperfections that may prevent proper seating of the guide blade and cause errant blade gap readings. Clean the adjustment plate as necessary. Inspect the blade seat for damage or imperfections and clean or repair as necessary.

Replacement plates can be ordered from your Genesis dealer or the Genesis parts department with the serial numbers of your attachment and jaw set.

Offset dowel or fastener holes are located in each adjustment plate. When replacing adjustment plates, make sure these are aligned with the corresponding holes in the blade seat.

Do not grind on blade seat areas.

PRIMARY AND SECONDARY BLADES

Proper maintenance of the primary and secondary blades, or cutting blades, is required for optimal performance. Blade rotation extends blade life and improves cutting performance. Shimming to maintain blade tolerances helps prevent jamming. Dull blades make the excavator hydraulic system work harder and may cause structural damage to the shear.

Inspect blades every eight hours of operation. Re-torque loose bolts and replace broken bolts. Grind away dents or mushrooming of blade edges at the end of each day to prevent upper jaw deflection, excessive blade wear and undue stress to upper and lower jaws.

Rotate blades to use all four cutting edges. Always use Genesis-approved blades. Blades that do not meet Genesis specifications can cause major problems, and using them may void the warranty.

Before performing any blade maintenance, read, fully understand and follow these safety rules.

Wear personal safety equipment including gloves, safety glasses, safety boots and proper clothing.

Safe blade maintenance requires two people - one to steady the blade while the other loosens the bolts.

Blades are heavy and may fall out of the blade seat if not adequately supported. Bystanders must stand clear.

Never strike a blade with a hardened steel tool. The blade may fragment, creating sharp flying debris.

Removal

Loosen the bolts on one blade at a time, enough to loosen the blades.

If blades remain tight, insert a 7/16" brass drift pin into the through-hole on the lower jaw. Tap the drift pin with a hammer until the blade is loose.

Carefully remove bolts and blades.

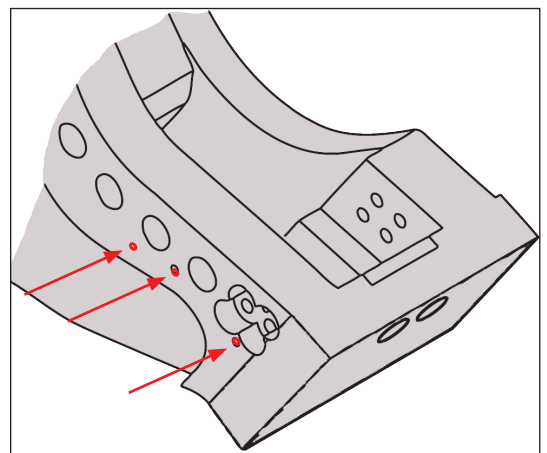

PRIMARY AND SECONDARY BLADES

Adjustment Plates

Do not remove the adjustment plates from the lower jaw during routine blade rotation or replacement. These plates are custom-machined for each shear and need only be replaced when lost, damaged or extremely worn.

Inspect the top of each adjustment plate and seat for burrs, nicks or other imperfections that may prevent proper seating of the blades and cause errant blade gap readings. Clean the adjustment plates as necessary.

Replacement plates can be ordered from your Genesis dealer or the Genesis Parts Department with the serial number of your shear.

Offset dowel or fastener holes are located in each adjustment plate. When replacing adjustment plates, make sure these holes are aligned with the corresponding holes in the blade seat.

Do not grind blade seat areas.

Rotation

Rotate blades when the cutting edges are worn to a 1/8" (3 mm) radius.

Recommended rotation intervals are approximately 40-80 hours, depending on the material being processed. Thin materials may require shorter rotation intervals. Blades must be replaced when all four edges are worn to 1/8" (3 mm) radius.

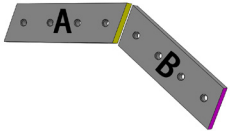
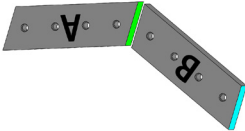
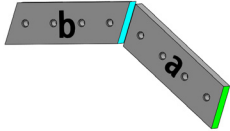
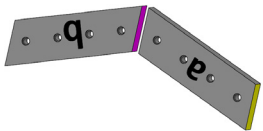
Original Blade Configuration	First Rotation Rotate both blades end-for-end	Second Rotation Rotate both blades front-to-back and exchange seat positions	Third Rotation Rotate both blades end-for-end
			

The following chart may be copied and used to track blade rotation.

40 - 80 Hours	Date	Hour Meter	Performed By
Installed			
Rotation 1			
Rotation 2			
Rotation 3			

PRIMARY AND SECONDARY BLADES

Blade Gap

After each blade rotation, shim the lower blades to keep the gap within the specifications listed in the table below. Do not shim the upper blades. Use only Genesis shim kits.

Cutting Blade Gaps		
Model	Minimum	Maximum
195 - 395	0.005"	0.015"

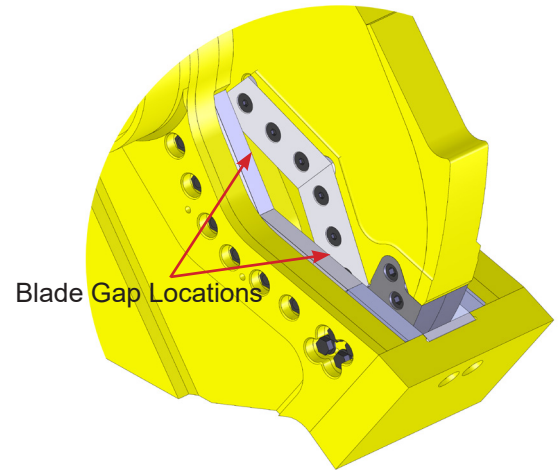

Blade Gap Measuring Procedure

Slowly close jaws until blades begin to bypass. Stop the jaw and check the gap with a feeler gauge.

Cycle the jaws slowly and continue checking the gap at several points along the entire length of the blades.

Note: The gap will be consistent along the entire length of the blades if they have been rotated and shimmed correctly.

If the blade gap exceeds the maximum listed on the table above, shim the lower blades. Blades must be replaced when shims exceed 0.060".

Shimming

Loosen blade bolts.

Install shims between the blades and adjustment plates as needed to bring into tolerance.

Torque bolts to spec and recheck the tolerances.

Do not use more than 0.060" of shims.

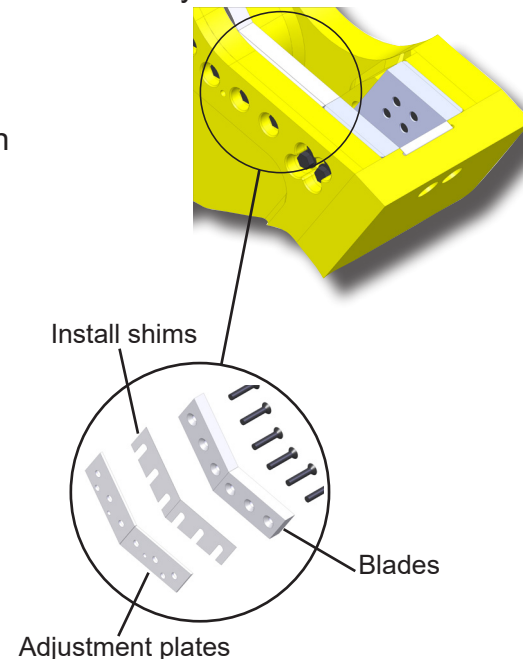

RAZOR BLADE

Check the razor blade for wear every eight hours of operation. Rotate when worn, using the edges in the sequence indicated by the illustration.

After rotation, check the gap between the razor blade and piercing blades. If the gap exceeds the maximum tolerance after new piercing blades have been installed, the razor blade must be replaced. Do not shim the razor blade.

Set-screws should be installed in unused bolt holes to prevent thread and hole damage. Replace set-screws when lost or damaged.

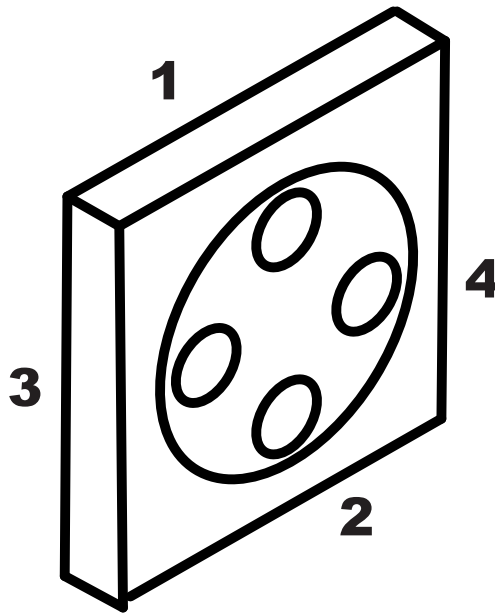

CRACKER & PULVERIZER JAW SET MAINTENANCE

Blade, tooth, pocket and blade seat maintenance greatly affects performance. To maximize performance and optimize the life of replaceable parts, follow all instructions for checks, adjustments and maintenance described in this section, at the intervals listed in the maintenance schedule in this manual.

Before performing maintenance, read, fully understand and follow these safety rules.

Wear personal safety equipment including gloves, safety glasses, safety boots and proper clothing.

Safe blade maintenance requires two people - one to steady the blade while the other loosens the bolts.

Blades are heavy and may fall out of the blade seat if not adequately supported. Bystanders must stand clear.

Never strike a blade with a hardened steel tool. The blade may fragment, creating sharp flying debris.

Pulverizing Teeth

As teeth become worn, they need to be rotated, built-up or replaced. To help customers determine and monitor how far processor teeth have worn from their original shape, Genesis has tooth build-up templates available.

Each template is sized and formed to that tooth's original shape and features three lines that indicate wear level. Simply place the template over the tooth to determine the amount of wear and build-up required or if replacement is needed.

See the following page for part numbers, and contact your local Genesis dealer or the Genesis Parts Department to order.



Line 1	½ inch wear - schedule maintenance to flip or rotate in jaw
Line 2	1 inch wear - flip, rotate in jaw or build up
Line 3	1½ inch wear - replace, if all points are worn on flippable teeth

CRACKER & PULVERIZER JAW SET MAINTENANCE

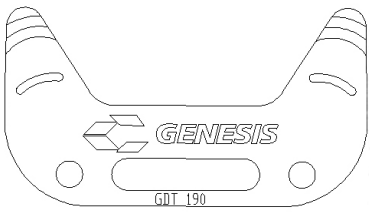
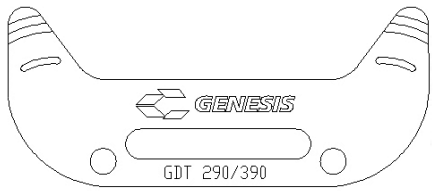
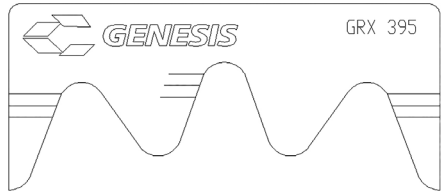
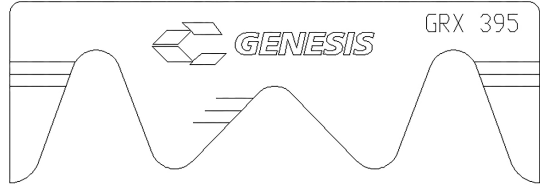
Model	Part Number	Template
295	9102985	
395	9102930	
	9103747	
	9103748	

At the end of each shift, check the condition of pulverizing teeth. Replace any broken bolts, and retorque loose bolts when cool.

Replace teeth when tip becomes severely rounded or flat. A more pointed tooth will process concrete more efficiently.

Pulverizing teeth may be welded to tooth holder if desired.

Concrete Cracking Tips

At the end of each shift, check the condition of the concrete cracking tips. Replace any broken bolts, and retorque loose bolts when cool.

Replace tips when teeth become severely rounded or flat. A more pointed tooth will process concrete more efficiently.

CRACKER & PULVERIZER JAW SET MAINTENANCE

Hard-Surfacing Teeth

When building-up and/or hard-surfacing concrete crushing teeth, Genesis recommends keeping hard-surfacing a minimum of 1.00 inch away from the tooth profile root.

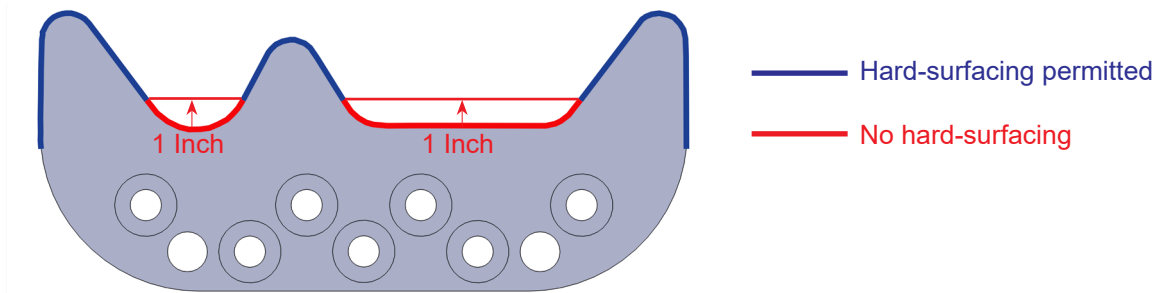

Hard-surfacing in the red areas can lead to premature tooth failure.

Always build-up/hard-surface with the grain of the tooth. Do not weld across the tooth.

Hard-surface material should have less than 10% chrome content and be applied on top of a 7018 root pass.

Cutting Blades

Proper maintenance of the cutting blades is required for optimal performance. Blade rotation extends blade life and improves cutting performance. Shimming to maintain blade tolerances helps prevent jamming.

Inspect blades every eight hours of operation. Re-torque loose bolts and replace broken bolts. Grind away dents or mushrooming of blade edges at the end of each day to prevent upper jaw deflection, excessive blade wear and undue stress to jaws.

Rotate blades to use all four cutting edges. Always use Genesis-approved blades. Blades that do not meet Genesis specifications can cause major problems, and using them may void the warranty.

Blade Removal

Loosen the bolts on one blade at a time, enough to loosen the blades.

Carefully remove the bolts and blades.

GENERAL WELDING GUIDELINES

Build-up and hard-surfacing are welding procedures that protect the parent material of the jaws and keep the blades in good adjustment. Build-up is the welding procedure that restores the jaws to their original shape. Building up the jaws helps protect the blades and increases the life of the attachment. Hard-surfacing is the welding material added over the parent material (or build-up material) to create a wear-resistant surface.

Welding should not be performed until the jaws are work-hardened. Work-hardening can take up to 80 hours. However, jaws must not wear lower than the height of a new blade. If either jaw wears down lower than blade height, immediately stop operating the attachment and perform build-up and hard-surfacing as described in the following pages of this manual.

When welding around blade seats or the piercing tip tang area, maintain the factory machined seat radius. If the rounded grooves are welded up, use a die grinder with a carbide tool to recut these areas to their original profile. Leaving a squared edge will eventually cause structural cracking. The radius provides a broader area to absorb structural stress.

Welding Ground Clamp

Disconnect all battery ground cables or shut off master battery switch, if equipped. Failure to do so may cause excavator electrical problems, including permanent damage to onboard computer systems.

Connect ground clamp as close as possible to the area being welded without allowing current to pass through the pivot group, cylinder pin, cylinder, swivel, motor, gearbox or slewing ring.

If you are welding on the lower jaw, connect weld clamp to the lower. If you are welding on the upper jaw, connect to the upper but not to the cylinder clevis. If needed, weld a piece of steel to the area for the grounding clamp and cut the piece off when welding is completed.

Welding Rules

Before you begin:

- Remove adjacent blades, as preheating and welding may cause blade damage.
- Wearing an approved respirator, grind the area to clean it, removing all existing hard-surfacing.
- Preheat area to 350° F (177° C). Maintain this temperature throughout the procedure. Do not exceed 450° F (232° C) interpass temperature.

During welding:

- Always grind and weld with the grain of the material.
- Peen each weld pass to relieve stress and harden the welds.
- Do not undercut the ends of the welds.
- Do not start or stop welds directly above a bolt hole or in the apex of the jaw.

After welding maintenance is complete:

- Cover the area with a heat blanket and allow it to cool slowly, approximately eight hours.
- Do not put the attachment into operation until the welds have been allowed to cool.

HARD-SURFACING

Do not apply hard-surfacing directly to the parent material as this could cause toe cracking, and the hard-surfacing will break away.

Procedure:

Follow the General Welding Guidelines and Rules.

Apply a single pass stringer bead pattern, with the grain, using E7018 electrode. Peen each pass.

Do not apply a stringer directly on the edge. Start the first pass 1/4" from the edge.

Stagger the ends of the stringer welds so they do not end in a straight line.

Cap each stringer bead with one pass of GenWire or GenRod to hard-surface. Do not apply more than two layers of hard-surfacing. Peen each pass.

Grind the ends of all stringer welds, with the grain to taper 1" to 1-1/2" (25 - 38 mm) to the parent material.

See the following pages for hard-surfacing illustrations and instructions specific to each area of the jaws.

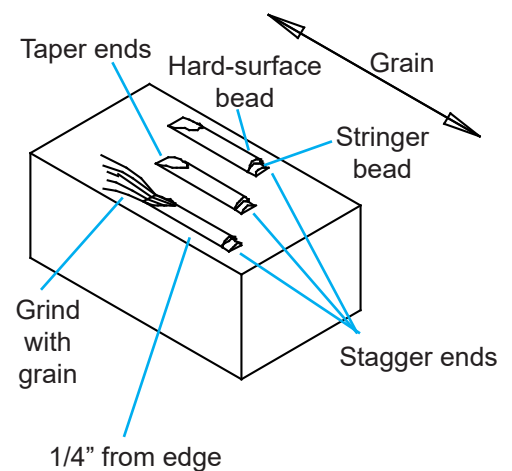

SHEAR JAW BUILD-UP

Procedure:

Follow the General Welding Guidelines and Rules.

Determine the area to build up, using a straight-edge or square. Jaws must not wear lower than the height of a new blade. Use a new blade to help determine build-up height for the jaw.

Build up the jaw to slightly higher than the original parent material profile with E7018. Apply single passes in each line with the grain of the steel, peening after each pass. Illustrations on the following page (for hard-surfacing patterns) indicate the grain of the steel.

Protection strips, or raised areas under or around blade seats, must be built up and maintained during build-up procedure using E7018 or equivalent. Illustrations on the following pages (for hard-surfacing patterns) indicate protection strips in blue.

These areas should be maintained between blade height and 0.010" lower than blade height. These areas protect the bottom unused edges of the blades as well as reduce the chance for material to catch on the bottom of the blade during jaw open functions, which causes blades to move in their seats.

Denting, deformation or build-up higher than blades in these areas may cause upper jaw deflection, excessive blade gaps, wear to blade faces and undue stress to upper and lower jaws.

After build-up is complete, grind material to be flush with a new blade.

Note: Closely monitor areas above guide blade bolt countersinks and below front two upper blade bolt countersinks. These are high-wear areas. If allowed to wear too far, parent material starts to fold into the countersinks, and it becomes time-consuming to clean out this area when access is needed for blade rotation and replacement.

SHEAR JAW HARD-SURFACING PATTERNS

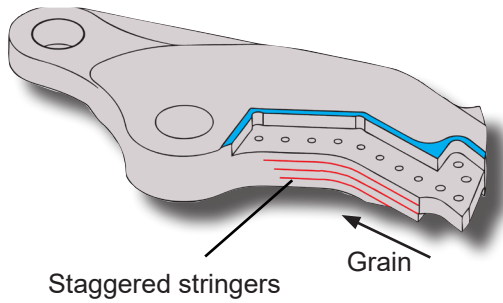

Upper Jaw

Single passes approximately 1" apart. Begin just behind the piercing blade seats and continue toward the throat. Use three to five stringers, depending on the shear model.

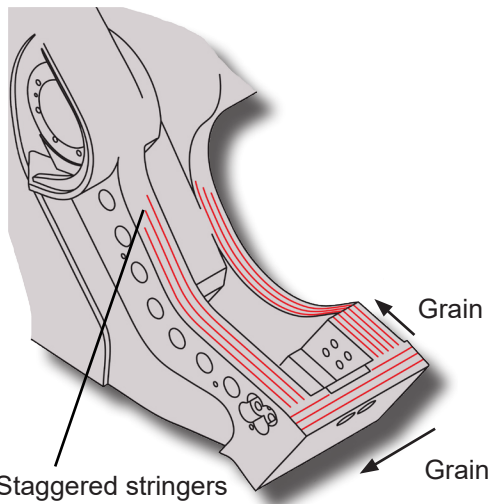

Lower Jaw

Single passes approximately 1" apart. Work across the top of the chin plate and along the lower jaw toward the throat. Use two to three stringers, depending on the shear model.

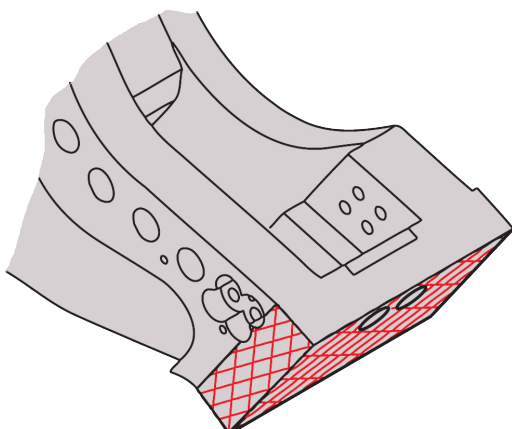

Lower Jaw Chin

Crosshatch the chin plate with stringer beads at 45° angles to form 1" squares.

CRACKER JAW WELDING MAINTENANCE

Procedure:

Follow the General Welding Guidelines and Rules.

Determine the area to build up, using a straight-edge or square. Do not allow jaws to wear to more than a 3/4" radius on edges of tool.

Build up the jaw to slightly higher than the original parent material profile with E7018. Apply single passes in each line with the grain of the steel, peening after each pass.

See drawings for grain, as indicated by arrows. (Red lines indicate hard-surfacing pattern.)

After build-up is complete, grind material to be flush with the flat surfaces of the tool or, if building up a blade seat, grind material to be flush with a new blade.

Hard-Surfacing Patterns

Where parallel lines are shown, apply single passes approximately 1" apart. Cover exposed faces with a crosshatch pattern with stringer beads at 45° angles to form 1" squares.

Hard-surfacing patterns are indicated by red lines in the drawings. Crosshatch may be used in place of straight stringers on any flat areas of the jaws and on the outside of the upper jaw.

Do not crosshatch the curved areas of the jaws near the pivot. Use only straight stringers on these areas.

Follow hard-surfacing instructions on the following page.

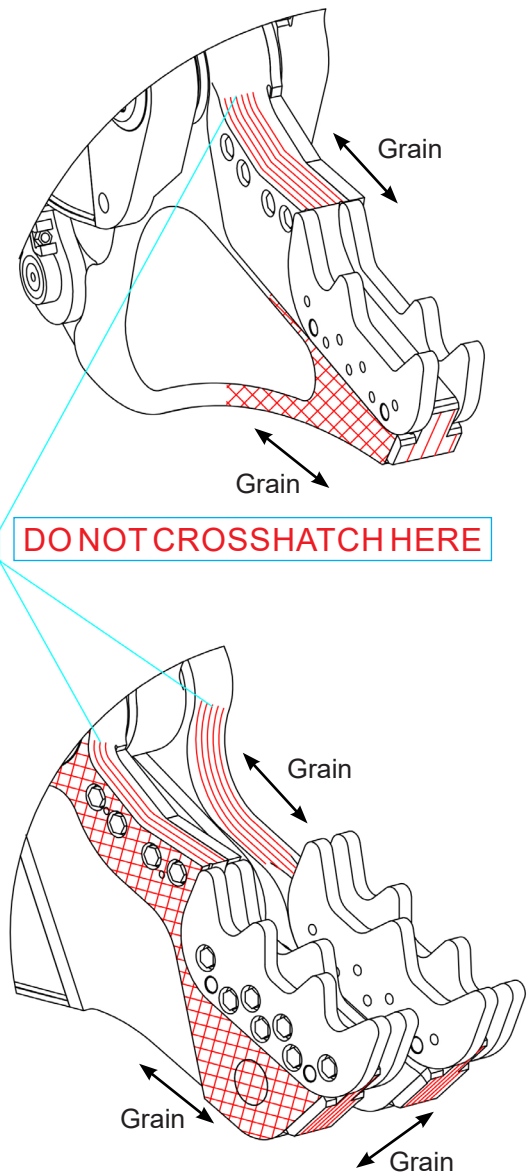

HYDRAULIC/ROTATION MAINTENANCE

Hydraulic Requirements

Operating the attachment below the recommended flow and/or pressure range will adversely affect performance and may damage the rotate motor.

Operating the attachment above the recommended flow and/or pressure range may damage the attachment and its hydraulic components.

Model	Flow	Pressure
195	40-60 GPM 151-227 LPM	4500-5500 PSI 310-380 Bar
295	60-100 GPM 227-379 LPM	
395	80-100 GPM 303-379 LPM	

Rotation Valve Input

For cooler and more efficient hydraulic system operation, set the input pressure as indicated in the chart.

Model	Flow	Pressure
195 & 295	3-5 GPM 11-19 LPM	1500-1900 PSI 103-131 BAR
395	7-11 GPM 26-42 LPM	1900-2100 PSI 131-145 Bar

Rotation Valve Settings

When checking the crossover relief valve settings, put pressure gauges on both diagnostic ports. Stall attachment rotation in clockwise direction. Increase supply pressure until pressure at gauge on crossover stops rising. This is the crossover relief setting. Increase supply pressure to achieve approved crossover relief value. Repeat procedure in counter-clockwise direction. Then lower supply pressure back to approved value.

Note: with supply set at 2000 PSI, you should not hear oil bypassing in the crossover when stalling the rotation motor. If bypass is heard, either the crossover is set lower than 2200 PSI or the supply is set higher than 2200 PSI.

HYDRAULIC/ROTATION MAINTENANCE

GenFlow Regeneration Valve

Regeneration valves feature GenFlow adjustment cartridges to control the timing of the shift between speed and power modes. When the cartridge is properly set, the attachment closes rapidly until it begins to cut. The valve shifts, slowing jaw close and increasing power. You may hear a squeal or hiss as this happens. The valve shifts back into speed mode after the cut is complete.

Cartridges are factory-set, turned out approximately five turns. This setting is appropriate for most applications. However, the cartridges may be custom-set if necessary. Adjust the cartridge on the master regeneration valve only; this will control the adjustment of the slave regeneration valve as well.

Regeneration valve adjustment is a two-person job. The ground crew must be in full view of the operator at all times and must stand clear of the attachment jaws when cycling.

Regeneration Valve Adjustment

Check the cycle time when the hydraulic fluid is warmed up, timing from full open to full closed and back to full open.

To shift into power mode sooner, turn adjustment cartridge out (counter-clockwise). To shift into power mode later, turn in (clockwise).

Loosen the lock nut with a 9/16" socket.

Turn cartridge 180° (half-turn, 145 PSI) with a 5/16" allenhead socket.

Tighten lock nut.

Check the cycle time.

Repeat until the preferred balance of speed and power is met. Final adjustment may require less than a half-turn.

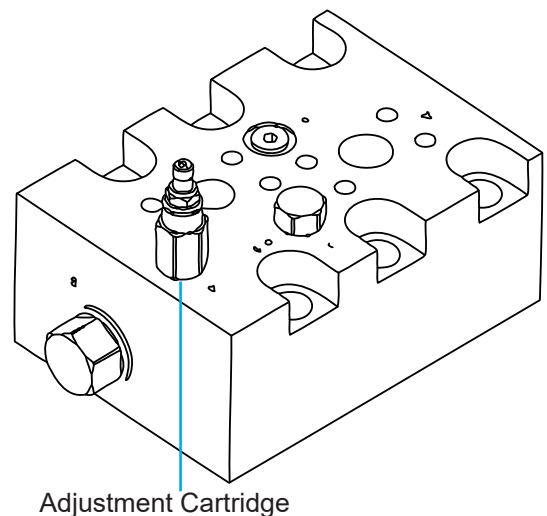

Shut off the excavator and disable the hydraulics per OEM instructions before adjusting the cartridge.

GENFLOW REGENERATION VALVE - HOW IT WORKS

Jaw Close in Regeneration: Oil that would normally leave the rod end of the cylinder and return to the tank is diverted to the bore end of the cylinder, increasing flow by approximately 50 percent and speeding up jaw close. In this mode, oil pressure on both rod and bore sides of the cylinder piston are basically equal and, although this speeds up the cylinder extend speed, it results in pressurized fluid on the rod side. If left in this mode, cylinder power is greatly reduced.

Jaw Close in Power Mode: To provide full power, when the upper jaw hits the material, the pressure rises. Once pressure exceeds the adjustment cartridge settings, it then shifts the rod oil back to the excavator hydraulic tank instead of the bore end of the cylinder. Pressure in the rod also drops, allowing full force from the bore pressure to be applied to the upper jaw for full cutting.

Jaw Open: Oil goes to the rod end of the cylinder, and bore oil goes back to the tank.

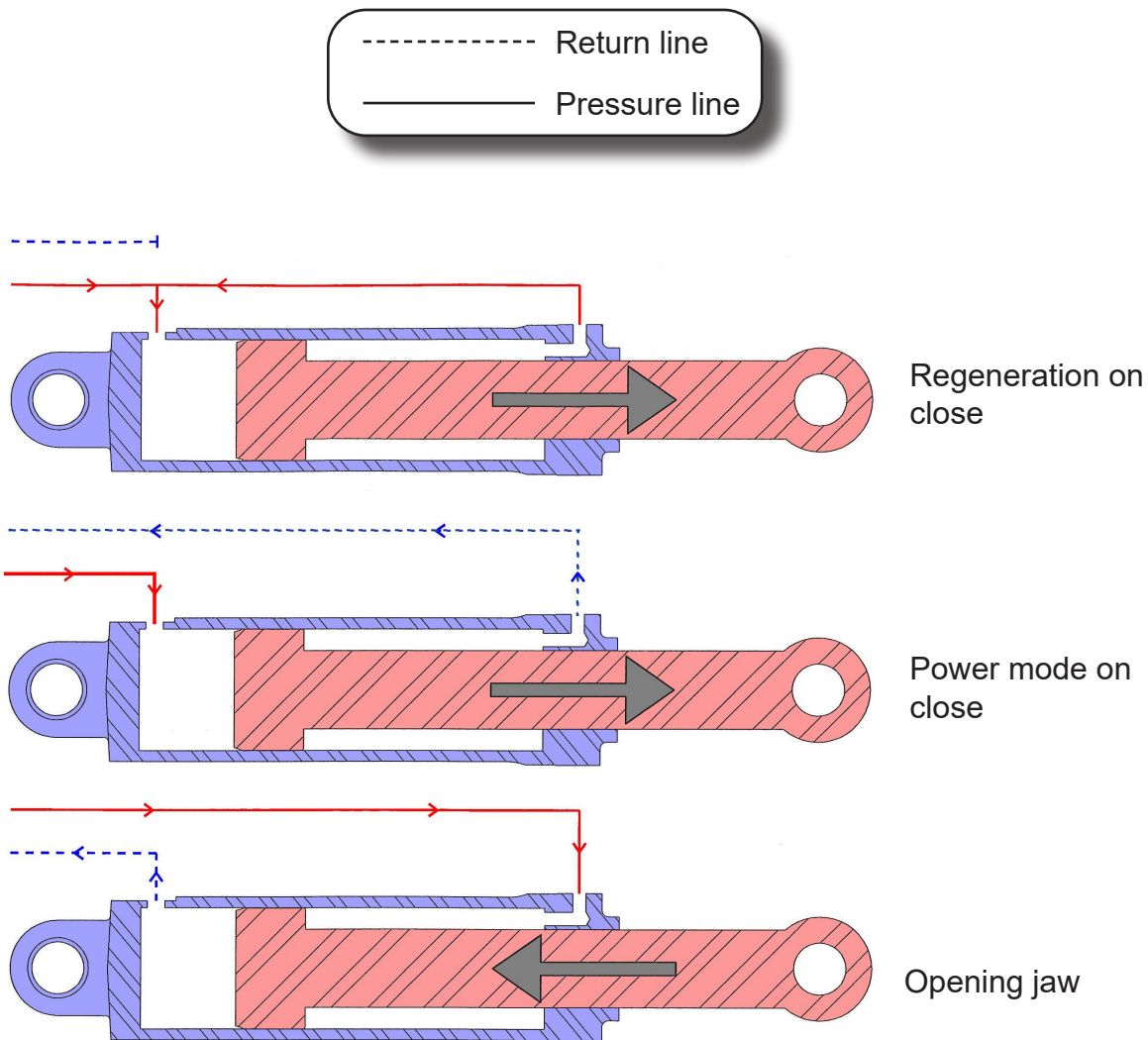

GENFLOW REGENERATION VALVE

GRX 295

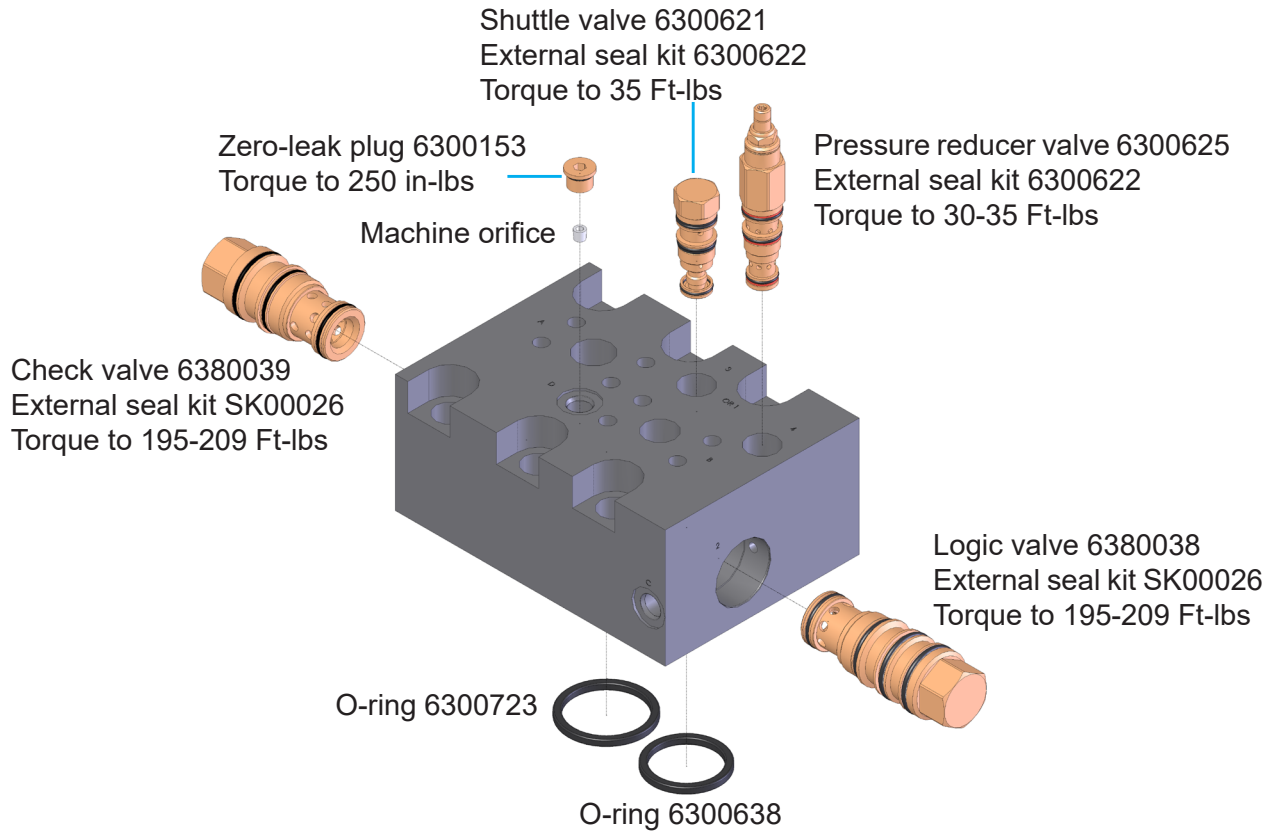

GRX 395

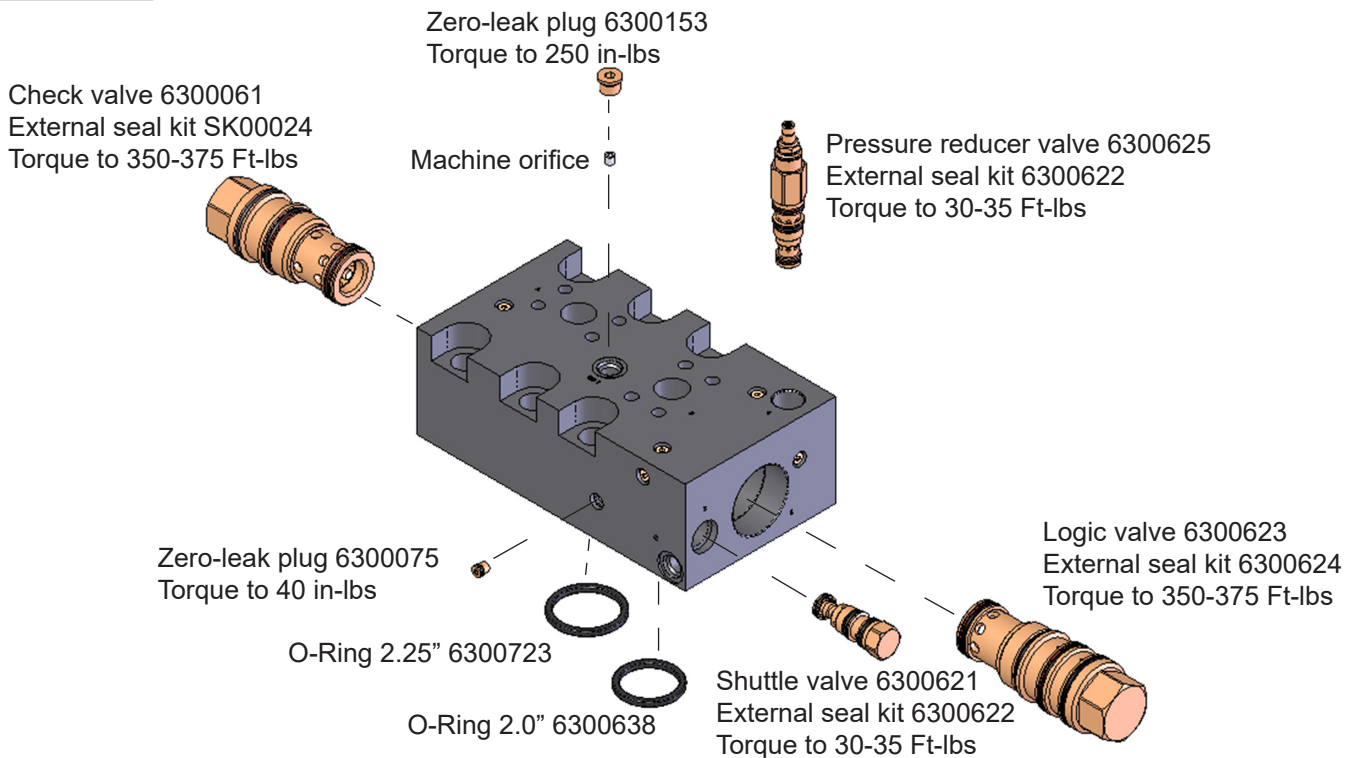

SLEWING RING MAINTENANCE

Visually check slewing ring (rotation bearing) bolts every eight hours of operation. Do not reuse or re-torque these bolts. Loose or broken bolts, along with the bolts on either side, must be immediately replaced.

The bolts that secure the slewing ring are critical for safe attachment operation. Improper torque may cause the bolts to fail and the attachment to break free, which may result in serious personal injury and equipment damage. Improper torque will also cause uneven slewing ring wear.

Rotating components must be greased daily. Grease fittings are located on the outside of the slewing ring and on the inside of the rotating head assembly. Grease locations are marked with decals.

Grease each fitting and then rotate the attachment two full rotations.

For normal conditions above 32°F (0°C), use a lithium-based, premium grade 2 extreme-pressure grease. For temperatures below 32°F, use a grade 0 grease. **Do not use grease containing Molybdenum (Moly).**

Genesis GLG-2™ anti-wear, extreme-pressure lithium grease, PN 6302601, is recommended for all temperature conditions.



Stand clear when the attachment is being rotated. Always stay in clear view of the operator.

ROTATION CIRCUIT

To meet diverse customer needs, Genesis offers two rotation valve options. They vary in mounting, function, factory-supplied and customer-supplied parts, and operating advantages.

Valves are factory-set and should not need adjustment. If you believe adjustment is necessary, contact the Genesis Service Department.

All rotation circuits use the same procedure for setting flow:

- Rotate attachment, timing one complete revolution.
- Adjust corresponding flow control until revolution time is 14-16 seconds.
- Repeat in opposite direction.

Auxiliary Valve Rotation

Setting the crossover reliefs:

1. Increase supply pressure to the rotation valve to 2500 PSI.
2. Install pressure gauges on relief test ports.
3. Plug hoses at motor or secure the attachment from rotating.
4. Pressurize the valve to rotate.
5. Adjust the corresponding relief valve to the pressure specified in the table for rotation valve settings.
6. Repeat for the other direction.
7. Reduce supply pressure to the pressure-reducer valve setting specified on the table for rotation valve settings.

Gear Pump Rotation

Setting the crossover reliefs:

1. Install a pressure gauge on the unloading valve, unplug the wires to the directional valve, and energize the valve on the unloading valve.
2. Adjust the unloading valve to 2500 PSI.
3. Reconnect the wires to the directional valve.
4. Plug hoses at motor or secure the attachment from rotating.
5. Press the switch to rotate left or right.
6. Adjust the corresponding relief valve to the pressure specified in the table.
7. Repeat for the other direction.
8. Set the unloading valve before operating.

Setting the unloading valve:

1. Install a pressure gauge on the unloading valve, unplug the wires to the directional valve and press the switch to rotate left or right.
2. Adjust the unloading valve to the pressure specified in the table.
3. Plug the wires back into the directional valve.

ROTATION CIRCUIT

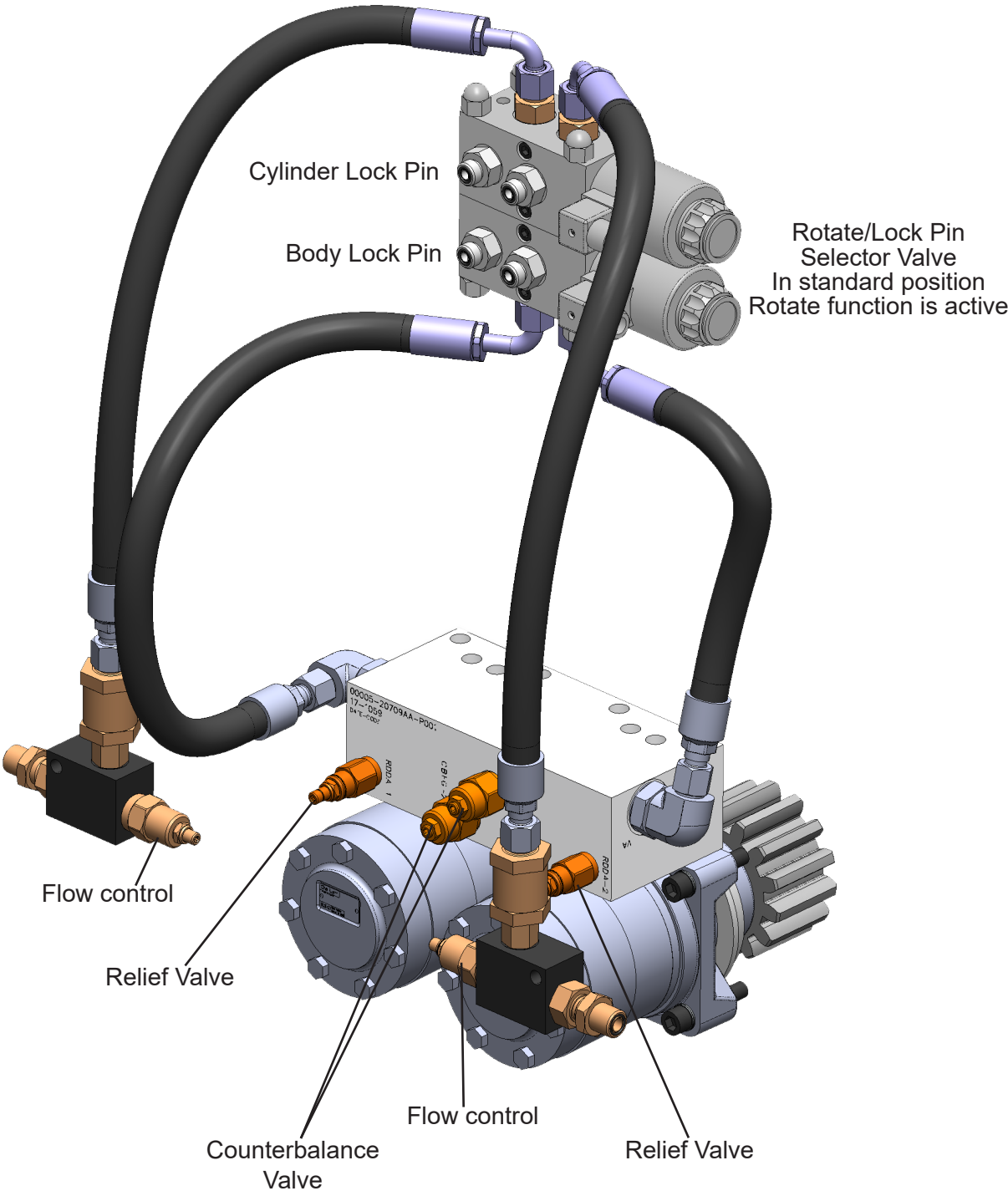

TROUBLE-SHOOTING GUIDE

Attachment		
Symptom	Possible Cause	Possible Solution
Lacks power	Circuit not getting full pressure from excavator	Check hydraulic pressure at port block
	GenFlow cartridge needs adjustment	Make adjustments following procedure listed in this manual
	Attachment cylinder or swivel bypass	Check for bypass and replace seals if needed
	Pilot check seals leaking	Replace seals
Poor cutting	Material size is beyond attachment appetite range	Consult the factory
	Worn blades (shear jaw set)	Refer to Jaw and Blade Maintenance in this manual
	Excess blade gap (shear jaw set)	
	Pilot check seals leaking	Replace seals
Poor piercing (shear jaw set)	Piercing blades or razor blades are worn	Refer to Jaw and Blade Maintenance in this manual
Slow jaw cycle time	Genflow cartridge needs adjustment	Make adjustments following procedure listed in this manual
Material jamming	Excess blade gap	Refer to Jaw and Blade Maintenance in this manual
	Insufficient blade gap between piercing tips and guides	
	Worn blades (shear jaw set)	
	Worn piercing blades (shear jaw set)	
Slow jaw cycle in one direction	Excess back pressure on return side of cylinder	Check excavator main control valve and pilot check seals
Jaws drift closed or can be pushed closed	Excavator control valve	Check excavator main control valve
	Attachment cylinder or swivel bypass	Check for bypass and replace seals if needed
	Pilot check seals leaking	Replace seals
	Bleed-down orifice plugged	Clean and replace orifice

TROUBLE-SHOOTING GUIDE

<u>Rotator</u>		
Symptom	Possible Cause	Possible Solution
Does not rotate	Blown fuse	Replace fuse
	Electrical problem	Test for 24V at plugs on directional valve while depressing foot switch
	Incorrect pressure settings	Set pressures
	Faulty components	Contact Genesis to replace valve
Does not rotate in one direction	No electrical power to one side	Test for 24V at plugs on directional valve while depressing foot switch
	Faulty directional control valve	Check if directional control valve shifts both ways while actuating foot switch in both directions
	Faulty cartridge	Contact Genesis to replace valve
Rotator chatters	Electrical short	Test for continuity through circuit
	Low supply flow	Back out flow controls
	Pressure settings too high	Set pressures
	Supply flow too high	Reduce flow from excavator control valve
	Power to both rotation solenoids at the same time	Test for 24V at plugs on directional valve while depressing foot switch
Rotates faster in one direction	One flow control cartridge set higher than the other	Set flow control
Rotates too fast or too slow	Flow control out of adjustment	Set flow control
Rotation speed changed from original setting	Jam nut loosened on rotation flow control valve	Check jam nuts on rotation flow control valve; set pressures
	Faulty cartridge (contamination)	Replace cartridge
	Faulty directional control valve	Replace valve
	Pressure set too low	Set pressures

TROUBLE-SHOOTING GUIDE

Lock-Pin

Symptom	Possible Cause	Possible Solution
Lock-pin not operating	No electrical power	Test for 12V at plugs on selector valve while depressing toggle switch
	Lock-pin selector valve not shifting	Replace with Genesis replacement valve
	Tool misalignment	Move tool to correct alignment
	Hoses between lock-pin cylinder and valve connected incorrectly	Verify that hoses are routed to factory-specified ports on cylinder, swivel and control valve
	Swivel leaking internally	Test passes on swivel for bypass and repair if faulty

WARRANTY

Claim Procedure

Notify the Genesis Service Department of the potential warranty claim prior to making the repair. Digital pictures are very helpful for diagnosing problems and recommending repairs.

Contact the Genesis Service Department before making alterations, changes or repairs to any component that is going to be considered for warranty. Not doing so will void all Genesis warranty consideration.

The Genesis Service Department will issue an authorization number to track the repair costs, outgoing parts, and/or defective parts returning to the factory.

Replacement parts must be ordered using a purchase order number. Shipping is standard ground. Overnight shipping is available by request, and Genesis will not cover the shipping charge.

When the repair is complete, submit an invoice to the Genesis Service Department within 30 days. Include itemized internal labor reporting, parts lists and invoices for outside contractors. Reference the authorization number on all invoices.

When returning parts for warranty consideration, include a copy of any related Genesis paperwork along with any other necessary documentation to ensure proper processing and credit. The Genesis Service Department will provide the necessary forms.

Your account will be credited when the warranty claim is accepted.

Blade Warranty

Standard warranty on blades will only be considered on the first edge, and wear on the edge must be 1/8" radius or less. Genesis does not warranty cutting blades that are cracked or broken from top to bottom (perpendicular to the long edge of the blade). Genesis also does not cover fasteners, the labor to replace wear components or collateral damage, such as blade seats, from broken blades, the piercing blade tang or adjustment plates.

Please direct any questions to the Genesis Service Department: 715-395-5252

PARTS ORDER POLICY AND PROCEDURE

Parts Orders Should Include

- Purchase order number
- Model and serial number of attachment
- Part number and quantity needed
- Shipping and billing address
- Method of shipment or required delivery date

Placing Orders

Orders may be placed by phone or e-mail. To e-mail an order, use the form on the following page or your purchase order form. Contact information is located at the front of this manual.

Part Numbers

Part numbers are listed in a separate Parts Manual or, if included, the Parts section of this manual. Contact the Genesis Parts Department with questions regarding part numbers, availability and pricing.

Shipping

All orders will be shipped best way surface unless an alternate shipping method is requested. Shipping charges are not included in the purchase price of parts.

Invoices

All invoices are due upon receipt. Any accounts with invoices open beyond 60 days are subject to review and may be placed on C.O.D. status without further notice.

Returns

Many unused Genesis parts may be returned with proper documentation. Return shipping is the responsibility of the purchaser. Credit will be issued upon return, less a 25% restocking fee. Documentation is required for credit of returned parts. Contact the Genesis Service Department at 715-395-5252 for an RGA (Return Goods Authorization) number and form. An RGA must accompany every return. Items shipped without an RGA may be returned to sender.

Warranty Returns

All parts returned to Genesis for warranty consideration must be returned with a completed RGA (Return Goods Authorization) provided by the Genesis Service Department. The form needs to be completed in its entirety, including any additional information requested by the Service Department. Return shipping is the responsibility of the sender and will be credited upon claim approval. A determination to accept or deny the claim will be made based upon the information available to Genesis. Warranty on purchased parts other than wear components is 6 months. There is no warranty period on wear parts or components.



PARTS ORDER FORM

Customer: _____ Date: _____

Phone: _____ Contact: _____

Shipping Address: _____ E-mail: _____

_____ Billing Address: _____

Purchase Order: _____ Shipping Method: _____

Model: _____ Serial Number: _____

Quantity	Part Number	Description	Price

E-mail to the Genesis Parts Department: genesisparts@genesisattachments.com
 For assistance, call 715-395-3488



GENESIS®

The Promise of Performance.

CONTACT INFORMATION

Genesis Attachments

1000 Genesis Drive
Superior, WI 54880 USA

Toll Free: 888-SHEAR-IT
(888-743-2748)

Phone: 715.395.5252

E-mail:
info@genesisattachments.com

Europe/Africa/Middle East Genesis GmbH

Teramostrasse 23
87700 Memmingen, Germany

Phone: +49 83 31 9 25 98 0

Fax: +49 83 31 9 25 98 80

genesis-europe.com

E-mail:
info@genesis-europe.com

Asia Pacific Representative Office

24 Upper Serangoon View #12-28
Singapore 534205

Phone: +65 9673 9730

E-mail:
tchoo@genesisattachments.com

Central America & Colombia

Cra 13A #89-38 / Ofi 613
Bogota, Colombia

Phone: +57 1 610 8160 / 795 8747

E-mail:
contact@themsagroup.com

View and download all manuals: genesisattachments.com/manuals
Patents: genesisattachments.com/products/patents

Rev. 3-27-25