

GENESIS[®]

The Promise of Performance.

Fastener Manual



CONTACT INFORMATION

Genesis Attachments

1000 Genesis Drive
Superior, WI 54880 USA

Toll Free: 888-SHEAR-IT
(888-743-2748)

Phone: 715.395.5252

E-mail:
info@genesisattachments.com

Europe/Africa/Middle East Genesis GmbH

Teramostrasse 23
87700 Memmingen, Germany

Phone: +49 83 31 9 25 98 0
Fax: +49 83 31 9 25 98 80
genesis-europe.com

E-mail:
info@genesis-europe.com

Asia Pacific Representative Office

24 Upper Serangoon View #12-28
Singapore 534205

Phone: +65 9673 9730

E-mail:
tchoo@genesisattachments.com

Central America & Colombia

Cra 13A #89-38 / Ofi 613
Bogota, Colombia

Phone: +57 1 610 8160 / 795 8747

E-mail:
contact@themsagroup.com

View and download all manuals: genesisattachments.com/manuals
Patents: genesisattachments.com/products/patents

PREFACE

To ensure years of safe, dependable service, only trained and authorized persons should operate and service your Genesis attachment. It is the responsibility of the product's owner to ensure the operator and maintenance personnel read, fully understand and follow all instructions in this manual prior to attachment operation or service. Always use good safety practices to protect yourself and those around you.

Important

This manual must accompany the attachment at all times and be readily available to the operator.

Manual Replacement

Should this manual become damaged or lost or if additional copies are required, immediately contact any authorized Genesis dealer or the Genesis Service Department at 888-743-2748 or 715-395-5252 for a replacement.

Possible Variations

Genesis cannot anticipate every possible circumstance that might involve a potential hazard as the owner's requirements and equipment may vary. Therefore, the warnings in this publication and on the product may not be all-inclusive, and you must satisfy yourself that the procedure, application, work method or operating technique is safe for you and others before operating.

Public Notice

Genesis reserves the right to make changes and improvements to its products and technical literature at any time without public notice or obligation. Genesis also reserves the right to discontinue manufacturing any product at its discretion at any time.

Improper operation or improperly performed maintenance may render any warranty null and void.

NOTES

TABLE OF CONTENTS

CONTACT INFORMATION	2
PREFACE	3
Important.....	3
Manual Replacement.....	3
Possible Variations.....	3
Public Notice.....	3
PROCEDURES	6
Cleaning.....	6
Threadlocker.....	6
Anti-Seize.....	7
No Thread Treatment.....	7
THREAD TREATMENT DIAGRAM	8
Mobile Shears.....	8
GRX, GDT, GDR & LXP® Demolition Tools.....	9
GCP Concrete Processor.....	10
GMP, GMP C, GMP D, GSD, GRS, GLS & GCC Linkage Tools.....	11
GHG & GSG Grapples.....	12
BOLT TORQUE SPECIFICATIONS	13
O-RING BOSS & FLAT FACE O-RING TORQUE SPECIFICATIONS	15
BOLT DRIVE SPECIFICATIONS	16
CONTACT INFORMATION	17

PROCEDURES

Reference the product Thread Treatment Diagrams beginning on page 8 to determine which of the following procedures is required.

Cleaning

To ensure proper performance of thread treatment and accurate torque values, clean and degrease **all internal and external threads** prior to application of threadlocker, anti-seize or primer and before installation of hardware.

- Ensure both internal and external threads are free of dirt or debris.
- Use brake cleaner or similar cleaning solvent on all threads to remove any grease or oil.
- Allow threads to dry.

NOTICE

Failure to properly clean threads will cause threadlocker, primer, and/or anti-seize to not properly cure!

LOC

Threadlocker

For bolted connections requiring threadlocker, use **Loctite 263** or equivalent applied using the following procedure:

- Clean and degrease all threads.
- For thru holes or nuts, apply threadlocker to bolt threads.
- For blind holes, apply stripe of threadlocker along the length of the hole (applying to the bolt can cause escaping air to remove threadlocker as the bolt is inserted).
- Torque bolt to specified **Wet Torque Value**, see page 14.

For threaded hydraulic fitting connections, use **Loctite 5452** or equivalent thread sealant in conjunction with **Loctite 7471** primer using the following procedure:

- Clean and degrease all threads.
- Apply Loctite 7471 primer to both external and internal threads and allow to dry.
- Apply threadlocker to 360 degrees of the threads on the male fitting, ensuring adequate coverage.
- Assemble fitting per directions in operator's manual.
- For O-ring boss and flat face O-ring connections, torque fittings to values specified on page 15.

Threadlocker

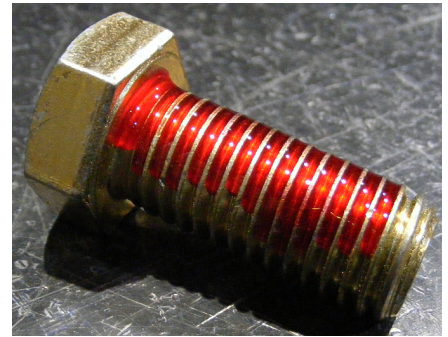

Blind Hole

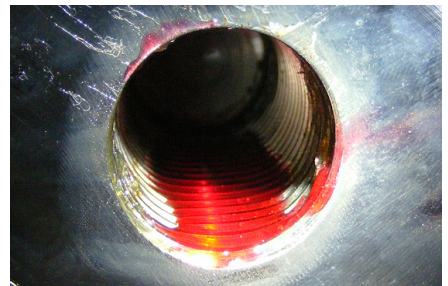

Hydraulic Fitting



PROCEDURES

LUB

Anti-Seize

For bolted connections requiring anti-seize lubrication, use **Loctite LB8008** or equivalent using the following procedure:

- Clean and degrease all threads.
- Apply thin coat of anti-seize to internal and external threads and under bolt head and/or nut, ensuring complete coverage.
- Torque bolt to specified **Wet Torque Value**, see page 14.

Anti-Seize



DRY

No Thread Treatment

- Clean and degrease all threads.
- Torque bolt to specified **Dry Torque Value**, see page 14.

THREAD TREATMENT DIAGRAM

Mobile Shears

Use this diagram to determine what thread treatment, if any, is required for each fastener.

For thread treatment application procedures, see page 6. For prescribed torque values, see page 14.

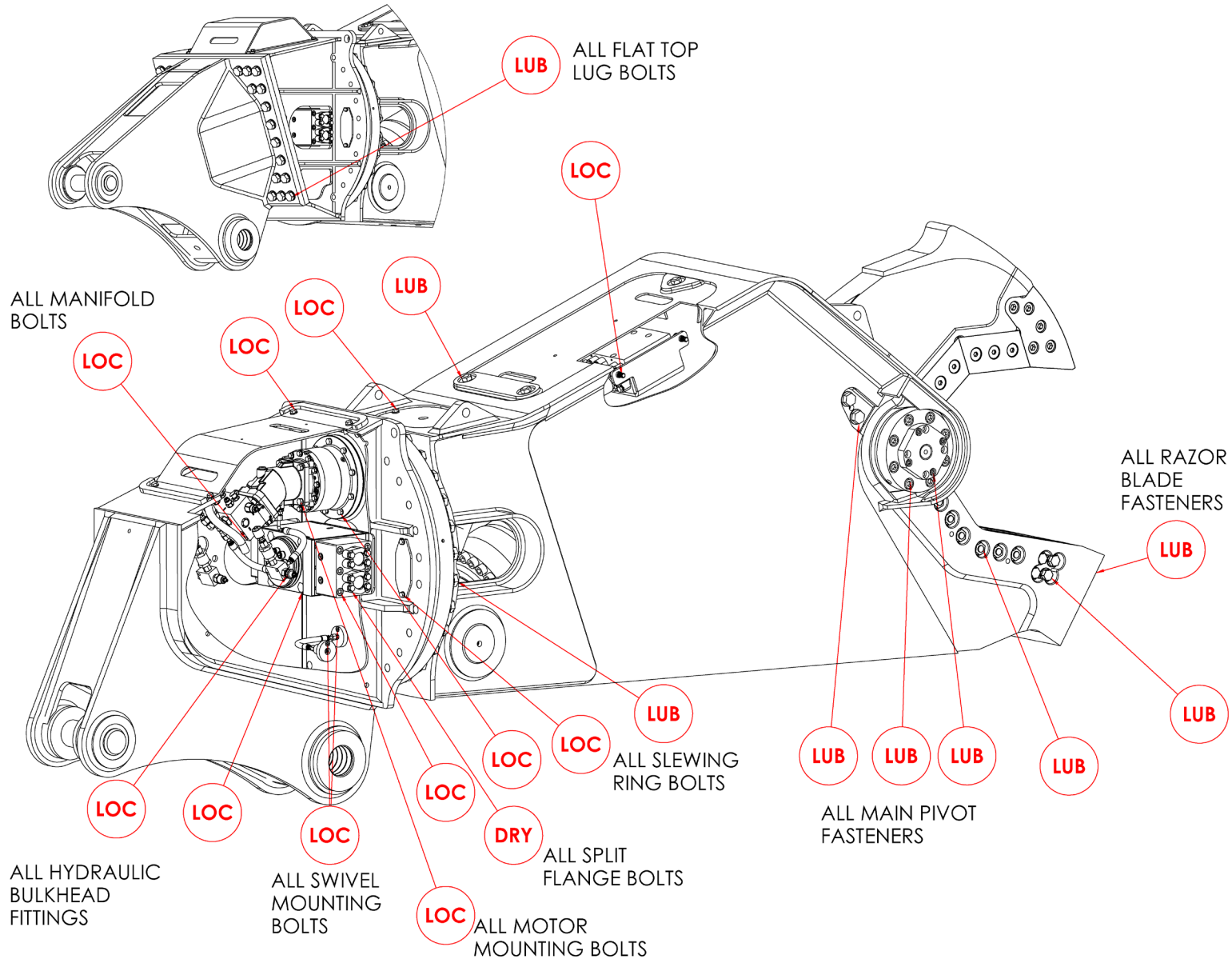

THREAD TREATMENT DIAGRAM

GRX, GDT, GDR & LXP® Demolition Tools

Use this diagram to determine what thread treatment, if any, is required for each fastener.

For thread treatment application procedures, see page 6. For prescribed torque values, see page 14.

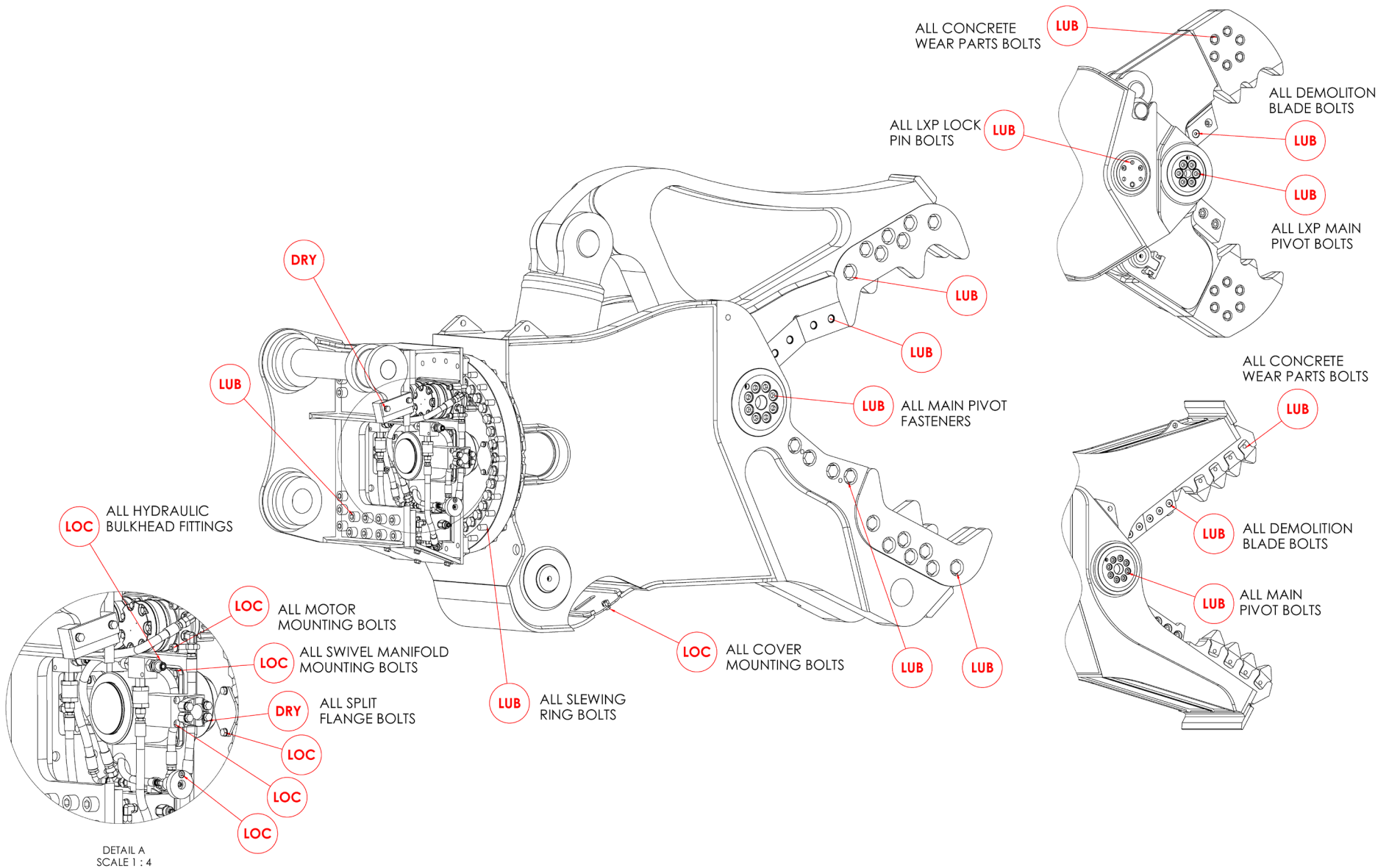

THREAD TREATMENT DIAGRAM

GCP Concrete Processor

Use this diagram to determine what thread treatment, if any, is required for each fastener.

For thread treatment application procedures, see page 6. For prescribed torque values, see page 14.

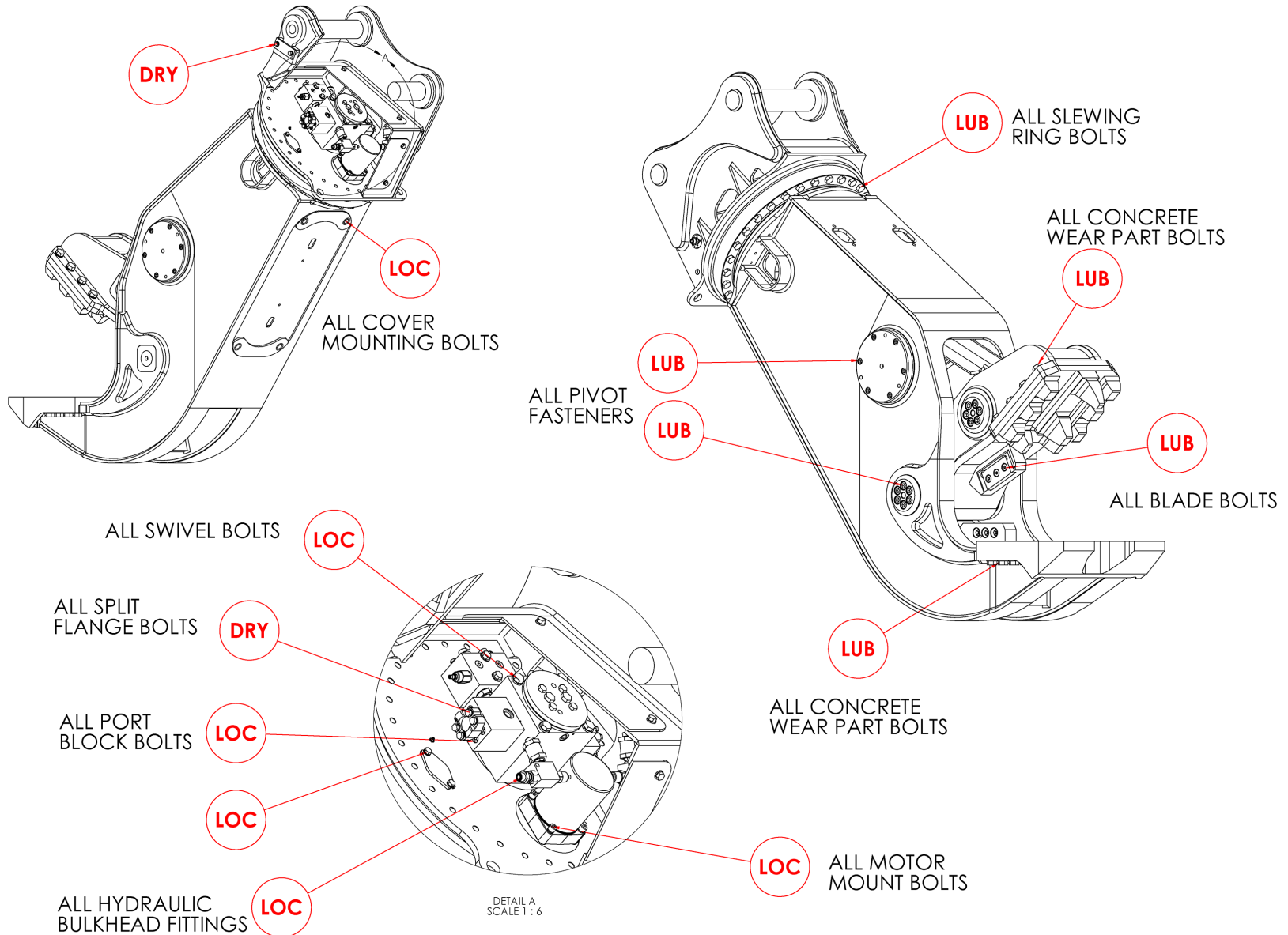

THREAD TREATMENT DIAGRAM

GMP, GMP C, GMP D, GSD, GRS, GLS & GCC Linkage Tools

Use this diagram to determine what thread treatment, if any, is required for each fastener.

For thread treatment application procedures, see page 6. For prescribed torque values, see page 14.

ALL PULVERIZER AND
CRACKER CONCRETE
WEAR PARTS BOLTS

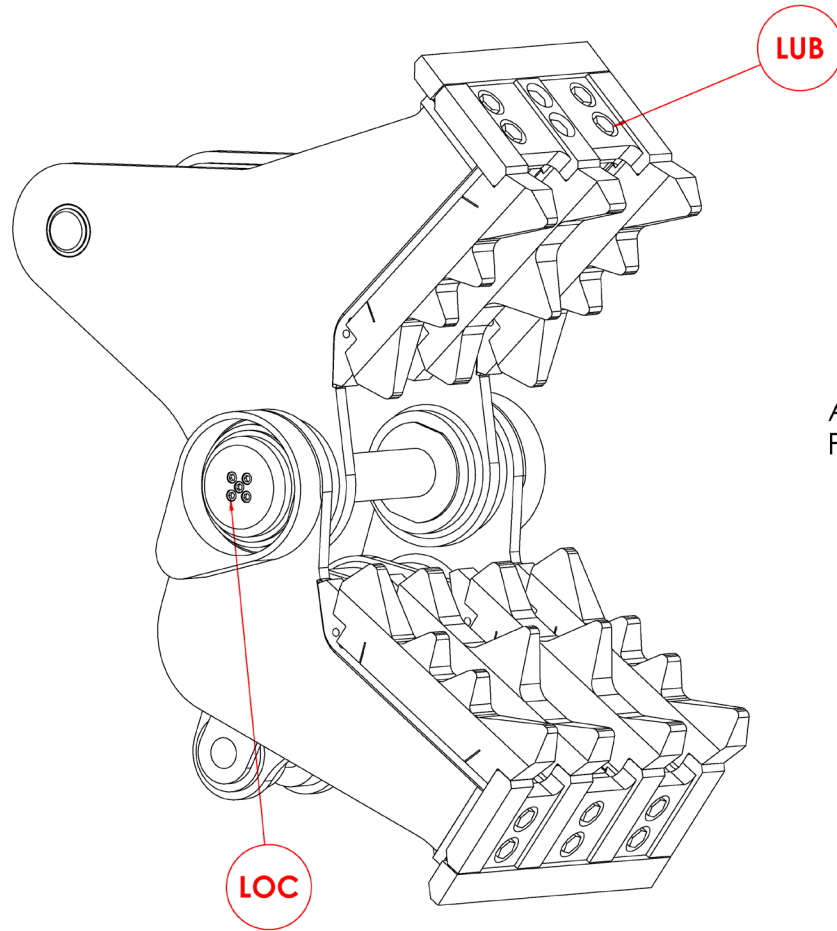

ALL PIVOT
FASTENERS

ALL PIVOT
FASTENERS

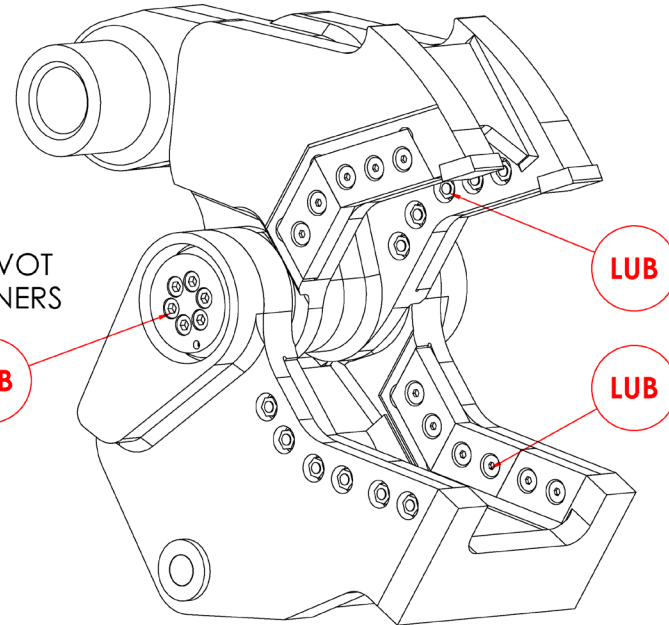

ALL LINKAGE
ATTACHMENT
BLADE BOLTS
(LUBE NUT AND
BOLT THREADS)

THREAD TREATMENT DIAGRAM

GHG & GSG Grapples

Use this diagram to determine what thread treatment, if any, is required for each fastener.

For thread treatment application procedures, see page 6. For prescribed torque values, see page 14.

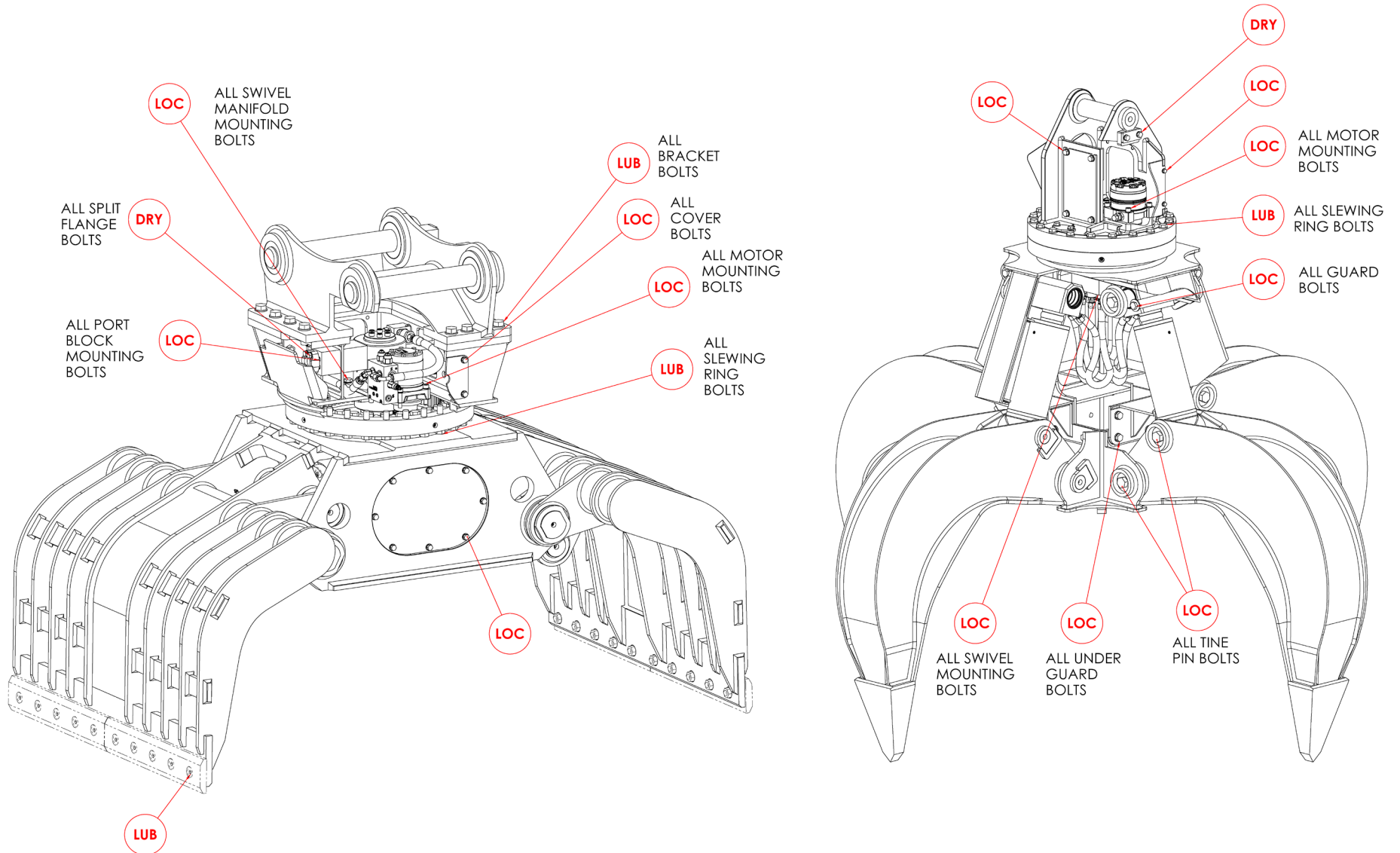

BOLT TORQUE SPECIFICATIONS

Reference the product Thread Treatment Diagrams beginning on page 8 to determine whether to use wet or dry torque values for specific bolts.

Reference Procedures on page 6 for threadlocker or anti-seize application and bolt and bolt hole cleaning.

Prior to torquing, clean all bolt holes, bolts and nuts to remove dirt, grease and oil, and identify bolt type.

Never re-torque bolts that use Loctite. If a bolt becomes loose or damaged after the initial use when Loctite was applied and the bolt was torqued, the bolt must be replaced.



Never break tightened bolts loose with a torque wrench. Doing so may break the torque wrench or take it out of calibration.



Torque wrenches should be calibrated on an annual basis.

When using a torque multiplier with a torque wrench, incorrect settings will be multiplied by the ratio of the torque wrench.

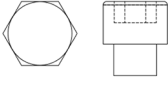
Never use an impact driver on a torque multiplier.

BOLT TORQUE SPECIFICATIONS

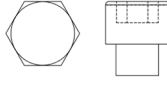
Dry Torque Values					
		Hex/Socket Head		Flat Head	
					
Fastener Grade	Size x Pitch	Nm	Ft-lb	Nm	Ft-lb
CL 10.9	M8 x 1.25	35	26	27	20
	M10 x 1.50	71	53	58	42
	M12 x 1.75	124	92	101	73
	M14 x 1.50	200	148	163	118
	M14 x 2.00	200	148	163	118
	M16 x 2.00	311	230	254	184
	M20 x 1.50	610	450	498	360
	M20 x 2.50	608	449	497	359
	M24 x 3.00	1054	778	861	622
	M27 x 3.00	1543	1138	1260	910
	M30 x 3.50	2095	1545	1712	1236
	M36 x 4.00	3659	2699	2991	2159
8	1/4-20	14	11	11	8
	5/16-18	32	24	26	19
	3/8-16	59	44	48	35
	7/16-14	94	70	77	56
	1/2-13	143	106	116	84
	1/2-20	162	120	133	96
	5/8-11	287	212	234	169
	3/4-10	509	376	415	300
	7/8-9	821	606	670	484
	1.00-8	1232	909	1007	727
	1.00-14	1383	1020	1130	816
	1.25-7	2463	1817	2013	1453
L9	1.50-6	4287	3162	3504	2529

Wet Torque Values					
		Hex/Socket Head		Flat Head	
					
Fastener Grade	Size x Pitch	Nm	Ft-lb	Nm	Ft-lb
CL 10.9	M8 x 1.25	29	22	23	17
	M10 x 1.50	61	45	49	36
	M12 x 1.75	105	78	85	62
	M14 x 1.50	150	111	121	88
	M14 x 2.00	170	126	138	100
	M16 x 2.00	265	196	216	156
	M20 x 1.50	456	337	372	269
	M20 x 2.50	517	382	422	305
	M24 x 3.00	894	660	731	528
	M27 x 3.00	1312	968	1072	774
	M30 x 3.50	1779	1312	1453	1049
	M36 x 4.00	3110	2294	2542	1835
8	1/4-20	13	10	11	8
	5/16-18	27	20	22	16
	3/8-16	50	37	40	29
	7/16-14	80	59	65	47
	1/2-13	122	90	99	72
	1/2-20	138	102	112	81
	5/8-11	244	180	199	144
	3/4-10	433	320	354	256
	7/8-9	698	515	570	412
	1.00-8	1046	772	854	617
	1.00-14	1175	867	960	693
	1.25-7	2095	1545	1712	1236
L9	1.50-6	3644	2688	2979	2150

O-RING BOSS & FLAT FACE O-RING TORQUE SPECIFICATIONS

O-Ring Boss Torque Values		
Size Dash	Nm	Ft-lb
-4	22	16
-5	27	20
-6	36	26
-8	83	60
-10	110	80
-12	187	135
-14	249	180
-16	304	220
-20	387	280
-24	498	360

Flat Face O-Ring Torque Values		
Size Dash	Nm	Ft-lb
-4	18	13
-6	30	22
-8	60	44
-10	85	62
-12	121	88
-14	121	88
-16	160	116
-20	213	154
-24	274	198

BOLT DRIVE SPECIFICATIONS

Thread Size x Pitch	Hex Head	Socket Head	Flat Head
			
Wrench/Drive Size			
M8 x 1.25	13mm	6mm	5mm
M10 x 1.50	17mm	8mm	6mm
M12 x 1.75	19mm	10mm	8mm
M14 x 1.50	22mm	12mm	10mm
M14 x 2.00	22mm	12mm	10mm
M16 x 2.00	24mm	14mm	10mm
M20 x 1.50	30mm	17mm	12mm
M20 x 2.50	30mm	17mm	12mm
M24 x 3.00	36mm	19mm	14mm
M27 x 3.00	41mm	19mm	-
M30 x 3.50	46mm	22mm	-
M36 x 4.00	55mm	27mm	-
1/4-20	7/16"	3/16"	5/32"
5/16-18	1/2"	1/4"	3/16"
3/8-16	9/16"	5/16"	7/32"
7/16-14	5/8"	3/8"	1/4"
1/2-13	3/4"	3/8"	5/16"
1/2-20	3/4"	3/8"	5/16"
5/8-11	15/16"	1/2"	3/8"
3/4-10	1-1/8"	5/8"	1/2"
7/8-9	1-5/16"	3/4"	9/16"
1.00-8	1-1/2"	3/4"	5/8"
1.00-14	1-1/2"	3/4"	5/8"
1.25-7	1-7/8"	7/8"	7/8"
1.50-6	2-1/4"	1"	1"



GENESIS®

The Promise of Performance.

CONTACT INFORMATION

Genesis Attachments

1000 Genesis Drive
Superior, WI 54880 USA

Toll Free: 888-SHEAR-IT
(888-743-2748)

Phone: 715.395.5252

E-mail:
info@genesisattachments.com

Europe/Africa/Middle East Genesis GmbH

Teramostrasse 23
87700 Memmingen, Germany

Phone: +49 83 31 9 25 98 0

Fax: +49 83 31 9 25 98 80

genesis-europe.com

E-mail:
info@genesis-europe.com

Asia Pacific Representative Office

24 Upper Serangoon View #12-28
Singapore 534205

Phone: +65 9673 9730

E-mail:
tchoo@genesisattachments.com

Central America & Colombia

Cra 13A #89-38 / Ofi 613
Bogota, Colombia

Phone: +57 1 610 8160 / 795 8747

E-mail:
contact@themsagroup.com

View and download all manuals: genesisattachments.com/manuals

Patents: genesisattachments.com/products/patents