

GENESIS[®]

The Promise of Performance.

M7 Concrete Cracker

PARTS MANUAL



CONTACT INFORMATION

Genesis Attachments

1000 Genesis Drive
Superior, WI 54880 USA

Toll Free: 888-SHEAR-IT
(888-743-2748)

Phone: 715.395.5252

E-mail:
info@genesisattachments.com

Europe/Africa/Middle East Genesis GmbH

Teramostrasse 23
87700 Memmingen, Germany

Phone: +49 83 31 9 25 98 0
Fax: +49 83 31 9 25 98 80
genesis-europe.com

E-mail:
info@genesis-europe.com

Asia Pacific Representative Office

24 Upper Serangoon View #12-28
Singapore 534205

Phone: +65 9673 9730

E-mail:
tchoo@genesisattachments.com

Central America & Colombia

Cra 13A #89-38 / Ofi 613
Bogota, Colombia

Phone: +57 1 610 8160 / 795 8747

E-mail:
contact@themsagroup.com

View and download all manuals: [genesisattachments.com/manuals](https://www.genesisattachments.com/manuals)
Patents: [genesisattachments.com/products/patents](https://www.genesisattachments.com/products/patents)

TABLE OF CONTENTS

CONTACT INFORMATION	2
GENERAL ARRANGEMENT	4
ASSEMBLY PIVOT GROUP	6
ASSEMBLY BLADE KIT	8
ASSEMBLY CYLINDER & PINS	10
ASSEMBLY BROKK[®] SUB-HEAD	12
ASSEMBLY THIRD-MEMBER SUB-HEAD	14
ASSEMBLY CONCRETE JAWS	16
ASSEMBLY HOSES & CYLINDER BLOCKS	18
ASSEMBLY ROTATION BRAKE	20
ASSEMBLY HYDRAULIC BOOSTER	22
ASSEMBLY FRAME & ACCESS COVERS	24
ASSEMBLY SWIVEL MANIFOLD	26
BOLT TORQUE SPECIFICATIONS	28
THREAD TREATMENT DIAGRAM	29
PROCEDURES	30
Cleaning	30
Threadlocker	30
Anti-Seize	31
No Thread Treatment	31
BOLT TORQUE SPECIFICATIONS	32
Dry Torque Values	32
Wet Torque Values	32
O-RING BOSS & FLAT FACE O-RING TORQUE SPECIFICATIONS	33
BOLT DRIVE SPECIFICATIONS	34
WARRANTY	35
Claim Procedure	35
Blade Warranty	35
PARTS ORDER POLICY AND PROCEDURE	36
Parts Orders Should Include	36
Placing Orders	36
Part Numbers	36
Shipping	36
Invoices	36
Returns	36
Warranty Returns	36
PARTS ORDER FORM	37
INDEX	38
CONTACT INFORMATION	40

GENERAL ARRANGEMENT

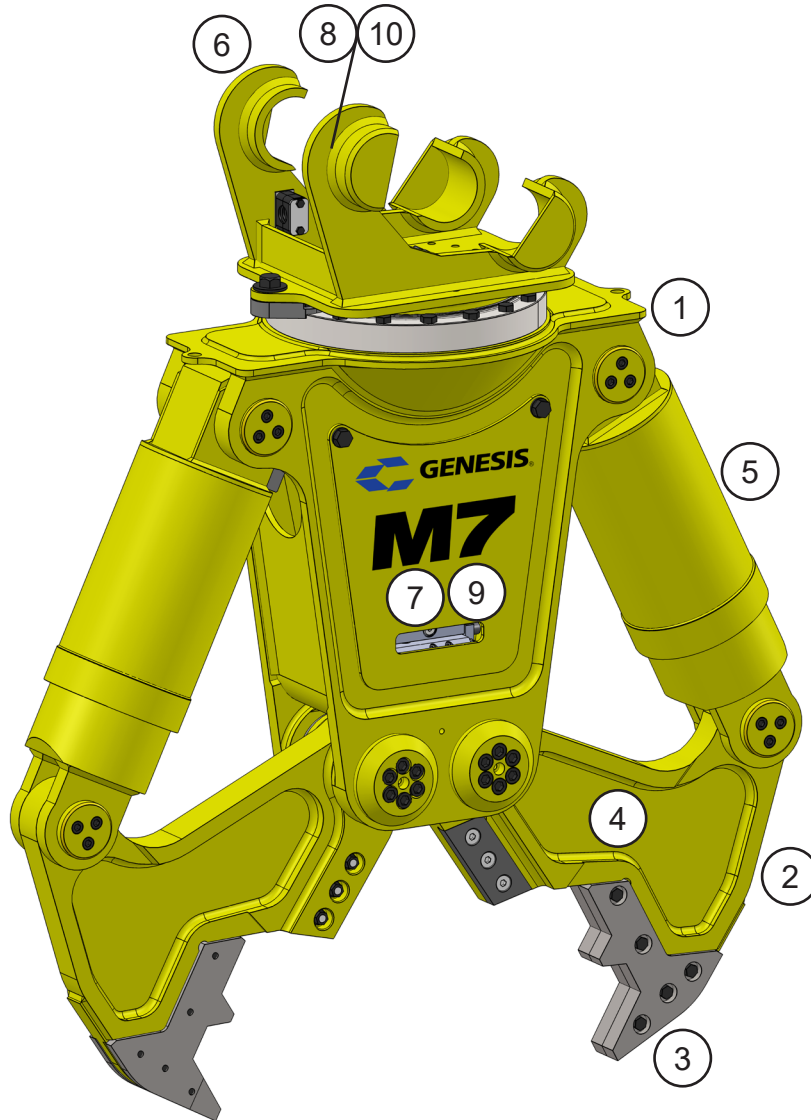

GENERAL ARRANGEMENT

ITEM	QTY	PART NUMBER	DESCRIPTION
1		See page 24	Assembly Frame and Access Covers
2		See page 16	Assembly Concrete Jaw
3		See page 8	Assembly Blade Kit
4		See page 6	Assembly Pivot Group
5		See page 10	Assembly Cylinder and Pins
6		See page 12	Assembly Brokk [®] Sub-Head
7		See page 18	Assembly Hoses and Cylinder Blocks
8		See page 20	Assembly Rotation Brake
9		See page 22	Assembly Hydraulic Booster
10		See page 26	Assembly Swivel Manifold

ASSEMBLY PIVOT GROUP

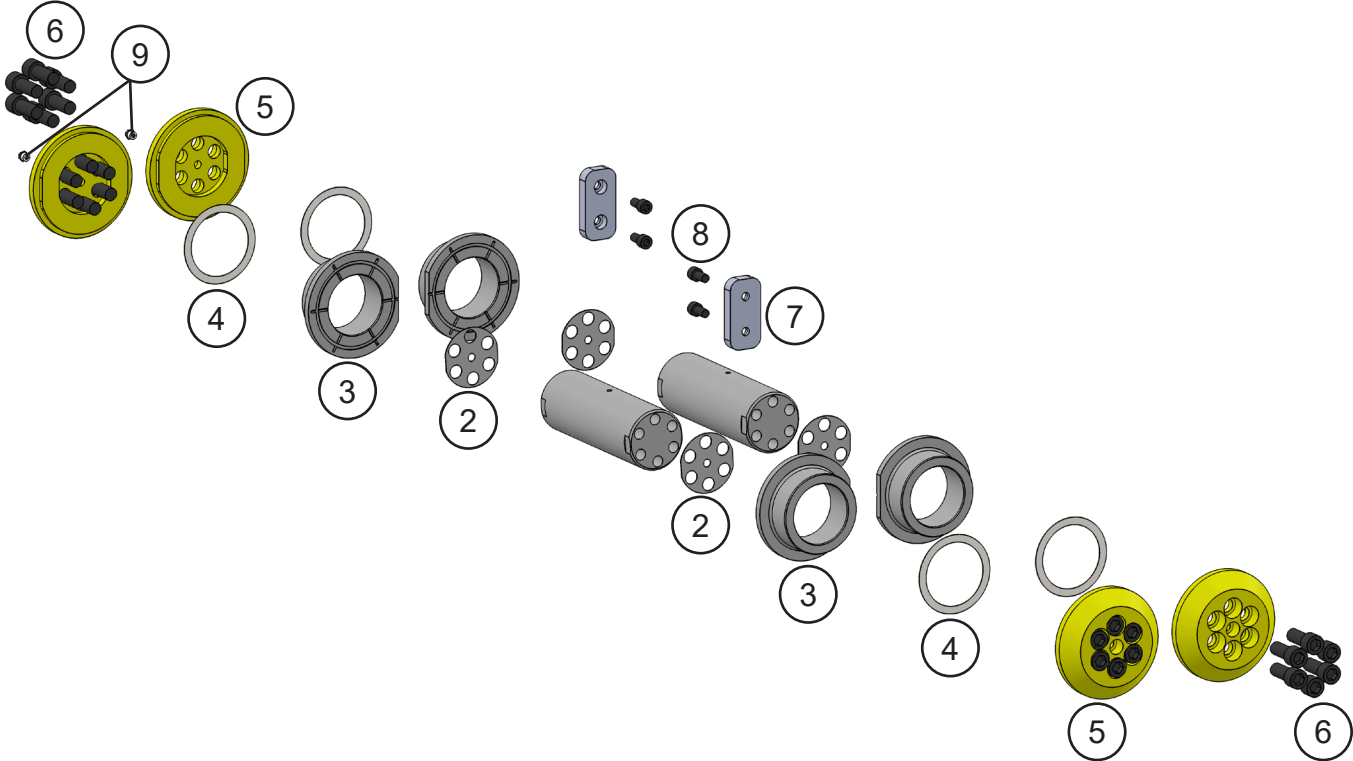

ASSEMBLY PIVOT GROUP

ITEM	QTY	PART NUMBER	DESCRIPTION
1	2	3101286	Mach Main Shaft
2	4	3101281	Shim Set Main Shaft
3	4	3101280	Mach Flange Bushing
4	4	3500467	Shim Set Flange Bushing
5	4	3101287	Mach End Cap
6	24	F0616040	Socket Head Capscrew M16 x 2 x 40
7	2	3101290	Rotation Block
8	4	F0610020	Socket Head Capscrew M10 x 1.50 x 20
9	2	6200002	Grease Fitting

ASSEMBLY BLADE KIT

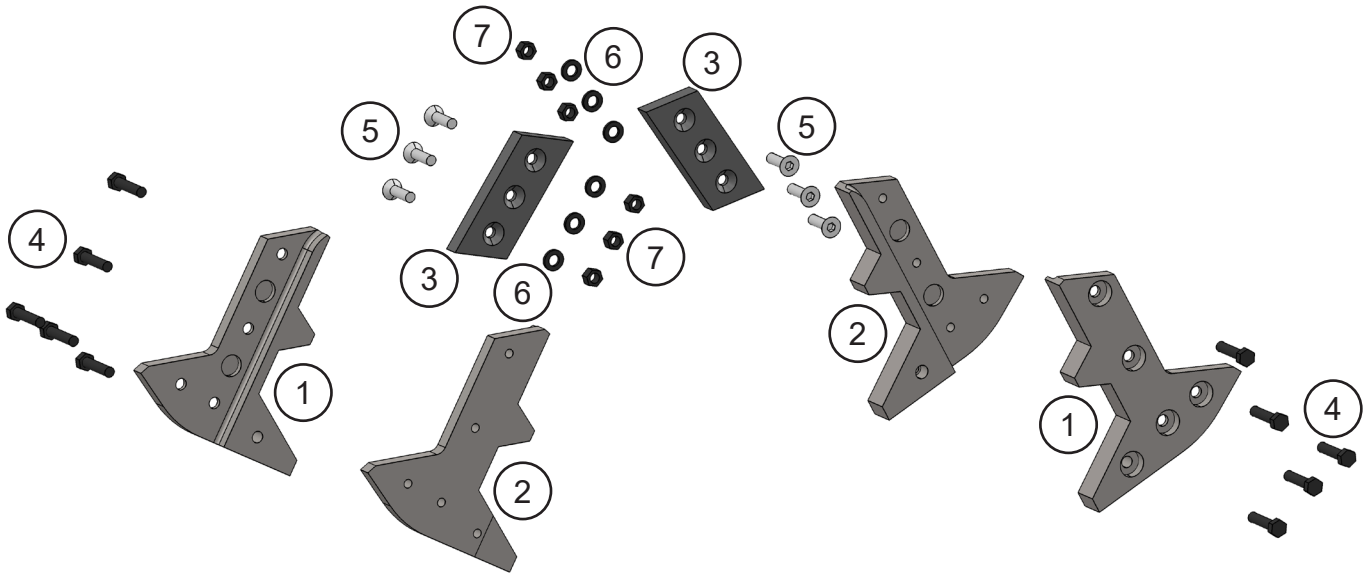

ASSEMBLY BLADE KIT

ITEM	QTY	PART NUMBER	DESCRIPTION
1	2	3101275	Mach Tooth C'bore
2	2	3101277	Mach Tooth Tapped
3	2	3101279	Mach Blade Ctsk
4	10	F0112050	Hex Head Bolt M12 x 1.75 x 50
5	6	F0412040	Flat Head Capscrew M12 x 1.75 x 40
6	6	F1201224	Flat Washer M12
7	6	F0812175	Hex Nut M12 x 1.75

ASSEMBLY CYLINDER AND PINS

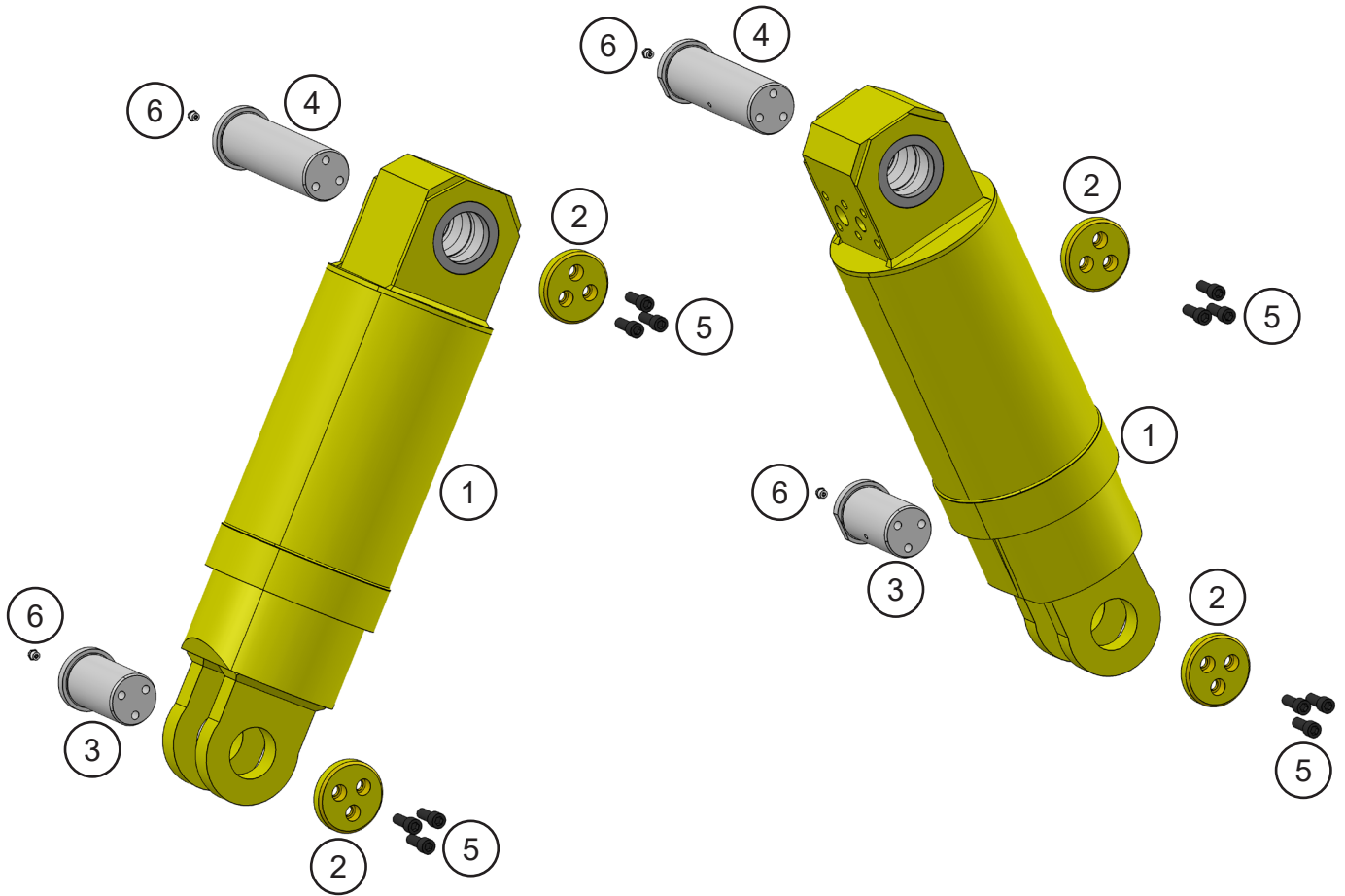

ASSEMBLY CYLINDER AND PINS

ITEM	QTY	PART NUMBER	DESCRIPTION
1	2	6350176	Cylinder
2	4	3101272	Mach End Cap Pin
3	2	3101268	Mach Pin 2.50 x 4.468
4	2	3101269	Mach Pin 2.50 x 8.097
5	12	F0612030	Socket Head Capscrew M12 x 1.75 x 30
6	4	6200002	Grease Fitting

ASSEMBLY BROKK® SUB-HEAD

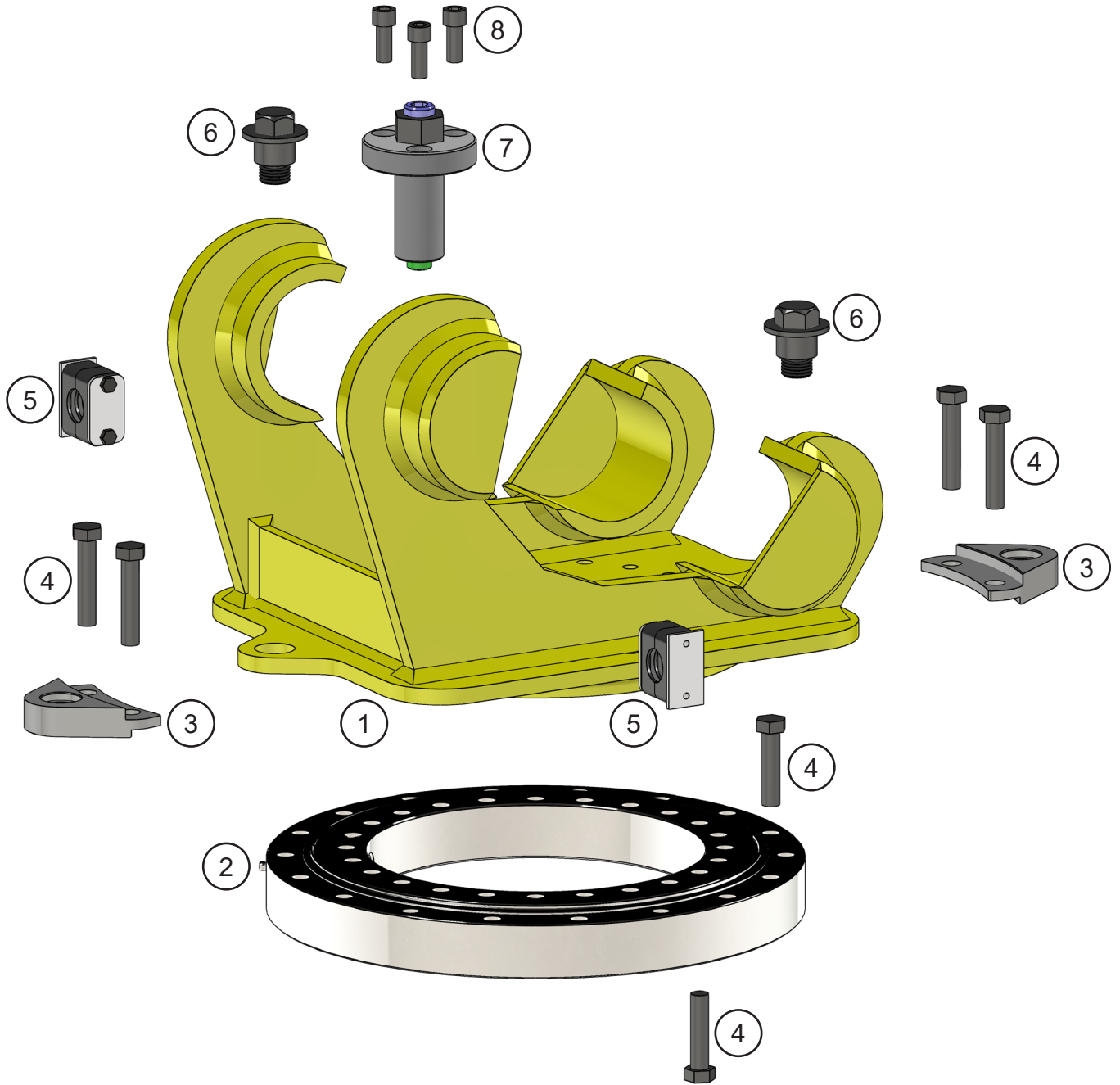

ASSEMBLY BROKK® SUB-HEAD

ITEM	QTY	PART NUMBER	DESCRIPTION
1	1	5518487	Brokk® Subhead
2	1	6302672	Slewing Ring
3	2	3101298	Mach Rotation Lock
4	40	F0114070	Hex Head Capscrew M14 x 2 x 70
5	2	6370006	Hose Clamp
6	2	3101300	Mach Shoulder Bolt
7	1	3101303	Assy Brake
8	3	F0612030	Socket Head Capscrew M12 x 1.75 x 30

ASSEMBLY THIRD-MEMBER SUB-HEAD

This sub-head is not shown in the General Arrangement on page 4.

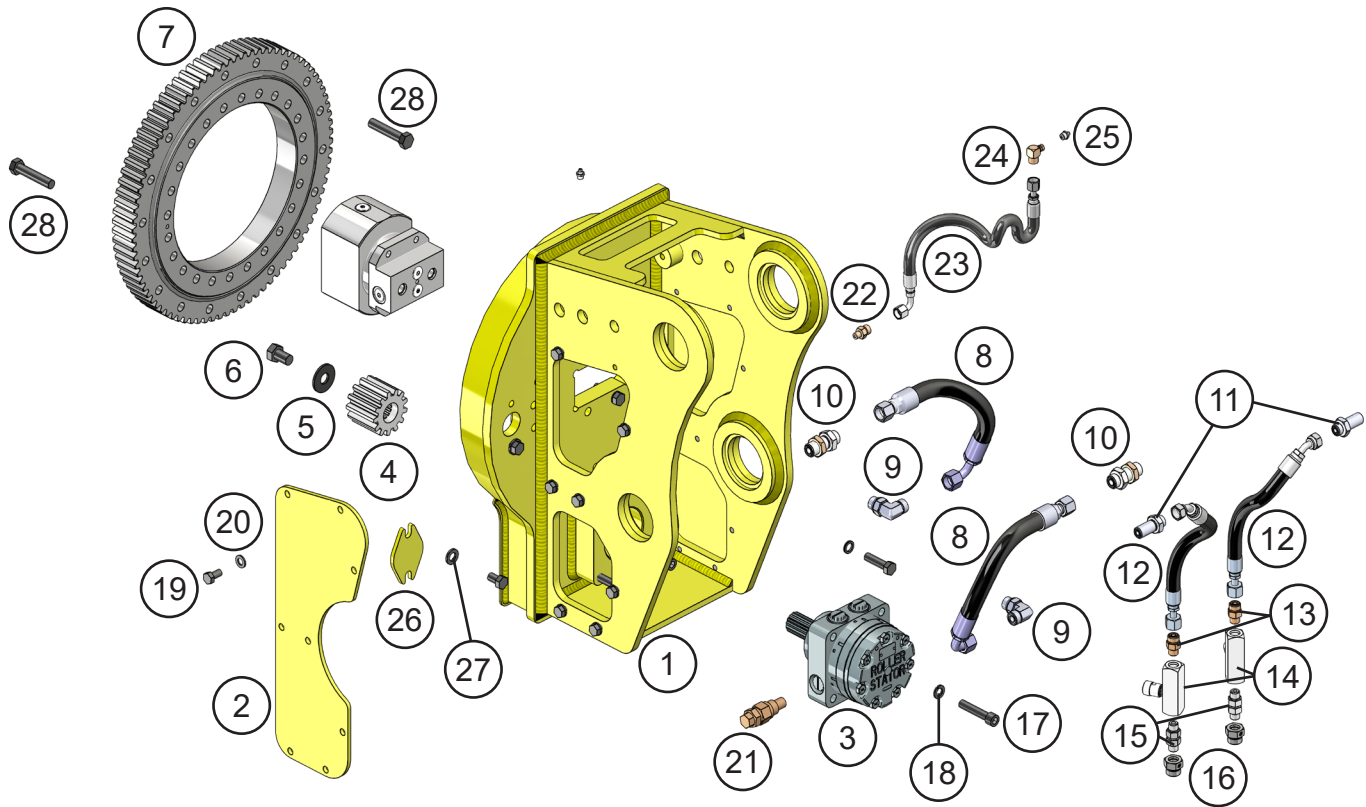

ASSEMBLY THIRD-MEMBER SUB-HEAD

ITEM	QTY	PART NUMBER	DESCRIPTION
1	1	5518700	Mach Sub-head
2	2	5518712	Side Cover
3	1	6340015	Motor
4	1	6300901	Pinion
5	1	F1310058	Flat Washer Wide
6	1	F0263100	Hex Head Capscrew $\frac{5}{8}$ x 18 x 1
7	1	6300878	Slewing Ring
8	2	3101327	Hose
9	2	6310379	Hydraulic Adapter
10	2	6300150	Adapter
11	2	6310149	Adapter
12	2	3101328	Hose
13	2	6300018	Adapter
14	2	6360038	Flow Controls
15	2	6310152	Adapter
16	2	6310382	Adapter
17	4	F0612060	Socket Head Capscrew M12 x 1.75 x 60
18	4	F1401200	Lock Washer M12
19	20	F0110020	Hex Head Capscrew M10 x 1.5 x 20
20	16	F1201021	Flat Washer M10
21	1	6300902	Valve Cross-port Relief
22	1	6300731	Adapter
23	1	5300208	Hose
24	1	6300405	Adapter
25	2	6200002	Grease Fitting
26	2	2200510	Bolt Cover
27	4	F1201224	Flat Washer M12
28	40	F0114070	Hex Head Capscrew M14 x 2 x 70

ASSEMBLY CONCRETE JAW

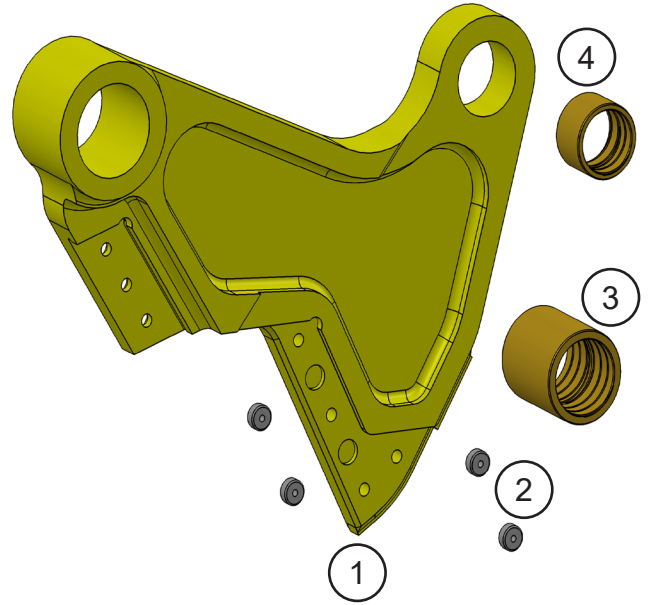
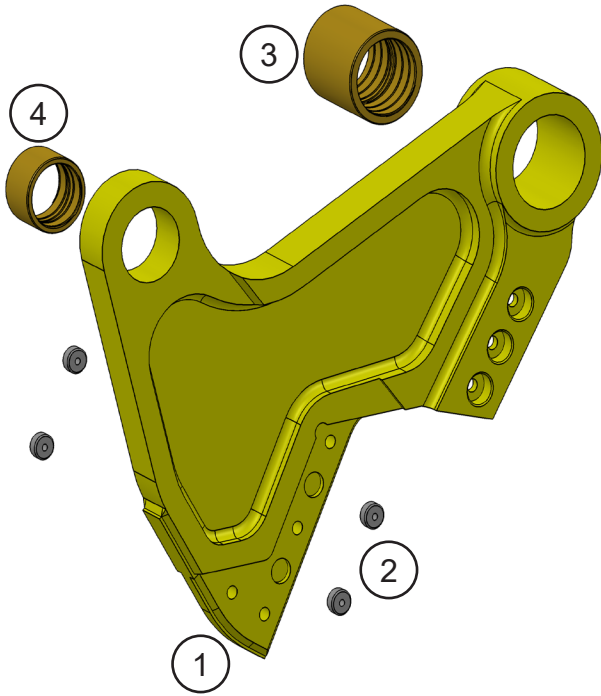

ASSEMBLY CONCRETE JAW

ITEM	QTY	PART NUMBER	DESCRIPTION
1	2	3101316	Mach Cracker Jaw
2	8	3101278	Retaining Puck
3	2	3101289	Jaw Main Bearing
4	2	3101274	Jaw Cylinder Bearing

ASSEMBLY HOSES AND CYLINDER BLOCKS

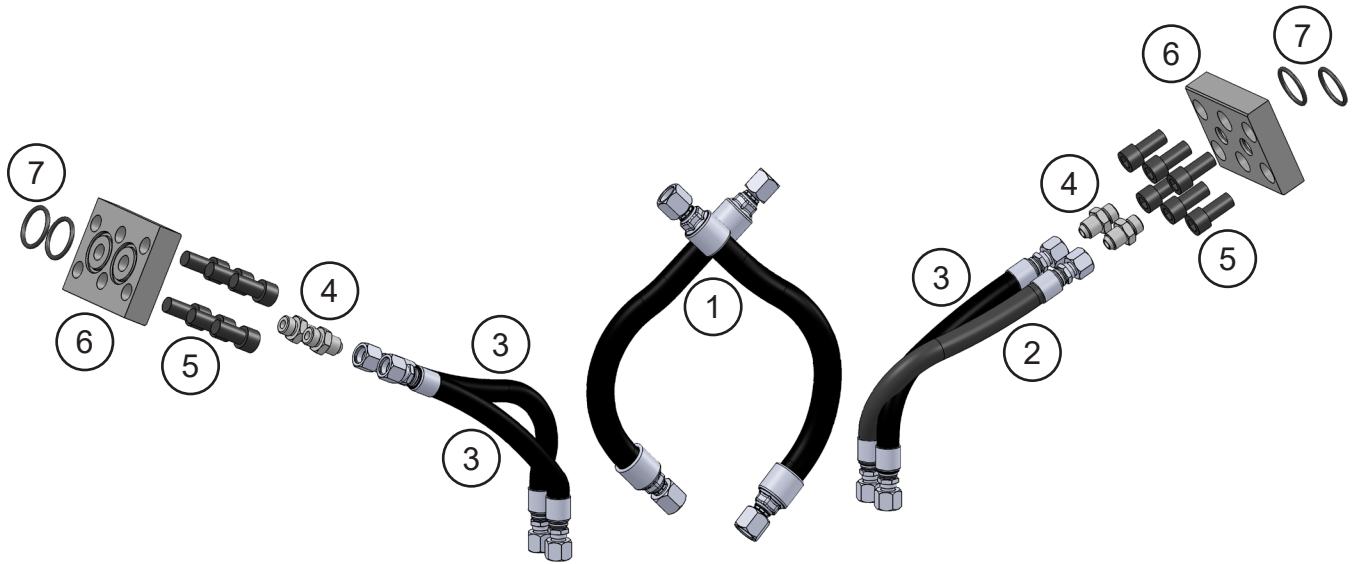

ASSEMBLY HOSES AND CYLINDER BLOCKS

ITEM	QTY	PART NUMBER	DESCRIPTION
1	2	3101322	Hose
2	1	3101323	Hose
3	3	3101337	Hose
4	4	6302670	Adapter
5	12	F0614030	Socket Head Capscrew M14 x 2 x 30
6	2	3101296	Cylinder Port Block
7	4	S0190219	O-Ring

ASSEMBLY ROTATION BRAKE

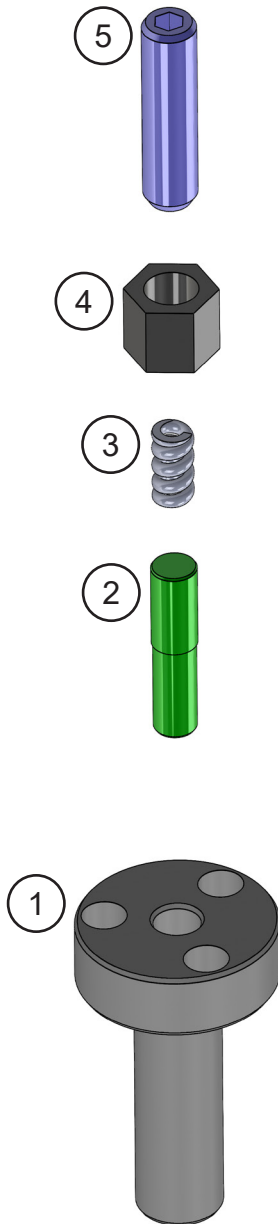

ASSEMBLY ROTATION BRAKE

ITEM	QTY	PART NUMBER	DESCRIPTION
1	1	3101301	Brake Hub
2	1	3101302	Brake Plunger
3	1	6200090	Spring
4	1	F0824300	Hex Nut M24 x 3
5	1	F2524080	Set Screw M24 x 3

ASSEMBLY HYDRAULIC BOOSTER

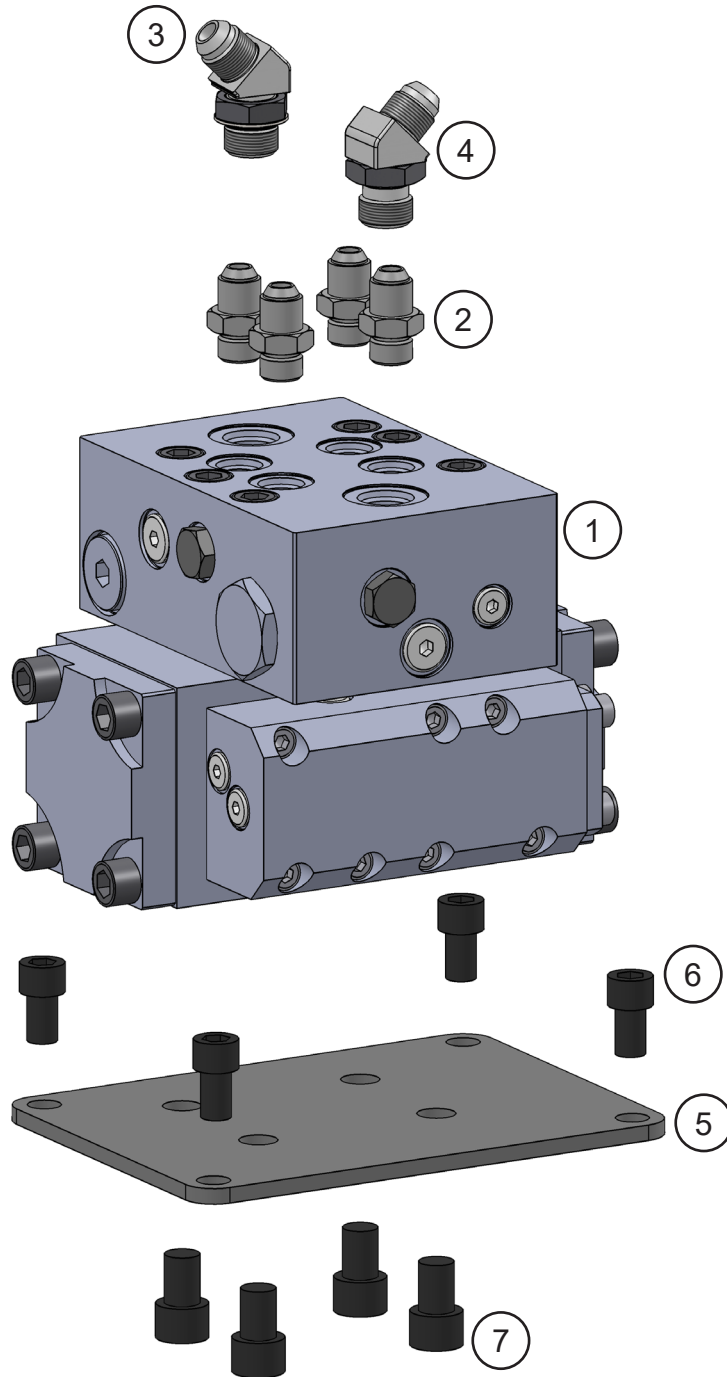

ASSEMBLY HYDRAULIC BOOSTER

ITEM	QTY	PART NUMBER	DESCRIPTION
1	1	6360153	Booster Valve
2	4	6302670	Adapter
3	1	6302669	Adapter
4	1	6302668	Adapter
5	1	3101294	Booster Plate
6	4	F0612020	Socket Head Capscrew M12 x 1.75 x 20
7	4	F0614020	Socket Head Capscrew M14 x 2 x 20

ASSEMBLY FRAME AND ACCESS COVERS

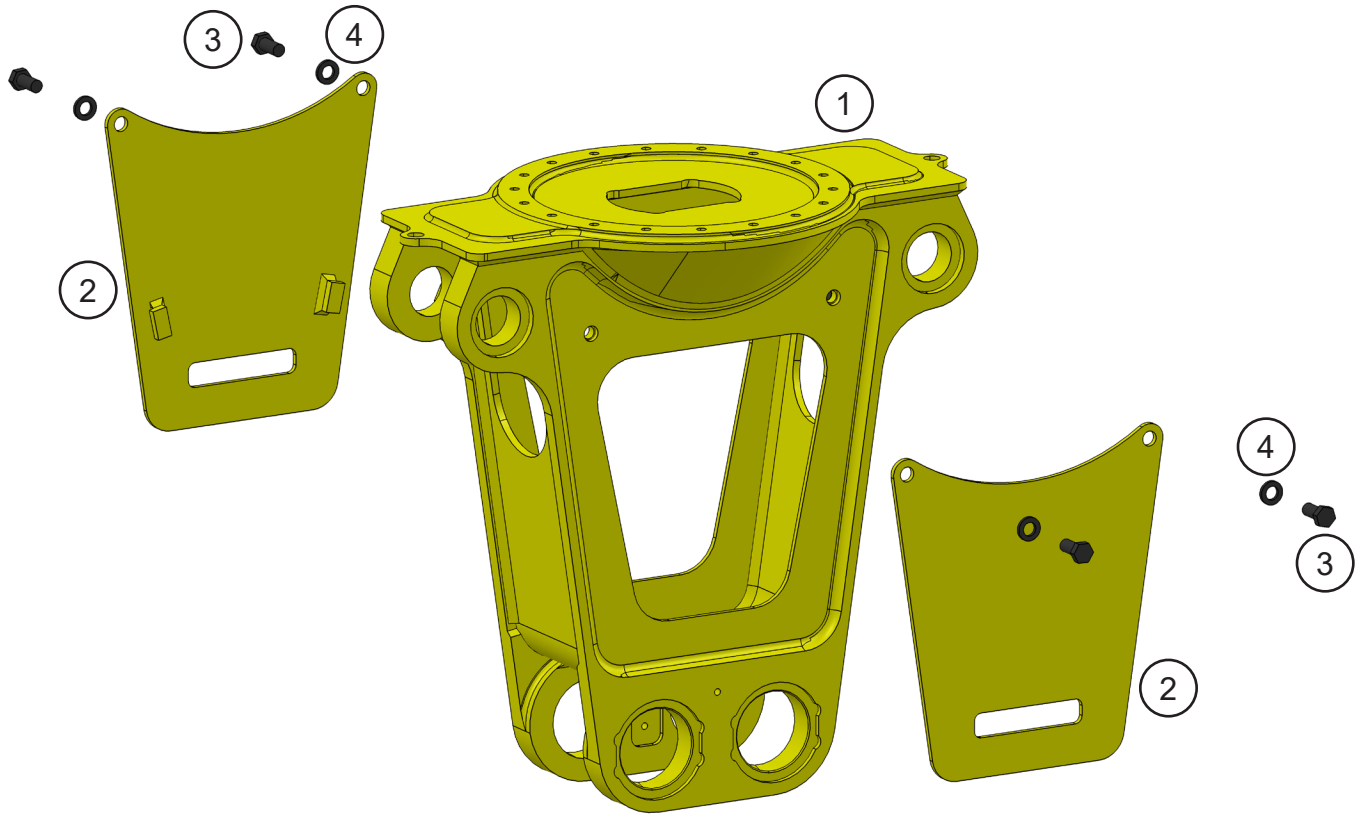

ASSEMBLY FRAME AND ACCESS COVERS

ITEM	QTY	PART NUMBER	DESCRIPTION
1	1	3101315	Mach Frame
2	2	3101304	Cover
3	4	F0116035	Hex Head Capscrew M16 x 2 x 35
4	4	F1201630	Flat Washer M16

ASSEMBLY SWIVEL MANIFOLD

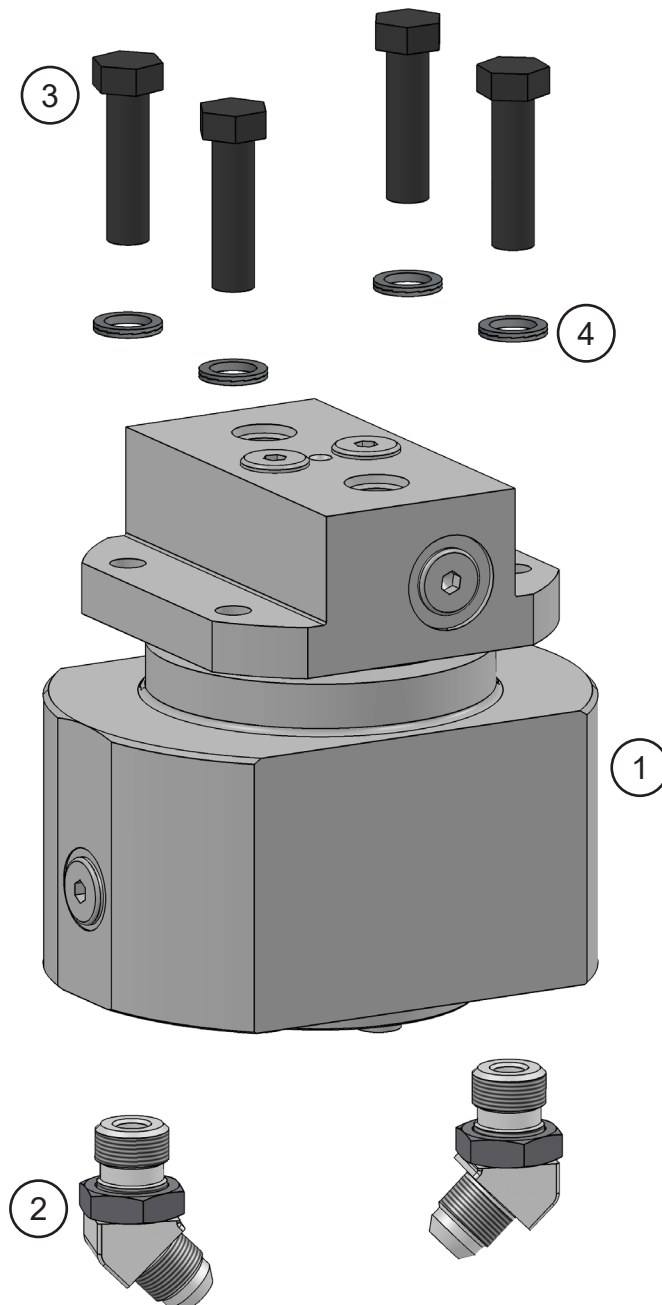

ASSEMBLY SWIVEL MANIFOLD

ITEM	QTY	PART NUMBER	DESCRIPTION
1	1	6350177	Swivel Manifold
2	2	6302668	Adapter
3	4	F0112045	Hex Head Capscrew M12 x 1.75 x 45
4	4	F1900050	Nord Lock Washer M12

BOLT TORQUE SPECIFICATIONS

Reference the product Thread Treatment Diagram on page 29 to determine whether to use wet or dry torque values for specific bolts.

Reference Procedures on page 30 for threadlocker or anti-seize application and bolt and bolt hole cleaning.

Prior to torquing, clean all bolt holes, bolts and nuts to remove dirt, grease and oil, and identify bolt type.

Never re-torque bolts that use Loctite. If a bolt becomes loose or damaged after the initial use when Loctite was applied and the bolt was torqued, the bolt must be replaced.

Never break tightened bolts loose with a torque wrench. Doing so may break the torque wrench or take it out of calibration.

Torque wrenches should be calibrated on an annual basis.

When using a torque multiplier with a torque wrench, incorrect settings will be multiplied by the ratio of the torque wrench.

Never use an impact driver on a torque multiplier.

THREAD TREATMENT DIAGRAM

Use this diagram to determine what thread treatment, if any, is required for each fastener.
For thread treatment application procedures, see page 30. For prescribed torque values, see page 32.

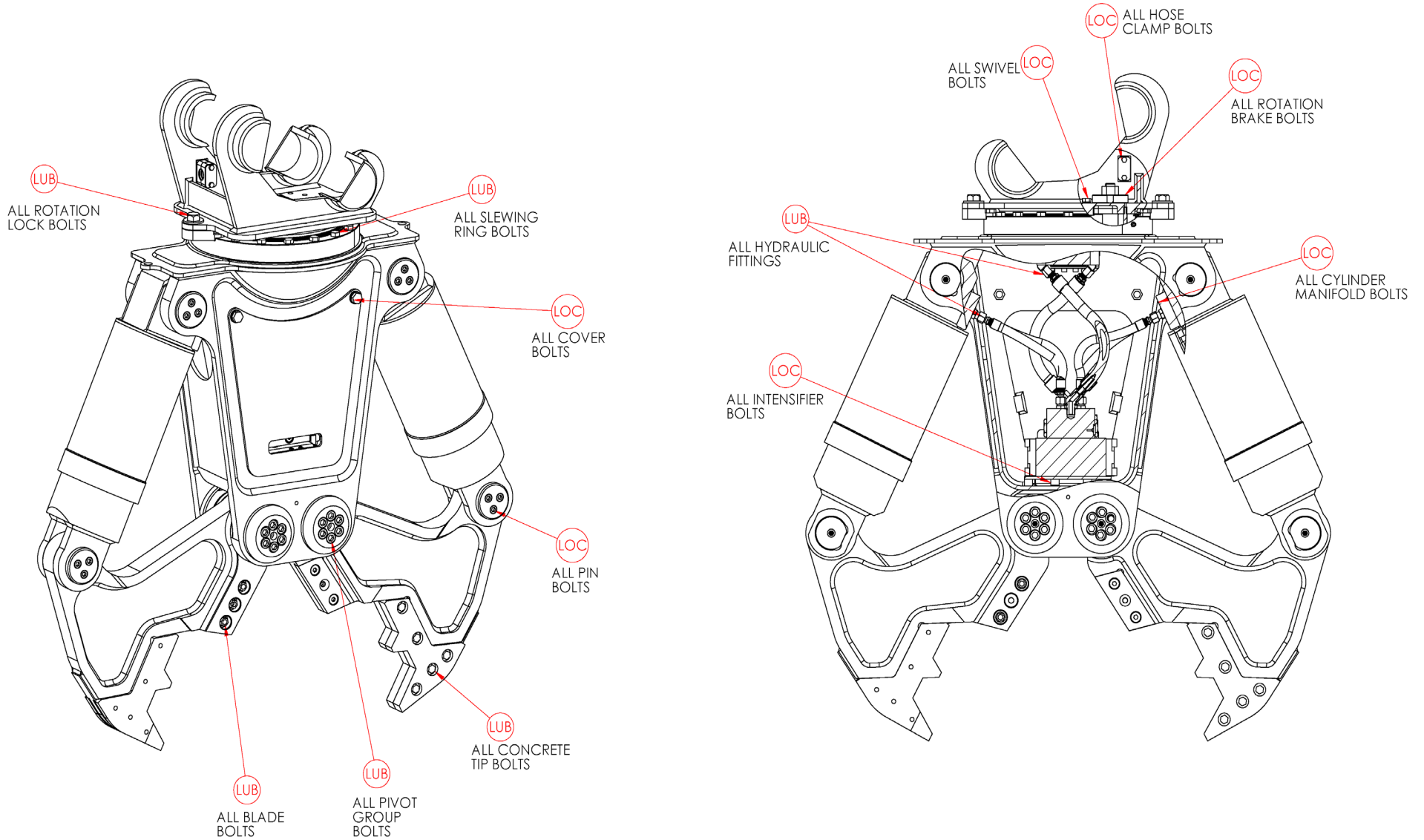

PROCEDURES

Reference the product Thread Treatment Diagram on page 29 to determine which of the following procedures is required.

Cleaning

To ensure proper performance of thread treatment and accurate torque values, clean and degrease **all internal and external threads** prior to application of threadlocker, anti-seize or primer and before installation of hardware.

- Ensure both internal and external threads are free of dirt or debris.
- Use brake cleaner or similar cleaning solvent on all threads to remove any grease or oil.
- Allow threads to dry.

NOTICE

Failure to properly clean threads will cause threadlocker, primer, and/or anti-seize to not properly cure!

LOC

Threadlocker

For bolted connections requiring threadlocker, use **Loctite 263** or equivalent applied using the following procedure:

- Clean and degrease all threads.
- For thru holes or nuts, apply threadlocker to bolt threads.
- For blind holes, apply stripe of threadlocker along the length of the hole (applying to the bolt can cause escaping air to remove threadlocker as the bolt is inserted).
- Torque bolt to specified **Wet Torque Value**, see page 32.

For threaded hydraulic fitting connections, use **Loctite 5452** or equivalent thread sealant in conjunction with **Loctite 7471** primer using the following procedure:

- Clean and degrease all threads.
- Apply Loctite 7471 primer to both external and internal threads and allow to dry.
- Apply threadlocker to 360 degrees of the threads on the male fitting, ensuring adequate coverage.
- Assemble fitting per directions in operator's manual.
- For O-ring boss and flat face O-ring connections, torque fittings to values specified on page 33.

Threadlocker

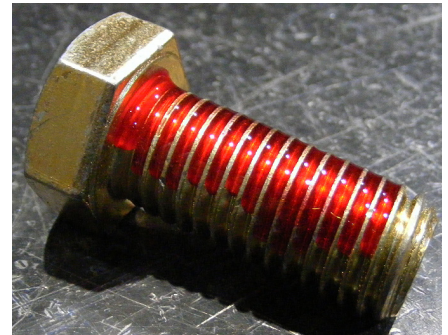

Blind Hole

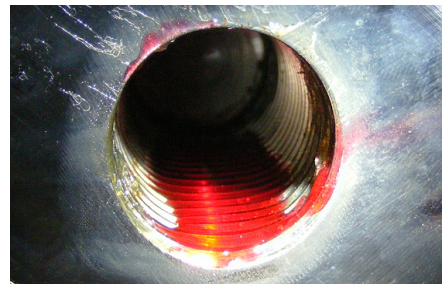

Hydraulic Fitting



PROCEDURES

LUB

Anti-Seize

For bolted connections requiring anti-seize lubrication, use **Loctite LB8008** or equivalent using the following procedure:

- Clean and degrease all threads.
- Apply thin coat of anti-seize to internal and external threads and under bolt head and/or nut, ensuring complete coverage.
- Torque bolt to specified **Wet Torque Value**, see page 32.

Anti-Seize









DRY

No Thread Treatment

- Clean and degrease all threads.
- Torque bolt to specified **Dry Torque Value**, see page 32.

BOLT TORQUE SPECIFICATIONS

Dry Torque Values					
		Hex/Socket Head		Flat Head	
		 			
Fastener Grade	Size x Pitch	Nm	Ft-lb	Nm	Ft-lb
CL 10.9	M8 x 1.25	35	26	27	20
	M10 x 1.50	71	53	58	42
	M12 x 1.75	124	92	101	73
	M14 x 1.50	200	148	163	118
	M14 x 2.00	200	148	163	118
	M16 x 2.00	311	230	254	184
	M20 x 1.50	610	450	498	360
	M20 x 2.50	608	449	497	359
	M24 x 3.00	1054	778	861	622
	M27 x 3.00	1543	1138	1260	910
	M30 x 3.50	2095	1545	1712	1236
	M36 x 4.00	3659	2699	2991	2159
8	1/4-20	14	11	11	8
	5/16-18	32	24	26	19
	3/8-16	59	44	48	35
	7/16-14	94	70	77	56
	1/2-13	143	106	116	84
	1/2-20	162	120	133	96
	5/8-11	287	212	234	169
	3/4-10	509	376	415	300
	7/8-9	821	606	670	484
	1.00-8	1232	909	1007	727
	1.00-14	1383	1020	1130	816
	1.25-7	2463	1817	2013	1453
8/L9	1.50-6	4287	3162	3504	2529

Wet Torque Values					
		Hex/Socket Head		Flat Head	
		 			
Fastener Grade	Size x Pitch	Nm	Ft-lb	Nm	Ft-lb
CL 10.9	M8 x 1.25	29	22	23	17
	M10 x 1.50	61	45	49	36
	M12 x 1.75	105	78	85	62
	M14 x 1.50	150	111	121	88
	M14 x 2.00	170	126	138	100
	M16 x 2.00	265	196	216	156
	M20 x 1.50	456	337	372	269
	M20 x 2.50	517	382	422	305
	M24 x 3.00	894	660	731	528
	M27 x 3.00	1312	968	1072	774
	M30 x 3.50	1779	1312	1453	1049
	M36 x 4.00	3110	2294	2542	1835
8	1/4-20	13	10	11	8
	5/16-18	27	20	22	16
	3/8-16	50	37	40	29
	7/16-14	80	59	65	47
	1/2-13	122	90	99	72
	1/2-20	138	102	112	81
	5/8-11	244	180	199	144
	3/4-10	433	320	354	256
	7/8-9	698	515	570	412
	1.00-8	1046	772	854	617
	1.00-14	1175	867	960	693
	1.25-7	2095	1545	1712	1236
8/L9	1.50-6	3644	2688	2979	2150

O-RING BOSS & FLAT FACE O-RING TORQUE SPECIFICATIONS

O-Ring Boss Torque Values		
Size Dash	Nm	Ft-lb
-4	22	16
-5	27	20
-6	36	26
-8	83	60
-10	110	80
-12	187	135
-14	249	180
-16	304	220
-20	387	280
-24	498	360

Flat Face O-Ring Torque Values		
Size Dash	Nm	Ft-lb
-4	18	13
-6	30	22
-8	60	44
-10	85	62
-12	121	88
-14	121	88
-16	160	116
-20	213	154
-24	274	198

BOLT DRIVE SPECIFICATIONS

Thread Size x Pitch	Hex Head	Socket Head	Flat Head
			
Wrench/Drive Size			
M8 x 1.25	13mm	6mm	5mm
M10 x 1.50	17mm	8mm	6mm
M12 x 1.75	19mm	10mm	8mm
M14 x 1.50	22mm	12mm	10mm
M14 x 2.00	22mm	12mm	10mm
M16 x 2.00	24mm	14mm	10mm
M20 x 1.50	30mm	17mm	12mm
M20 x 2.50	30mm	17mm	12mm
M24 x 3.00	36mm	19mm	14mm
M27 x 3.00	41mm	19mm	-
M30 x 3.50	46mm	22mm	-
M36 x 4.00	55mm	27mm	-
1/4-20	7/16"	3/16"	5/32"
5/16-18	1/2"	1/4"	3/16"
3/8-16	9/16"	5/16"	7/32"
7/16-14	5/8"	3/8"	1/4"
1/2-13	3/4"	3/8"	5/16"
1/2-20	3/4"	3/8"	5/16"
5/8-11	15/16"	1/2"	3/8"
3/4-10	1-1/8"	5/8"	1/2"
7/8-9	1-5/16"	3/4"	9/16"
1.00-8	1-1/2"	3/4"	5/8"
1.00-14	1-1/2"	3/4"	5/8"
1.25-7	1-7/8"	7/8"	7/8"
1.50-6	2-1/4"	1"	1"

WARRANTY

Claim Procedure

Notify the Genesis Service Department of the potential warranty claim prior to making the repair. Digital pictures are very helpful for diagnosing problems and recommending repairs.

Contact the Genesis Service Department before making alterations, changes or repairs to any component that is going to be considered for warranty. Not doing so will void all Genesis warranty consideration.

The Genesis Service Department will issue an authorization number to track the repair costs, outgoing parts, and/or defective parts returning to the factory.

Replacement parts must be ordered using a purchase order number. Shipping is standard ground. Overnight shipping is available by request, and Genesis will not cover the shipping charge.

When the repair is complete, submit an invoice to the Genesis Service Department within 30 days. Include itemized internal labor reporting, parts lists and invoices for outside contractors. Reference the authorization number on all invoices.

When returning parts for warranty consideration, include a copy of any related Genesis paperwork along with any other necessary documentation to ensure proper processing and credit. The Genesis Service Department will provide the necessary forms.

Your account will be credited when the warranty claim is accepted.

Blade Warranty

Standard warranty on blades will only be considered on the first edge, and wear on the edge must be 1/8" radius or less. Genesis does not warranty cutting blades that are cracked or broken from top to bottom (perpendicular to the long edge of the blade). Genesis also does not cover fasteners, the labor to replace wear components or collateral damage, such as blade seats, from broken blades, the piercing blade tang or adjustment plates.

Please direct any questions to the Genesis Service Department: 715-395-5252

PARTS ORDER POLICY AND PROCEDURE

Parts Orders Should Include

- Purchase order number
- Model and serial number of attachment
- Part number and quantity needed
- Shipping and billing address
- Method of shipment or required delivery date

Placing Orders

Orders may be placed by phone or e-mail. To e-mail an order, use the form on the following page or your purchase order form. Contact information is located at the front of this manual.

Part Numbers

Part numbers are listed in a separate Parts Manual or, if included, the Parts section of this manual. Contact the Genesis Parts Department with questions regarding part numbers, availability and pricing.

Shipping

All orders will be shipped best way surface unless an alternate shipping method is requested. Shipping charges are not included in the purchase price of parts.

Invoices

All invoices are due upon receipt. Any accounts with invoices open beyond 60 days are subject to review and may be placed on C.O.D. status without further notice.

Returns

Many unused Genesis parts may be returned with proper documentation. Return shipping is the responsibility of the purchaser. Credit will be issued upon return, less a 25% restocking fee. Documentation is required for credit of returned parts. Contact the Genesis Service Department at 715-395-5252 for an RGA (Return Goods Authorization) number and form. An RGA must accompany every return. Items shipped without an RGA may be returned to sender.

Warranty Returns

All parts returned to Genesis for warranty consideration must be returned with a completed RGA (Return Goods Authorization) provided by the Genesis Service Department. The form needs to be completed in its entirety, including any additional information requested by the Service Department. Return shipping is the responsibility of the sender and will be credited upon claim approval. A determination to accept or deny the claim will be made based upon the information available to Genesis. Warranty on purchased parts other than wear components is 6 months. Genesis does not cover labor costs to replace purchased parts replaced under warranty. There is no warranty period on wear parts or components.



PARTS ORDER FORM

Customer: _____

Date: _____

Phone: _____

Contact: _____

Shipping Address:

E-mail: _____

Billing Address:

Purchase Order: _____

Shipping Method: _____

Model: _____

Serial Number: _____

Quantity	Part Number	Description	Price

E-mail to the Genesis Parts Department: genesisparts@genesisattachments.com
For assistance, call 715-395-5252

INDEX

- 2200510 Bolt Cover 15
- 3101268 Mach Pin 2.50 x 4.468 11
- 3101269 Mach Pin 2.50 x 8.097 11
- 3101272 Mach End Cap Pin 11
- 3101274 Jaw Cylinder Bearing 17
- 3101275 Mach Tooth C'bore 9
- 3101277 Mach Tooth Tapped 9
- 3101278 Retaining Puck 17
- 3101279 Mach Blade Ctsk 9
- 3101280 Mach Flange Bushing 7
- 3101281 Shim Set Main Shaft 7
- 3101286 Mach Main Shaft 7
- 3101287 Mach End Cap 7
- 3101289 Jaw Main Bearing 17
- 3101290 Rotation Block 7
- 3101294 Booster Plate 23
- 3101296 Cylinder Port Block 19
- 3101298 Mach Rotation Lock 13
- 3101300 Mach Shoulder Bolt 13
- 3101301 Brake Hub 21
- 3101302 Brake Plunger 21
- 3101303 Assy Brake 13
- 3101304 Cover 25
- 3101315 Mach Frame 25
- 3101316 Mach Cracker Jaw 17
- 3101322 Hose 19
- 3101323 Hose 19
- 3101327 Hose 15
- 3101328 Hose 15
- 3101337 Hose 19
- 3500467 Shim Set Flange Bushing 7
- 5300208 Hose 15
- 5518487 Brokk Subhead 13
- 5518700 Mach Sub-head 15
- 5518712 Side Cover 15
- 6200002 Grease Fitting 7, 11, 15
- 6200090 Spring 21
- 6300018 Adapter 15
- 6300150 Adapter 15
- 6300405 Adapter 15
- 6300731 Adapter 15
- 6300878 Slewing Ring 15
- 6300901 Pinion 15
- 6300902 Valve Cross-port Relief 15
- 6302668 Adapter 23, 27
- 6302669 Adapter 23
- 6302670 Adapter 19, 23
- 6302672 Slewing Ring 13
- 6310149 Adapter 15
- 6310152 Adapter 15
- 6310379 Hydraulic Adapter 15
- 6310382 Adapter 15
- 6340015 Motor 15
- 6350176 Cylinder 11
- 6350177 Swivel Manifold 27
- 6360038 Flow Controls 15
- 6360153 Booster Valve 23
- 6370006 Hose Clamp 13
- Assembly Blade Kit 5, 8, 9
- Assembly Brokk Sub-Head 5, 12, 13
- Assembly Concrete Jaw 5, 16, 17
- Assembly Cylinder and Pins 5, 10, 11
- Assembly Frame and Access Covers 5, 24, 25
- Assembly Hoses and Cylinder Blocks 5, 18, 19
- Assembly Hydraulic Booster 5, 22, 23
- Assembly Pivot Group 5, 6, 7
- Assembly Rotation Brake 5, 20, 21
- Assembly Swivel Manifold 5, 26, 27
- Assembly Third-Member Sub-Head 14, 15
- Bolt Drive Specifications 34
- Bolt Torque Specifications 28, 32
- Contact Information 2, 39
- F0110020 Hex Head Capscrew M10 x 1.5 x 20 15
- F0112045 Hex Head Capscrew M12 x 1.75 x 45 27
- F0112050 Hex Head Bolt M12 x 1.75 x 50 9
- F0114070 Hex Head Capscrew M14 x 2 x 70 13, 15
- F0116035 Hex Head Capscrew M16 x 2 x 35 25
- F0263100 Hex Head Capscrew $\frac{5}{8}$ x 18 x 1 15
- F0412040 Flat Head Capscrew M12 x 1.75 x 40 9
- F0610020 Socket Head Capscrew M10 x 1.50 x 20 7
- F0612020 Socket Head Capscrew M12 x 1.75 x 20 23
- F0612030 Socket Head Capscrew M12 x 1.75 x 30 11, 13
- F0612060 Socket Head Capscrew M12 x 1.75 x 60 15
- F0614020 Socket Head Capscrew M14 x 2 x 20 23
- F0614030 Socket Head Capscrew M14 x 2 x 30 19
- F0616040 Socket Head Capscrew M16 x 2 x 40 7
- F0812175 Hex Nut M12 x 1.75 9
- F0824300 Hex Nut M24 x 3 21
- F1201021 Flat Washer M10 15
- F1201224 Flat Washer M12 9, 15
- F1201630 Flat Washer M16 25
- F1310058 Flat Washer Wide 15
- F1401200 Lock Washer M12 15
- F1900050 Nord Lock Washer M12 27
- F2524080 Set Screw M24 x 3 21
- General Arrangement 4, 5
- O-Ring Boss & Flat Face O-Ring Torque Specifications 33
- Parts Order Form 37
- Parts Order Policy and Procedure 36
- Procedures 30, 31
- S0190219 O-Ring 19
- Table of Contents 3
- Thread Treatment Diagram 29
- Warranty 35



GENESIS®

The Promise of Performance.

CONTACT INFORMATION

Genesis Attachments

1000 Genesis Drive
Superior, WI 54880 USA

Toll Free: 888-SHEAR-IT
(888-743-2748)

Phone: 715.395.5252

E-mail:
info@genesisattachments.com

Europe/Africa/Middle East Genesis GmbH

Teramostrasse 23
87700 Memmingen, Germany

Phone: +49 83 31 9 25 98 0

Fax: +49 83 31 9 25 98 80

genesis-europe.com

E-mail:
info@genesis-europe.com

Asia Pacific Representative Office

24 Upper Serangoon View #12-28
Singapore 534205

Phone: +65 9673 9730

E-mail:
tchoo@genesisattachments.com

Central America & Colombia

Cra 13A #89-38 / Ofi 613
Bogota, Colombia

Phone: +57 1 610 8160 / 795 8747

E-mail:
contact@themsagroup.com

View and download all manuals: genesisattachments.com/manuals
Patents: genesisattachments.com/products/patents